

# NTCIP 1202 Version 04

---

## National Transportation Communications for ITS Protocol Draft Concept of Operations (ConOps): Object Definitions for Actuated Signal Controllers (ASC) Interface

---

**Draft v04.01 May 1, 2023**

This is a draft document, which is distributed for review and comment purposes only. You may reproduce and distribute this document within your organization, but only for the purposes of and only to the extent necessary to facilitate review and comment to the NTCIP Coordinator.

Please ensure that all copies include this notice. This document contains preliminary information that is subject to change.

Published by

American Association of State Highway and Transportation Officials (AASHTO)  
444 North Capitol Street, N.W., Suite 249  
Washington, D.C. 20001

Institute of Transportation Engineers (ITE)  
1627 Eye Street, N.W., Suite 550  
Washington, D.C. 20006

National Electrical Manufacturers Association (NEMA)  
1300 North 17th Street, Suite 900  
Rosslyn, Virginia 22209-3801

### REVISION HISTORY

<b>Filename</b>	<b>Version</b>	<b>Date</b>	<b>Notes</b>
NTCIP 1202v04.01a.docx	04.01a	5/1/23	Chan – Submitted to ASC WG and USDOT. Final ConOps
NTCIP 1202v04.01.docx	04.01	4/27/23	Lahiri – Addresses ConOps Walkthrough comments
NTCIP 1202v04.00a.docx	04.00a	3/15/23	Chan – Submitted to ASC WG and USDOT. Initial Draft ConOps
NTCIP 1202v04.00.docx	04.00	3/11/23	Lahiri – Initial Draft

## NOTICES

### Copyright Notice

© 2023 by the American Association of State Highway and Transportation Officials (AASHTO), the Institute of Transportation Engineers (ITE), and the National Electrical Manufacturers Association (NEMA). All intellectual property rights, including, but not limited to, the rights of reproduction, translation, and display are reserved under the laws of the United States of America, the Universal Copyright Convention, the Berne Convention, and the International and Pan American Copyright Conventions. Except as licensed or permitted, you may not copy these materials without prior written permission from AASHTO, ITE, or NEMA. Use of these materials does not give you any rights of ownership or claim of copyright in or to these materials.

Visit [www.ntcip.org](http://www.ntcip.org) for other copyright information, for instructions to request reprints of excerpts, and to request reproduction that is not granted below.

### PDF File License Agreement

To the extent that these materials are distributed by AASHTO / ITE / NEMA in the form of an Adobe® Portable Document Format (PDF) electronic data file (the "PDF file"), AASHTO / ITE / NEMA authorizes each registered PDF file user to view, download, copy, or print the PDF file available from the authorized Web site, subject to the terms and conditions of this license agreement:

- a) you may download one copy of each PDF file for personal, noncommercial, and intraorganizational use only;
- b) ownership of the PDF file is not transferred to you; you are licensed to use the PDF file;
- c) you may make one more electronic copy of the PDF file, such as to a second hard drive or burn to a CD;
- d) you agree not to copy, distribute, or transfer the PDF file from that media to any other electronic media or device;
- e) you may print one paper copy of the PDF file;
- f) you may make one paper reproduction of the printed copy;
- g) any permitted copies of the PDF file must retain the copyright notice, and any other proprietary notices contained in the file;
- h) the PDF file license does not include (1) resale of the PDF file or copies, (2) republishing the content in compendiums or anthologies, (3) publishing excerpts in commercial publications or works for hire, (4) editing or modification of the PDF file except those portions as permitted, (5) posting on network servers or distribution by electronic mail or from electronic storage devices, and (6) translation to other languages or conversion to other electronic formats;
- i) other use of the PDF file and printed copy requires express, prior written consent.

### Data Dictionary and MIB Distribution Permission

To the extent that these materials are distributed by AASHTO / ITE / NEMA in the form of a Data Dictionary ("DD") or Management Information Base ("MIB"), AASHTO / ITE / NEMA extend the following permission:

You may make or distribute unlimited copies, including derivative works, of the DD or MIB, including copies for commercial distribution, provided that:

- a) each copy you make or distribute includes the citation "Derived from NTCIP 0000 [insert the standard number]. Copyright by AASHTO / ITE / NEMA. Used by permission.";

- b) the copies or derivative works are not made part of the standard publications or works offered by other standard developing organizations or publishers or as works-for-hire not associated with commercial hardware or software products intended for field implementation;
- c) use of the DD or MIB is restricted in that the SYNTAX fields may only be modified to define: 1) a more restrictive subrange; or 2) a subset of the standard enumerated values; or 3) a set of retired and defined enumerated values for systems supporting multiversion interoperability;
- d) the description field may be modified but only to the extent that: 1) the more restrictive subrange is defined; and 2) only those bit values or enumerated values that are supported are listed.  
[from 8002 A2 v04]

These materials are delivered "AS IS" without any warranties as to their use or performance.

**AASHTO / ITE / NEMA and their suppliers do not warrant the performance or results you may obtain by using these materials. AASHTO / ITE / NEMA and their suppliers make no warranties, express or implied, as to noninfringement of third party rights, merchantability, or fitness for any particular purpose. In no event will AASHTO / ITE / NEMA or their suppliers be liable to you or any third party for any claim or for any consequential, incidental or special damages, including any lost profits or lost savings, arising from your reproduction or use of these materials, even if an AASHTO / ITE / NEMA representative has been advised of the possibility of such damages.**

Some states or jurisdictions do not allow the exclusion or limitation of incidental, consequential, or special damages, or the exclusion of implied warranties, so the above limitations may not apply to a given user.

Use of these materials does not constitute an endorsement or affiliation by or between AASHTO, ITE, or NEMA and the user, the user's company, or the products and services of the user's company.

If the user is unwilling to accept the foregoing restrictions, he or she should immediately return these materials.

### **PRL and RTM Distribution Permission**

To the extent that these materials are distributed by AASHTO / ITE / NEMA in the form of a Protocol Requirements List ("PRL") or a Requirements Traceability Matrix ("RTM"), AASHTO / ITE / NEMA extend the following permission:

- a) you may make or distribute unlimited copies, including derivative works of the PRL (then known as a Profile Implementation Conformance Statement ("PICS")) or the RTM, provided that each copy you make or distribute contains the citation "Based on NTCIP 0000 [insert the standard number] PRL or RTM. Used by permission. Original text © AASHTO / ITE / NEMA.";
- b) you may only modify the PRL or the RTM by adding: 1) text in the Project Requirements column, which is the only column that may be modified to show a product's implementation or the project-specific requirements; and/or 2) additional table columns or table rows that are clearly labeled as ADDITIONAL for project-unique or vendor-unique features; and
- c) if the PRL or RTM excerpt is made from an unapproved draft, add to the citation "PRL (or RTM) excerpted from a draft standard containing preliminary information that is subject to change."

This limited permission does not include reuse in works offered by other standards developing organizations or publishers, and does not include reuse in works-for-hire, compendiums, or electronic storage devices that are not associated with procurement documents, or commercial hardware, or commercial software products intended for field installation.

A PRL is completed to indicate the features that are supported in an implementation. Visit [www.ntcip.org](http://www.ntcip.org) for information on electronic copies of the MIBs, PRLs, and RTMs.

## **TRF Distribution Permission**

A Testing Requirements Form ("TRF") may be a Testing Requirements Traceability Table and/or Test Procedures. To the extent that these materials are distributed by AASHTO / ITE / NEMA in the form of a TRF, AASHTO / ITE / NEMA extend the following permission:

- a) you may make and/or distribute unlimited electronic or hard copies, including derivative works of the TRF, provided that each copy you make and/or distribute contains the citation "Based on NTCIP 0000 [insert the standard number] TRF. Used by permission. Original text © AASHTO / ITE / NEMA.";
- b) you may not modify the logical flow of any test procedure, without clearly noting and marking any such modification; and
- c) if the TRF excerpt is made from an unapproved draft, add to the citation "TRF excerpted from a draft standard containing preliminary information that is subject to change."

## **Content and Liability Disclaimer**

The information in this publication was considered technically sound by the consensus of persons engaged in the development and approval of the document at the time it was developed. Consensus does not necessarily mean that there is unanimous agreement among every person participating in the development of this document.

AASHTO, ITE, and NEMA standards and guideline publications, of which the document contained herein is one, are developed through a voluntary consensus standards development process. This process brings together volunteers and seeks out the views of persons who have an interest in the topic covered by this publication. While AASHTO, ITE, and NEMA administer the process and establish rules to promote fairness in the development of consensus, they do not write the document and they do not independently test, evaluate, or verify the accuracy or completeness of any information or the soundness of any judgments contained in their standards and guideline publications.

AASHTO, ITE, and NEMA disclaim liability for any personal injury, property, or other damages of any nature whatsoever, whether special, indirect, consequential, or compensatory, directly or indirectly resulting from the publication, use of, application, or reliance on this document. AASHTO, ITE, and NEMA disclaim and make no guaranty or warranty, express or implied, as to the accuracy or completeness of any information published herein, and disclaims and makes no warranty that the information in this document will fulfill any of your particular purposes or needs. AASHTO, ITE, and NEMA do not undertake to guarantee the performance of any individual manufacturer or seller's products or services by virtue of this standard or guide.

In publishing and making this document available, AASHTO, ITE, and NEMA are not undertaking to render professional or other services for or on behalf of any person or entity, nor are AASHTO, ITE, and NEMA undertaking to perform any duty owed by any person or entity to someone else. Anyone using this document should rely on his or her own independent judgment or, as appropriate, seek the advice of a competent professional in determining the exercise of reasonable care in any given circumstances. Information and other standards on the topic covered by this publication may be available from other sources, which the user may wish to consult for additional views or information not covered by this publication.

AASHTO, ITE, and NEMA have no power, nor do they undertake to police or enforce compliance with the contents of this document. AASHTO, ITE, and NEMA do not certify, test, or inspect products, designs, or installations for safety or health purposes. Any certification or other statement of compliance with any health or safety-related information in this document shall not be attributable to AASHTO, ITE, or NEMA and is solely the responsibility of the certifier or maker of the statement.

## Acknowledgements

NTCIP 1202 v04 was prepared by the NTCIP Actuated Signal Controller Working Group (ASC WG), which is a subdivision of the Joint Committee on the NTCIP. The NTCIP Joint Committee is organized under a Memorandum of Understanding among the American Association of State Highway and Transportation Officials (AASHTO), the Institute of Transportation Engineers (ITE), and the National Electrical Manufacturers Association (NEMA). The NTCIP Joint Committee consists of six representatives from each of the standards organizations, and provides guidance for NTCIP development.

When NTCIP 1202 v03 was prepared, the following individuals were voting (indicated by an asterisk) or alternate voting members of the NTCIP ASC WG:

- City of Anaheim, John Thai\* (Co-Chair)
- California Department of Transportation, Mike Robinson\*, Jay Schultz
- Econolite Control Products, Inc., Dustin DeVoe\*, Dan Brandesky
- Florida Department of Transportation, Matthew DeWitt\*, Jeffrey Morgan, Derek Vollmer
- Minnesota Department of Transportation, Ray Starr\*, Terry Haukom, Peter Skweres
- Nissan Motor Co., Roy Goudy\*
- Oregon Department of Transportation, Christopher Primm\*
- Pillar Consulting, Ralph Boaz\*
- Q-Free, Doug Tarico\* (Co-Chair), Douglas Crawford
- Texas A&M University (TTI), Kevin Balke\*, Hassan Charara, Srinivasa Sunkari
- TransCore ITS, Robert Rausch\*, Keith Patton
- Yunex Traffic, Jonathan Grant\*, Dave Miller, Iouri Nemirovski

Observing members include:

- Caliper Corporation, Wuping Xin
- Consensus Systems Technologies, Patrick Chan, Manny Insignares, AJ Lahiri
- Florida DOT, Ronald Meyer
- Kapsch, Joerg 'Nu' Rosenbohm
- Michigan DOT, Bashir Choudry
- Noblis, Justin Anderson, Mike Mercer
- Oregon Department of Transportation, Roger Boettcher
- Oriux, Ray Deer, Joe Socci
- Parsons Transportation Group, Jon Wyatt, Dmitri Khijniak
- SWARCO McCain Inc., Mark Simpson
- Trevilon Corp., Kenneth Vaughn
- Utah DOT, Mike Blanchette

Additional stakeholders who provided input or monitored development include:

- CAMP, Jay Parikh
- Cubic, Shaun Alford
- City of Toronto, Rakesh Patel
- DKS & Associates, Alan Clelland
- Global Traffic Technologies, LLC, Christian Kulus
- Gresham Smith, James Anderson
- GreenFactor, Canny Quach
- Intsignia, Craig Hidders
- Iteris, Frank Provenzano
- KLD, Satya Muthuswamy
- Maricopa County DOT, April Wire
- Miovision, Greg Barlow
- Mixon Hill, Christopher Poe, Jackson Holderman
- OmniAir, Randy Roebuck
- SANDAG, Peter Thompson
- Seattle DOT, Michael Mullen
- Skyline Technology Solution, Israel Lopez
- UTA, Taylor Li
- WSP, Eric Gionet

In addition to the many volunteer efforts, recognition is also given to those organizations that supported the effort by providing funding:

- U.S. Department of Transportation

## Foreword

NTCIP 1202 v04, an NTCIP standards publication, identifies and defines how a management station may wish to interface with a field device to control and monitor traffic signal controllers and associated detectors in an NTCIP-conformant fashion. NTCIP 1202 v04 may also identify and define how a traffic signal controller NTCIP 1202 v04 uses only metric units.

NTCIP 1202 v04 is titled Actuated Signal Controllers (ASC) Interface Protocol to express the multiple sections and annexes that are included in NTCIP 1202 v04. This NTCIP 1200-series standards publication has grown beyond the "object definitions" that were reflected in the title for its predecessors, NTCIP 1202 versions v01 (1996), v02 (2005), v03 (2018).

NTCIP 1202 v04 defines data elements for use with Actuated Signal Controller Units. The data is defined using the Simple Network Management Protocol (SNMP) object-type format as defined in RFC 1212 and the defined NTCIP format defined in NTCIP 8004. This data would typically be exchanged using one of the NTCIP 1103 recognized Application Layers (e.g., SNMP). Previous versions of NTCIP 1202 used SNMPv1. NTCIP 1202 v04 uses SNMPv3 and does not support SNMPv1.

NTCIP 1202 v04 follows an established systems engineering approach to support procurement processes. The PRL is designed to allow an agency to indicate what user needs are applicable to a procurement, and to select which requirements are to be implemented in a project specific implementation. Proper completion of the PRL by the agency results in a specification that is more likely to satisfy the agency's project needs and that is conformant to NTCIP 1202 v04. The RTM defines the interface specifications for those requirements selected, and can be used to develop the test plans and test procedures.

The following keywords apply to this document: AASHTO, ITE, NEMA, NTCIP, ASC, data, data dictionary, object, MIB, PRL and RTM.

NTCIP 1202 v04 includes a number of normative and informative annexes.

NTCIP 1202 v04 is also an NTCIP Data Dictionary standard. Data Dictionary standards provide definitions of data concepts (messages, data frames, and data elements) for use within NTCIP systems; and are approved by AASHTO, ITE, and NEMA through a ballot process, after a recommendation by the NTCIP Joint Committee. For more information about NTCIP standards, or to acquire the related NTCIP 1202 v04 MIB, visit [www.ntcip.org](http://www.ntcip.org).

## User Comment Instructions

The term "User Comment" includes any type of written inquiry, comment, question, or proposed revision, from an individual person or organization, about any NTCIP 1202 v04 content. A "Request for Interpretation" is also classified as a User Comment. User Comments are solicited at any time. In preparation of this NTCIP standards publication, input of users and other interested parties was sought and evaluated.

User Comments are generally referred to the committee responsible for developing and/or maintaining NTCIP 1202 v04. The committee chairperson, or their designee, may contact the submitter for clarification of the User Comment. When the committee chairperson or designee reports the committee's consensus opinion related to the User Comment, that opinion is forwarded to the submitter. The committee chairperson may report that action on the User Comment may be deferred to a future committee meeting and/or a future revision of the standards publication. Previous User Comments and their disposition may be available for reference and information at [www.ntcip.org](http://www.ntcip.org).

A User Comment should be submitted to this address:

NTCIP Coordinator  
National Electrical Manufacturers Association  
1300 North 17th Street, Suite 900  
Rosslyn, Virginia 22209-3801  
e-mail: [ntcip@nema.org](mailto:ntcip@nema.org)

A User Comment should be submitted in the following form:

Standard Publication number and version:  
Page:  
Section, Paragraph, or Clause:  
Comment:  
Editorial or Substantive?:  
Suggested Alternative Language:

Please include your name, organization, and address in your correspondence.

### **Approvals**

To be completed prior to publication.

### **History**

In 1992, the NEMA 3TS Transportation Management Systems and Associated Control Devices Section began the effort to develop NTCIP. Under the guidance of the Federal Highway Administration's NTCIP Steering Group, the NEMA effort was expanded to include the development of communications standards for all transportation field devices that could be used in an ITS network.

In September 1996, an agreement was executed among AASHTO, ITE, and NEMA to jointly develop, approve, and maintain the NTCIP standards. In late 1998, the Actuated Signal Controller Working Group was tasked with the effort to update the Actuated Traffic Signal Controller Object Definitions document. The first meeting of this working group was held in October 1999. From 1996 to 1999, this document was referenced as NEMA TS 3.5-1996. However, to provide an organized numbering scheme for the NTCIP documents, this document is now referenced as NTCIP 1202. As included in the following development history, NTCIP 1202 has experienced revisions over time:

NEMA TS 3.5-1996. 1996 – Approved by NEMA. 1996 – Accepted as a Recommended Standard by the Joint Committee on the NTCIP. 1997 – Approved by AASHTO and ITE.  
v01.07a printed with NEMA cover.

NTCIP 1202 v01. v01.07b printed with joint cover. v01.07c printed to PDF in November 2002.  
v01.07d printed to PDF for no-cost distribution January 2005.

NTCIP 1202 Amendment 1. November 1999 – Accepted as a User Comment Draft Amendment by the Joint Committee on the NTCIP. April 2000 – NTCIP Standards Bulletin B0049 sent NTCIP 1202 Amendment 1 v01.06b for user comment. NTCIP 1202 Amendment 1, a User Comment Draft, was incorporated into 1202v02, and was not advanced further.

NTCIP 1202 v02.10. June 2001 – Accepted as a User Comment Draft by the Joint Committee on the NTCIP. February 2002 – NTCIP Standards Bulletin B0068 referred v02.13 for user review and comment.



NTCIP 1202 v02.16. October 2002 – Accepted as a Recommended Standard by the Joint Committee on the NTCIP. April 2004 – NTCIP Standards Bulletin B0091 referred v02.18 for balloting. Approved by AASHTO in November 2004, approved by ITE in March 2005, and approved by NEMA in November 2004.

NTCIP 1202:2005 v02.19. November 2005 – Edited document for publication. By the terms of MOU on CTPA article 1.2, the ownership of version 02 was assigned to AASHTO, ITE, and NEMA because the preexisting work was revised by more than 50%.

NTCIP 1202 v03 was developed to reflect lessons learned, to update the document to the new documentation formats, and to add new features such as support for a connected vehicle interface. NTCIP 1202 v03 also follows an established systems engineering approach. Several new sections were added to relate user needs identified in a concept of operations, functional requirements, interface specifications and a requirements traceability matrix to the existing sections.

As NTCIP 1202 v03 was about to be published and distributed, a user provided proposed clarifications/corrections associated with experience in implementing the Flashing Yellow Arrow (FYA) functionality. The clarifications/corrections constitute the FYA errata, and is published as NTCIP 1202 v03A in May 2019.

The NTCIP 1202 v03B Amendment was published in May 2023 to address an urgent need to fix errors, clarify definitions, and provide additional guidance for traffic signal controllers to support the SAE J2735 SPaT Message in response to guidance detailed in Connected Transportation Interoperability (CTI) 4501, Connected Intersections (CI) Implementation Guide.

NTCIP 1202 v04 to be published in 2024.

## Compatibility of Versions

To distinguish NTCIP 1202 v04 (as published) from previous drafts, NTCIP 1202 v04 also includes NTCIP 1202 v04.00a on each page header. All NTCIP Standards Publications have a major and minor version number for configuration management. The version number SYNTAX is "v00.00a," with the major version number before the period, and the minor version number and edition letter (if any) after the period.

The MIB associated with NTCIP 1202 v04 (as published) is **tbd**.

NTCIP 1202 v04 is designated, and should be cited as, NTCIP 1202 v04. Anyone using NTCIP 1202 v04 should seek information about the version number that is of interest to them in any given circumstance. The PRL, RTM and the MIB should all reference the version number of the standards publication that was the source of the excerpted material.

Note: Users of the Test Procedure Generator (TPG) should enter Standard Number 1202, Major Version Number 04, Minor Version Number 0, and browse for the TPG-enabled version of NTCIP 1202 v04.

Compliant systems based on later, or higher, version numbers MAY NOT be compatible with compliant systems based on earlier, or lower, version numbers. Anyone using NTCIP 1202 v04 should also consult NTCIP **8004 v02** for specific guidelines on compatibility.

## CONTENTS

Note: The following Contents listing includes seven heading levels (for annexes) to permit TPG evaluation.

<This page is intentionally left blank.>

## Section 1 General [Informative]

### 1.1 Scope

NTCIP 1202 v04 specifies the logical interface between an Actuated Signal Controller (ASC) and the host systems that control them; and the logical interface between an ASC and other roadside devices or processes at the intersection, such as a signal monitoring unit (SMU) in the transportation cabinet, or a connected vehicle (CV) roadside process (such as inside a roadside unit (RSU)). NTCIP 1202 v04 describes the supported ASC functionality in terms of user needs and requirements; however, the nature of the interfaces is determined in part by the operational nature of the devices being controlled, and therefore NTCIP 1202 v04 touches on such operational issues on occasion.

Prior to the development of NTCIP 1202, there were no standards defining how ASCs communicate with host systems or roadside devices/processes. As a result, each manufacturer has developed its own protocol to meet its own particular needs. This approach has resulted in systems that are not interchangeable or interoperable. If an agency wishes to use either a central management system or additional ASC from a different vendor, the agency encounters significant systems integration challenges, requiring additional resources to address. These additional resource requirements inhibit information sharing within and between various potential users of the data and prevent vendor independence. Without manufacturer independence, resource requirements further increase because of a lack of a competitive market.

These problems have not been limited to traffic signal controllers. Many other devices also need to exchange information. In surface transportation, examples include dynamic message signs, bus priority sensors, weather, and environmental monitoring, etc.

To address these problems, NTCIP is developing a family of open standards for communications between field devices and central management systems. NTCIP 1202 v04 is part of that larger family and is designed to define an interoperable and interchangeable interface between a transportation management system and an ASC, while still allowing for extensions beyond NTCIP 1202 v04 to allow for new functions as needed; and between an ASC and other roadside devices/processes. This approach is expected to support the deployment of ASC from one or more vendors in a consistent and resource-efficient way.

NTCIP 1202 v04 standardizes the communications interface by identifying the various operational needs of the users (Section 2) and subsequently identifying the necessary requirements (Section 3) that support each need. NTCIP standardized communications interface used to fulfill these requirements are identified by dialogs (Section 4) and related data concepts (Section 5) that support each requirement. Traceability among the various sections is defined by the Protocol Requirements List (Section 3.3) and the Requirements Traceability Matrix (Annex A). Conformance requirements for NTCIP 1202 v04 are provided in Section 3.3. NTCIP 1202 v04 only addresses a subset of the requirements needed for procurement. It does not address requirements related to the performance of the traffic detectors (e.g., accuracy, the supported detection range, the time it takes to detect conditions, etc.), hardware components, mounting details, etc.

Previous versions of NTCIP 1202 addressed only ASCs that employ vehicle or pedestrian detectors to activate a particular phase – the scope did not include pre-timed, or fixed-time signal controllers that cycle through phases regardless of the number of vehicles or pedestrians present. ASCs included both fully actuated traffic signals, where all phases are actuated, and phases are skipped if no vehicles or pedestrians are detected; and semi-actuated traffic signals, where at least one phase is guaranteed to be served regardless of whether pedestrians or vehicles are detected. For the NTCIP 1202 purposes,

controllers that allow different phases to be active (or skipped) at any point in time phase are known as phase-based controllers.

Beginning with NTCIP 1202 v03, the scope was expanded to standardize the communications interface between an ASC and a CV Roadside Process, which may be located inside an RSU. An RSU is any connected vehicle field device that is used to broadcast messages to, and receive messages from, nearby vehicles using Vehicle-to-Everything (V2X) communications. V2X communications includes Dedicated Short-Range Communications (DSRC), and Cellular Vehicle-To-Everything (C-V2X).

An implementation of NTCIP 1202 requires lower-level services to structure, encode, and exchange the data concepts defined by NTCIP 1202. NTCIP 1202 assumes that the data concepts are exchanged by one of the protocols defined in NTCIP 2301.

## 1.2 References

### 1.2.1 Normative References

Normative references contain provisions that, through reference in this text, constitute provisions of NTCIP 1202 v04. Other references in NTCIP 1202 v04 might provide a complete understanding or provide additional information. At the time of publication, the editions indicated were valid. All standards are subject to revision, and parties to agreements based on NTCIP 1202 v04 are encouraged to investigate the possibility of applying the most recent editions of the standards listed.

Identifier	Title
ATC 5301 v02	Advanced Transportation Controller (ATC) Cabinet Standard Version 02, v02.02, AASHTO / ITE / NEMA, published March 18, 2019
NEMA TS 1-1989 (R2020)	NEMA Standards Publication TS 1-1989 (R1994, R2000, R2005, R2020), Traffic Control Systems (Not Recommended for New Designs)
NEMA TS 2-2021	NEMA Standards Publication TS 2-2021, Traffic Controller Assemblies with NTCIP Requirements Version 03.08, NEMA, published 2021.
SAE J2735	V2X Communications Message Set Dictionary, SAE International, published November 2022

### 1.2.2 Other References

The following documents and standards may provide the reader with a better understanding of the entire protocol and the relations between all parts of the protocol. However, these documents do not contain direct provisions that are required by NTCIP 1202 v04. At the time of publication, the editions indicated were valid. All standards are subject to revision, and parties to agreements based on NTCIP 1202 v04 are encouraged to investigate the possibility of applying the most recent editions of the standard listed.

Identifier	Title
ATC 5201 API v06	Advanced Transportation Controller (ATC) Standard Version v06A, v06A.37, AASHTO / ITE / NEMA, published July 29, 2020
ATC 5401 v02b	Application Programming Interface (API) Standard for the Advanced Transportation Controller (ATC) v02B, v02B.45, published February 16, 2023
CTI 4001	Connected Transportation Interoperability 4001 - Roadside Unit (RSU) Standard, September 2022, v01.01. <a href="https://www.ite.org/technical-resources/standards/rsu-standardization/">https://www.ite.org/technical-resources/standards/rsu-standardization/</a>
CTI 4501	Connected Transportation Interoperability 4501 – Connected Intersections (CI) Implementation Guide, June 2022, v01.01. <a href="https://www.ite.org/technical-resources/standards/connected-intersections/">https://www.ite.org/technical-resources/standards/connected-intersections/</a>
Caltrans TEES 2020	Caltrans Transportation Electrical Equipment Specifications (TEES), 2020

Identifier	Title
IEEE Std 100-2000	The Authoritative Dictionary of IEEE Standards Terms
Manual of Uniform Traffic Control Devices	Manual of Uniform Traffic Control Devices, FHWA, May 2012
Multimodal Intelligent Traffic Signal System	Multi-Modal Intelligent Traffic Signal System – Phase II: System Development, Deployment and Field Test, Final Report, Connected Vehicle Pooled Fund Study, September 2016. <a href="https://engineering.virginia.edu/sites/default/files/common/Centers/CTS/CVPFS/projects/53%20MMITSS%20Phase%20-%20Final%20Report%20-%20FINAL%2009252016-compressed.pdf">https://engineering.virginia.edu/sites/default/files/common/Centers/CTS/CVPFS/projects/53 MMITSS Phase 2 - Final Report – FINAL 09252016-compressed.pdf</a>
Preemption of Traffic Signals Near RR Grade Crossings, 2006	The Preemption of Traffic Signals Near RR Grade Crossings, an ITE Recommended Practice, Institute of Transportation Engineers, 2006. (Note: 2021 edition still applicable?)
U.S. Architecture Reference for Cooperative and Intelligent Transportation (ARC-IT)	Architecture Reference for Cooperative and Intelligent Transportation (ARC-IT), USDOT, <a href="http://arc-it.net/">http://arc-it.net/</a>
V2I Hub Interface Control Document	Integrated Vehicle-to-Infrastructure Prototype (IVP), V2I Hub Interface Control Document (ICD) - Final Report March 2017, FHWA JPO

### 1.2.3 Contact Information

#### 1.2.3.1 Architecture Reference for Cooperative and Intelligent Transportation

The Architecture Reference for Cooperative and Intelligent Transportation (ARC-IT) may be viewed at:

<http://arc-it.net/>

ARC-IT is also known as US National ITS Architecture and combines the US National ITS Architecture and the Connected Vehicle Reference Implementation Architecture (CVRIA).

#### 1.2.3.2 ATC Standards

The Advanced Transportation Controller (ATC) Family of Standards may be view at:

<https://www.ite.org/technical-resources/standards/>

#### 1.2.3.3 Caltrans Standards

Caltrans' Transportation Electrical Equipment Specifications (TEES) may be viewed at:

<https://dot.ca.gov/programs/traffic-operations/tees>

#### 1.2.3.4 Internet Documents

Obtain Request for Comment (RFC) electronic documents from several repositories on the World Wide Web, or by "anonymous" File Transfer Protocol (FTP) with several hosts. Browse or FTP to:

[www.rfc-editor.org](http://www.rfc-editor.org)  
[www.rfc-editor.org/repositories.html](http://www.rfc-editor.org/repositories.html)  
 for FTP sites, read [ftp://ftp.isi.edu/in-notes/rfc-retrieval.txt](http://ftp.isi.edu/in-notes/rfc-retrieval.txt)

### 1.2.3.5 NEMA Standards

Copies of NEMA standards may be obtained from:

National Electrical Manufacturers Association  
1300 N.17th Street, Suite 900  
Rosslyn, Virginia 22209-3801  
[www.nema.org](http://www.nema.org)

### 1.2.3.6 NTCIP Standards

Copies of NTCIP standards may be obtained from:

NTCIP Coordinator  
National Electrical Manufacturers Association  
1300 N.17th Street, Suite 900  
Rosslyn, Virginia 22209-3801  
[www.ntcip.org](http://www.ntcip.org)  
e-mail: [ntcip@nema.org](mailto:ntcip@nema.org)

Draft amendments, which are under discussion by the relevant NTCIP Working Group, and amendments recommended by the NTCIP Joint Committee are available.

### 1.2.3.7 SAE International Standards

Copies of SAE International standards may be obtained from:

SAE International  
400 Commonwealth Drive  
Warrendale, PA 15096  
[www.sae.org](http://www.sae.org)

## 1.3 General Statements

<In the opinion of the responsible NTCIP working group, Section 1.3 does not apply in the context of NTCIP 1202 v04.>

## 1.4 Terms

For the purposes of NTCIP 1202 v04, the following terms, definitions, acronyms, and abbreviations apply. Meteorological terms not defined in this section are in accordance with their definitions in the Glossary of Meteorology. Electrical and electronic terms not defined here are used in accordance with their definitions in IEEE Std 100-2000. English words not defined here or in IEEE Std 100-2000 are used in accordance with their definitions in Webster's New Collegiate Dictionary.

Term	Definition
<b>Actuated Signal Controller (ASC)</b>	Any traffic signal controller, regardless if it is a phase-based controller or interval-based controller.
<b>actuation</b>	The operation of any type of detector.
<b>advanced preemption time</b>	The period of time between the minimum warning time needed for railroad operations and the maximum preemption time required for highway traffic signal operations.

Term	Definition
<b>automatic flash</b>	Automatic programmed flash mode not caused by manual switch activation or fault condition or startup.
<b>auxiliary function</b>	A control that may activate auxiliary functions or outputs in an actuated controller unit.
<b>backup mode</b>	Control by local TBC or Interconnect based on absence of master or central command.
<b>barrier</b>	<p>A barrier (compatibility line) is a reference point in the preferred sequence of a multi-ring CU at which all rings are interlocked.</p> <p>Note: Barriers assure there is no concurrent selection and timing of conflicting phases for traffic movement in different rings. All rings cross the barrier simultaneously for the selection and timing of phases on the other side.</p>
<b>Basic Safety Message (BSM)</b>	<p>The Basic Safety Message (BSM) is used in a variety of applications to exchange safety data regarding vehicle state.</p> <p>Source: SAE J2735_202211</p>
<b>Bus Rapid Transit (BRT)</b>	Bus rapid transit (BRT) refers to a system of buses that operate more like a conventional rail system than the traditional local buses. BRT lines can operate in mixed traffic like other bus routes, in reserved bus lanes, or even in segregated rights of way. For the purpose of this document, BRT refers to reserved bus lanes or segregated lanes arriving at a signalized intersection.
<b>call</b>	A registration of a demand for right-of-way by traffic (vehicles or pedestrians) to a controller unit.
<b>call, serviceable conflicting</b>	<p>A call which:</p> <ol style="list-style-type: none"> <li>a) Occurs on a conflicting phase not having the right-of-way at the time the call is placed.</li> <li>b) Occurs on a conflicting phase which is capable of responding to a call.</li> <li>c) When occurring on a conflicting phase operating in an occupancy mode, remains present until given its right-of-way.</li> </ol>
<b>channel</b>	Three circuits of a Monitor Device wired to monitor the green, yellow, and red outputs of the associated load switch position in the Terminal & Facilities. Channel 1 is assumed to monitor Load Switch 1, etc.
<b>check</b>	An output from a controller unit that indicates the existence of unanswered call(s).
<b>clear track change interval</b>	The yellow change interval following the clear track green interval and preceding the railroad hold intervals. A red clearance interval shall follow the clear track change interval if such an interval follows the normal yellow change interval. (Preemption of Traffic Signals Near Railroad Crossings - ITE, 2006)
<b>computed lane</b>	A lane that has a similar geometry and attributes of another lane.



Term	Definition
<b>concurrency group</b>	<p>A group of phases which describes possible timing combinations.</p> <p>Note: A phase within the group is required to be able to time concurrently with any other phase from another ring contained in the group. For example, in the typical dual-ring eight phase design, phases 1, 2, 5, and 6 form one concurrency group, and phases 3, 4, 7, and 8 form another concurrency group.</p>
<b>concurrent timing</b>	<p>A mode of controller unit operation whereby a traffic phase can be selected and timed simultaneously and independently with another traffic phase.</p>
<b>connected device</b>	<p>A mobile device, such as a vehicle or smartphone, equipped to broadcast, transmit or receive messages using V2X communications.</p>
<b>Connected Vehicle Roadside Process</b>	<p>A logical, functional process consisting of sub-processes that support the connected vehicle environment. From the context of an ASC, the relevant sub-processes include running intersection CV applications, broadcasting the SPAT and MAP messages to connected devices, and processing Basic Safety Messages (BSMs) and Personal Safety Messages (PSMs) received from connected devices by the CV Roadside Process. Physically, this may be a roadside unit (RSU).</p>
<b>Controller Assembly (CA)</b>	<p>A complete electrical device mounted in a cabinet for controlling the operation of a traffic control signal display(s).</p>
<b>Controller Unit (CU)</b>	<p>A controller unit is that portion of a controller assembly that is devoted to the selection and timing of signal displays.</p>
<b>Coordinated Universal Time (UTC)</b>	<p>UTC is the time standard commonly used across the world. The world's timing centers have agreed to keep their time scales closely synchronized – or coordinated. This 24-hour time standard is kept using highly precise atomic clocks combined with the Earth's rotation. UTC is similar to Greenwich Mean Time, but while UTC is a time standard, GMT refers to a time zone (similar to Eastern Standard Time). UTC never changes to account for daylight saving time.</p>
<b>coordination</b>	<p>The control of controller units in a manner to provide a relationship between specific green indications at adjacent intersections in accordance with a time schedule to permit continuous operation of groups of vehicles along the street at a planned speed.</p>
<b>coordinator</b>	<p>A device or program/routine which provides coordination.</p>
<b>cycle</b>	<p>The total time to complete one sequence of signalization around an intersection. In an actuated controller unit, a complete cycle is dependent on the presence of calls on all phases.</p> <p>Note: In a pre-timed controller unit it is a complete sequence of signal indications.</p>
<b>cycle length</b>	<p>The time period in seconds required for one complete cycle.</p>

Term	Definition
<b>Detector, pedestrian</b>	<p>Pedestrian detectors may be pushbuttons or passive detection devices. Passive detection devices register the presence of a pedestrian in a position indicative of a desire to cross, without requiring the pedestrian to push a button. Some passive detection devices are capable of tracking the progress of a pedestrian as the pedestrian crosses the roadway for the purpose of extending or shortening the duration of certain pedestrian timing intervals.</p> <p>Note: Manual of Uniform Traffic Control Devices, FHWA, May 2012</p>
<b>detector, system</b>	Any type of vehicle detector used to obtain representative traffic flow information.
<b>detector, vehicle</b>	A detector that is responsive to operation by or the presence of a vehicle.
<b>dial</b>	The cycle timing reference or coordination input activating same. Dial is also frequently used to describe the cycle.
<b>display map</b>	A graphic display of the street system being controlled showing the status of the signal indications and the status of the traffic flow conditions.
<b>dual entry</b>	<p>Dual entry is a mode of operation (in a multi-ring CU) in which one phase in each ring is required to be in service.</p> <p>Note: If a call does not exist in a ring when it crosses the barrier, a phase is selected in that ring to be activated by the CU in a predetermined manner.</p>
<b>dwell</b>	The interval portion of a phase when present timing requirements have been completed.
<b>dynamic timing pattern</b>	A transient timing plan to be used for the next cycle only.
<b>external control location application</b>	An application that asserts a higher-level control over the traffic signal controller.
<b>enabled lanes (list)</b>	A sequence of lane identifiers for lanes that are identified to be enabled (active) and can be used by the appropriate travelers at the current time.
<b>first coordinated phase</b>	The coordinated phase which occurs first within the concurrent group of phases containing the coordinated phase(s) when there are constant calls on all phases.
<b>Flash</b>	An operation where one section in each vehicle signal (yellow or red) is alternately on and off with a one second cycle time and a 50 percent duty cycle.
<b>fault monitor state</b>	<p>Internal CU diagnostics have determined that the CU device is not in a safe operational state.</p> <p>Note: An output may be asserted to indicate this condition.</p>

Term	Definition
<b>force off</b>	<p>A command to force the termination of the green indication in the actuated mode or Walk Hold in the nonactuated mode of the associated phase.</p> <p>Note: Termination is subject to the presence of a serviceable conflicting call. The Force Off function is not effective during the timing of the Initial, Walk, or Pedestrian Clearance. The Force Off is only effective as long as the condition is sustained. If a phase-specific Force Off is applied, the Force Off does not prevent the start of green for that phase.</p>
<b>Free</b>	Operation without coordination control from any source.
<b>gap reduction</b>	A feature whereby the Unit Extension or allowed time spacing between successive vehicle actuations on the phase displaying the green in the extensible portion of the Green indication is reduced.
<b>Group</b>	Any portion of a traffic control network (system) that can be controlled by a common set of timing patterns.
<b>Hold</b>	A command that retains the existing Green indication.
<b>Hold-on line</b>	A signal to an intersection controller commanding it to remain under computer control.
<b>interchangeability</b>	<p>A condition which exists when two or more items possess such functional and physical characteristics as to be equivalent in performance and durability and are capable of being exchanged one for the other without alteration of the items themselves, or adjoining items, except for adjustment, and without selection for fit and performance.</p> <p>Source: National Telecommunications and Information Administration, U.S. Department of Commerce</p>
<b>Interconnect</b>	A means of remotely controlling some or all of the functions of a traffic signal.
<b>interoperability</b>	<p>The ability of two or more systems or components to exchange information and use the information that has been exchanged</p> <p>Source: IEEE Std. 610.12-1990: IEEE Standard Glossary of Software Engineering Terminology</p>
<b>intersection status</b>	The knowledge of whether a controlled intersection is on-line and which mode it is currently operating in.
<b>indication</b>	The part or parts of the signal cycle during which signal indication displays do not change.
<b>Interval-based controller</b>	A traffic signal controller implementing a sequence of defined, discrete steps (i.e., an interval), each interval driving their associated signal indications, in a repeating cycle according to the timing constraints programmed into the device. Note that some step sequences may be displayed or skipped in response to traffic conditions.

Term	Definition
<b>Light Rail Transit (LRT)</b>	A metropolitan electric railway system characterized by its ability to operate single cars or short trains along exclusive rights-of-way at ground level, on aerial structures, in subways or, occasionally, in streets, and to board and discharge passengers at track or car-floor level. For the purpose of this document, LRT refers to exclusive rights-of-way lanes arriving at a signalized intersection.
<b>load switch driver group</b>	The set of three outputs which are used to drive load switch inputs to provide a Green, Yellow, or Red output condition for vehicle signals or Walk, Ped Clear, or Don't Walk output condition for pedestrian signals.
<b>Malfunction Management Unit (MMU)</b>	A device used to detect and respond to improper and conflicting signals and improper operating voltages in a traffic controller assembly.
<b>Management Information Base (MIB)</b>	A structured collection or database of related managed objects defined using Abstract Syntax Notation One (ASN.1).  Source: NTCIP 8004 v02 and ISO/IEC 8824-1:2008 and ISO/IEC 8825-1:2008.
<b>MAP message</b>	The MAPData message is used to convey many types of geographic road information. At the current time, its primary use is to convey one or more intersection lane geometry maps within a single message.  Source: SAE J2735_202211
<b>maximum green</b>	The maximum green time with a serviceable opposing actuation, which may start during the initial portion.
<b>Movement</b>	An action that is taken to traverse through an intersection, reflecting the user perspective and defined by the user type.
<b>Multi-ring controller unit</b>	A multi-ring CU contains two or more interlocked rings which are arranged to time in a preferred sequence and to allow concurrent timing of all rings, subject to barrier restraint.
<b>Node point</b>	A point defining the centerline of the pathway of a lane.
<b>nonlocking memory</b>	A mode of actuated-controller-unit operation which does not require the retention of a call for future utilization by the controller assembly.
<b>Occupancy</b>	A measurement of vehicle presence within a zone of detection, expressed in seconds of time a given point or area is occupied by a vehicle.
<b>Off-line</b>	A controller assembly not under the control of the normal control source.
<b>Offset</b>	The time relationship, expressed in seconds, between the starting point of the first coordinated phase Green and a system reference point. (See definition of First Coordinated Phase)
<b>omit, phase</b>	A command that causes omission of a selected phase.
<b>On-line</b>	A controller assembly under the control of the normal control source.

Term	Definition
<b>Overlap</b>	A Green display that allows traffic movement during the green indications of and clearance indications between two or more phases.
<b>Passage time</b>	The time allowed for a vehicle to travel at a selected speed from the detector to the stop line.
<b>Pattern</b>	<p>A unique set of coordination parameters (cycle value, split values, offset value, and either signal plan or phase sequence).</p> <p>Note: A phase-based timing pattern consists of a cycle length, offset, set of minimum green and maximum green values, force off (determined by splits in some cases), and phase sequence. It also includes specification of phase parameters for minimum or maximum vehicle recall, pedestrian recall, or phase omit.</p> <p>An interval-based timing pattern consists of a cycle length, offset, set of minimum and programmed interval duration values, and a signal plan sequence.</p>
<b>Pedestrian clearance interval</b>	The first clearance interval for the pedestrian signal following the pedestrian WALK indication.
<b>Pedestrian recycle</b>	A method of placing a recurring demand for pedestrian service on the movement when that movement is not in its Walk interval.
<b>permissive</b>	A time period, during which the CU is allowed to leave the coordinated phase(s) under coordination control to go to other phases.
<b>Personal Safety Message (PSM)</b>	<p>The Personal Safety Message (PSM) is used to broadcast safety data regarding the kinematic state of various types of Vulnerable Road Users (VRU), such as pedestrians, cyclists or road workers.</p> <p>Source: SAE J2735_202211</p>
<b>phase sequence</b>	A predetermined order in which the phases of a cycle occur.
<b>phase, active</b>	The indicated phase is currently timing. A phase is always active if it is Green or Yellow (Walk or Pedestrian Clear for Pedestrian Phases). It is also active if it is timing Red Clearance. It may be considered active during Red Dwell.
<b>phase, conflicting</b>	Conflicting phases are two or more traffic phases which cause interfering traffic movements if operated concurrently.
<b>phase, nonconflicting</b>	Nonconflicting phases are two or more traffic phases which do not cause interfering traffic movements if operated concurrently.
<b>phase, pedestrian</b>	A traffic phase allocated to pedestrian traffic which may provide a right-of-way pedestrian indication either concurrently with one or more vehicular phases, or to the exclusion of all vehicular phases.
<b>phase, traffic</b>	Those green, change and clearance intervals in a cycle assigned to any independent movement(s) of traffic.
<b>phase, vehicular</b>	A vehicular phase is a phase which is allocated to vehicular traffic movement as timed by the controller unit.

Term	Definition
<b>preempt dwell interval</b>	The period of time when the track area is occupied by a tracked vehicle.
<b>preemption</b>	The transfer of the normal control of signals to a special signal control mode for the purpose of servicing railroad crossings, emergency vehicle passage, mass transit vehicle passage, and other special tasks, the control of which require terminating normal traffic control to provide the priority needs of the special task.
<b>preemptor</b>	A device or program/routine which provides preemption.
<b>priority request</b>	The information that describes a need for (signal) priority service based upon user-defined criteria (such as the number of minutes behind schedule, vehicle occupancy levels, vehicle class, etc.).  Note: From NTCIP 1211 v02.
<b>progression</b>	The act of various controller units providing specific green indications in accordance with a time schedule to permit continuous operation of groups of vehicles along the street at a planned speed.
<b>red clearance interval</b>	A clearance interval which may follow the yellow change interval during which both the terminating phase and the next phase display Red signal indications.
<b>red revert</b>	Provision within the controller unit to assure a minimum Red signal indication in a phase following the Yellow Change interval of that phase.
<b>referenced lane</b>	A lane used to define the attributes of another lane.
<b>rest</b>	The interval portion of a phase when present timing requirements have been completed.
<b>right-of-way transfer time</b>	While providing preemption, the maximum amount of time needed for the worst-case condition, prior to display of the clear track green interval. This includes any railroad or traffic signal control equipment time to react to a preemption call, and any traffic signal green, pedestrian walk and clearance, yellow change and red clearance interval for conflicting traffic.
<b>ring</b>	A ring consists of two or more sequentially timed and individually selected conflicting phases so arranged as to occur in an established order.
<b>Roadside Unit (RSU)</b>	A transportation infrastructure communications device located on the roadside that provides V2X connectivity between OBUs/MUs and other parts of the transportation infrastructure including traffic control devices, traffic management systems, and back-office systems. Note: Devices that are not part of the transportation infrastructure, such as cellular base stations or satellites, are not RSUs. Source: CTI 4001
<b>sample</b>	A collection of data recorded over an identified period of time.
<b>sequence, interval</b>	The order of appearance of signal indications during successive intervals of a cycle.

Term	Definition
<b>service request</b>	<p>The information that describes a (signal) priority service to be processed by the ASC.</p> <p>Note: From NTCIP 1211 v02</p>
<b>service requestor</b>	<p>A traveler requesting signal service or priority using a connected device. The connected device may be an OBE or a smartphone.</p>
<b>signal control priority strategy</b>	<p>Defines the phases to be serviced, phases to be omitted, and the maximum green times that can be reduced or extended to service a priority request.</p>
<b>Signal Monitoring Unit (SMU)</b>	<p>A subassembly that performs signal monitoring functions within a transportation cabinet. The signal monitoring unit is called a Malfunction Management Unit (MMU) in the NEMA TS 2 Standard and a Cabinet Monitor Unit (CMU) in the ATC Cabinet Standard.</p>
<b>signal plan</b>	<p>A unique set of parameters that define the phase / interval sequence of signal indications and control for one cycle.</p>
<b>signal request</b>	<p>A request for signal service or signal priority via an SAE J2735 Signal Request Message.</p>
<b>single entry</b>	<p>Single entry is a mode of operation (in a multi-ring CU) in which a phase in one ring can be selected and timed alone if there is no demand for service in a nonconflicting phase on the parallel ring(s).</p>
<b>single-ring controller unit</b>	<p>A single-ring CU contains two or more sequentially timed and individually selected conflicting phases so arranged as to occur in an established order.</p>
<b>special function</b>	<p>A control that may activate a device external to the controller unit.</p>
<b>split</b>	<p>The segment of the cycle length allocated to each phase or interval that may occur (expressed in seconds).</p> <p>Note: In an actuated controller unit, split is the time in the cycle allocated to a phase.</p>
<b>standby mode</b>	<p>An operational state called by master or central command which directs the controller unit to select Pattern, Automatic Flash, or Automatic Free based on local Time Base schedule or Interconnect inputs.</p>
<b>stall condition</b>	<p>An operational state in which the ASC can no longer transmit any data to the management station.</p> <p>Note: The health monitor (watchdog) might or might not work in this situation, but its condition is not able to be transmitted to the management station.</p>
<b>TimeChangeDetail</b>	<p>A data frame that conveys details about the timing of a phase within a movement. The core data concept expressed is the time stamp (time mark) at which the related phase will change to the next state.</p> <p>Source: SAE J2735_202211</p>
<b>Time-based Control (TBC)</b>	<p>A means for the automatic selection of modes of operation of traffic signals in a manner prescribed by a predetermined time schedule.</p>

Term	Definition
<b>timing pattern</b>	See "Pattern"
<b>timing plan</b>	The Split times for all segments (Phase/Interval) of the coordination cycle.
<b>track clearing interval</b>	While providing preemption, the time assigned to clear stopped vehicles from the track area on the approach to the signalized highway intersection.
<b>Traffic Signal Controller Broadcast Message (TSCBM)</b>	A message defined in the V2I Hub Interface Control Document containing signal phase and timing (SPaT) information comprised of the SNMP data objects sent by the traffic signal controller to an RSU.
<b>volume</b>	The number of vehicles passing a given point per unit of time.
<b>yellow change interval</b>	The first interval following the green interval in which the signal indication for that phase is yellow.
<b>yield</b>	A command which permits termination of the green interval.
<b>zone</b>	An area in which traffic parameters can be measured and/or traffic data can be generated.

### 1.5 Abbreviations

The abbreviations (acronyms) used in NTCIP 1202 v04, and not defined in Section 1.4 are defined as follows:

<b>APS</b>	Accessible Pedestrian Signals
<b>CMU</b>	Cabinet Monitor Unit
<b>CV</b>	Connected Vehicles
<b>CVRIA</b>	Connected Vehicles Reference Implementation Architecture
<b>DSRC</b>	Dedicated Short Range Communications
<b>ECLA</b>	External Control Local Application
<b>HOV</b>	High Occupancy Vehicle
<b>ITS</b>	Intelligent Transportation Systems
<b>MU</b>	Mobile Unit
<b>OBU</b>	On-Board Unit
<b>PRL</b>	Protocol Requirements List
<b>RSE</b>	Roadside Equipment
<b>RSU</b>	Roadside Unit
<b>RTM</b>	Requirements Traceability Matrix
<b>SIU</b>	Serial Interface Unit
<b>SNMP</b>	Simple Network Management Protocol
<b>SPaT</b>	Signal Phase and Timing (as defined by SAE J2735_202007)



<b>V2X</b>	Vehicle-To-Everything
<b>VRU</b>	Vulnerable Road User

## **Section 2**

### **Concept of Operations [Normative]**

Section 2 defines the user needs that subsequent sections within NTCIP 1202 v04 address. Accepted system engineering processes detail that requirements should only be developed to fulfill well-defined user needs. The first stage in this process is to identify the ways in which the system is intended to be used. In the case of NTCIP 1202 v04, this entails identifying the various ways in which transportation system managers may use ASC information to fulfill their duties.

This concept of operations provides the reader with:

- a) a detailed description of the scope of NTCIP 1202 v04;
- b) an explanation of how an ASC is expected to fit into the larger context of an ITS network;
- c) a starting point in the agency procurement process; and
- d) an understanding of the perspective of the designers of NTCIP 1202 v04.

Section 2 is intended for all readers of NTCIP 1202 v04, including:

- a) transportation system managers
- b) transportation operations personnel
- c) transportation engineers
- d) system integrators
- e) device manufacturers

For the first three categories of readers, Section 2 is useful to understand how ASC equipment can be used in their system. For this audience, Section 2 serves as the starting point in the procurement process, and enables these readers to become familiar with each feature supported by NTCIP 1202 v04 and determine whether that feature is appropriate for their implementation. If it is, then the procurement specification needs to require support for the feature and all of the mandatory requirements related to that feature.

For the last two categories of readers, Section 2 provides a more thorough understanding as to why the more detailed requirements exist later in NTCIP 1202 v04.

#### **2.1 Tutorial [Informative]**

A concept of operations describes a proposed system from the users' perspective. Typically, a concept of operations is used on a project to ensure that system developers understand users' needs. Within the context of NTCIP standards, a concept of operations documents the intent of each feature for which NTCIP 1202 v04 supports a communications interface. It also serves as the starting point for users to select which features may be appropriate for their project.

The concept of operations starts with a discussion of the current situation and issues that have led to the need to deploy systems covered by the scope of NTCIP 1202 v04 and to the development of NTCIP 1202 v04 itself. This discussion is presented in layman's terms such that both the potential users of the system and the system developers can understand and appreciate the situation.

The concept of operations then documents key aspects about the proposed system, including:

- a) **Reference Physical Architecture.** The reference physical architecture defines the overall context of the proposed system and defines which specific interfaces are addressed by NTCIP 1202 v04. The reference physical architecture is supplemented with one or more samples that describe how the reference physical architecture may be realized in an actual deployment.
- b) **Architectural Needs.** The architectural needs section discusses the issues and needs relative to the system architecture that have a direct impact on NTCIP 1202 v04.
- c) **Features.** The features identify and describe the various functions that users may want components of an ASC system to perform. These features are derived from the high-level user needs identified in the problem statement but are refined and organized into a more manageable structure that forms the basis of the traceability tables contained in Section 3 and Annex A.

The architectural needs and features are collectively called user needs. Section 3 uses these user needs in the analysis of the system to define the various functional requirements of an ASC. Each user need shall be traced to one or more functional requirements, and each functional requirement shall be derived from at least one user need. This traceability is shown in the Protocol Requirements List (PRL) as provided in Section 3.3.

While NTCIP 1202 v04 is intended to standardize communications across a wide range of deployments, it is not intended to mandate support for every feature for every deployment. Therefore, the PRL also defines each user need and requirement as mandatory, optional, or conditional. The only items marked mandatory are those that relate to the most basic functionality of the device. To procure a device that meets specific needs, the user first identifies which optional needs are necessary for the specific project.

Each requirement identified is then presented in the Requirements Traceability Matrix (RTM) in Annex A, which defines how the requirement is fulfilled through standardized dialogs and data element definitions provided in Sections 4 and 5.

A conformant device may support other user needs, as long as they are conformant with the requirements of NTCIP 1202 v04 and its normative references (see Section 1.2.1). For example, a device may support data that has not been defined by NTCIP 1202 v04; however, when exchanged via one of the NTCIP 2301 v02 protocols, the data shall be properly registered with a valid OBJECT IDENTIFIER under the Global ISO Naming Tree.

Note: Off-the-shelf interoperability and interchangeability can only be obtained by using well-documented user needs, along with their corresponding requirements and design, that are broadly supported by the industry as a whole. Designing a system that uses environments or features not defined in a standard or not typically deployed in combination with one another inhibits the goals of interoperability and interchangeability, especially if the documentation of these user needs is not available for distribution to system integrators. NTCIP 1202 v04 allows implementations to support additional user needs to support innovation, which is constantly needed within the industry, but users should be aware of the risks involved with using such environments or features.

The concept of operations concludes by describing the degree to which security issues have been addressed by the NTCIP 1202 v04 and by providing a description of how NTCIP 1202 v04 relates to the Architecture Reference for Cooperative and Intelligent Transportation (ARC-IT), formerly known as the U.S. National ITS Architecture.

## 2.2 Current Situation and Problem Statement [Informative]

Transportation system managers use ASCs to control traffic operations on a roadway. ASCs allow different conflicting movements to travel across a roadway in a safe, orderly manner. In a roadway network, ASCs can be coordinated to improve mobility of certain movements, such as along a major arterial. Implemented correctly, ASCs can reduce:

- a) the number and severity of accidents
- b) delays
- c) stops
- d) fuel consumption
- e) emission of pollutants

There are numerous factors that may affect the operation of an ASC on a roadway. Transportation system managers need to program each ASC to avoid conflicting movements. Conflicting movements are not confined to one specific mode of travel. Travel modes that have movements controllable by an ASC include:

- a) Vehicles
- b) Pedestrians
- c) Bicycles
- d) Special vehicles

Special vehicles are vehicles that have one or more characteristics so that an ASC may treat differently than "ordinary" vehicles. Special vehicles may include emergency vehicles or transit vehicles that request preferential (i.e., priority) treatment, or a high occupancy vehicle (HOV) with its own right-of-way (e.g., an HOV-only lane) through the intersection.

Each travel mode may have its own minimum clearance requirements that are satisfied to provide sufficient time for traffic to traverse the roadway before a conflicting movement is allowed to move.

Transportation system managers can also program an ASC to use inputs from other devices, such as detectors, to measure demand for a specific movement to improve mobility, so that additional time is provided for the movement where the demand exists and less time, if any, is provided for the movement where demand does not exist. An ASC also may be deployed with signal preemption or signal priority capabilities to properly manage movements in special situations. These capabilities, if implemented by the transportation system manager, may allow an emergency vehicle responding to an incident or a railroad at a railroad crossing to preempt the signal and obtain right-of-way. Similarly, signal priority may allow a transit or other fleet vehicle to request preferential treatment through a signalized intersection.

The ASC is also expected to have an important role in the connected vehicle environment. In the United States, the connected vehicle environment has three major goals, to improve safety, mobility and the environment. Many of the key applications being developed in support of these goals near signalized intersections involve the infrastructure providing signal phasing and timing information to "connected" devices, such as connected vehicles and "connected" mobile devices, such as a smartphone.

### **2.3 Reference Physical Architecture [Informative]**

Section 2.3 represents an overview of what a complete ASC system may look like for a transportation agency, and identifies the specific information exchange paths to be addressed by NTCIP 1202 and related standards.

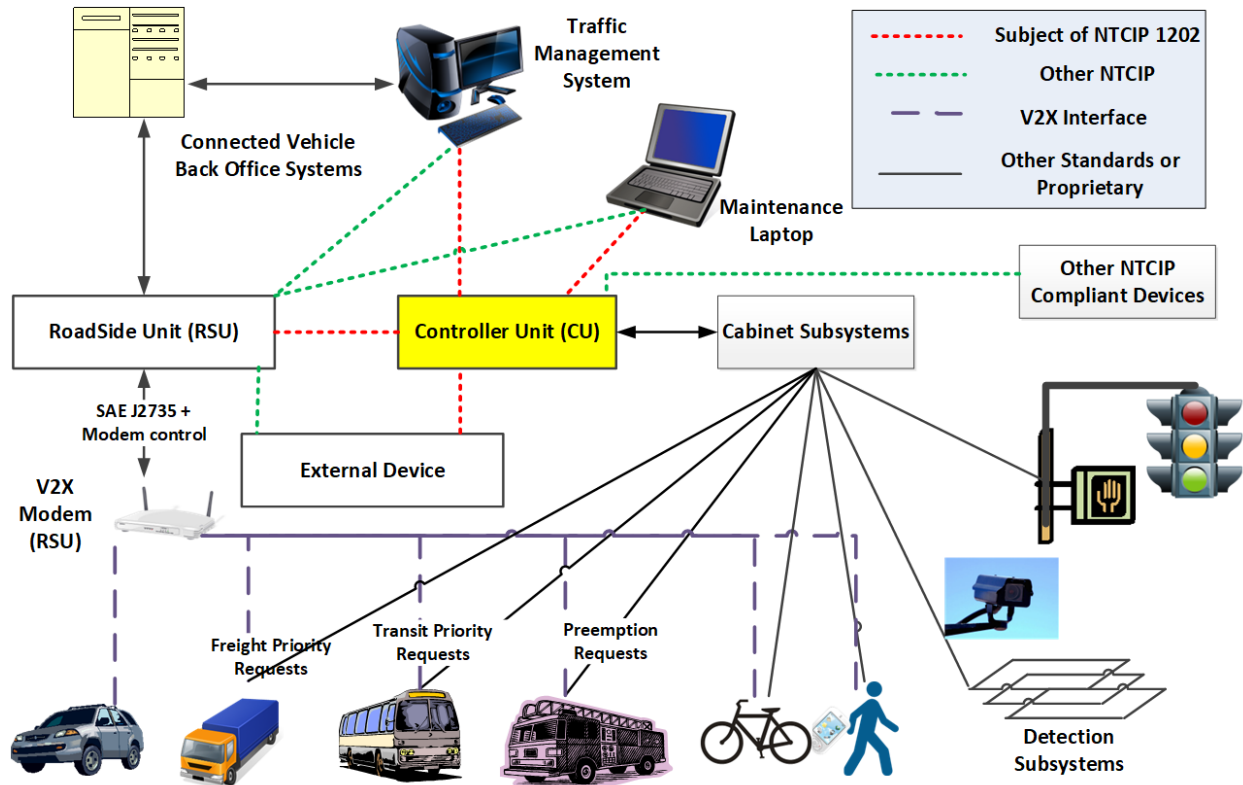

Figure 1 Reference Physical Architecture - ASC System

The physical components of the ASC system include:

- a) **Controller Unit (CU).** A host computing platform that is used to manage the traffic signals at an intersection. The CU is responsible for ensuring that the proper signal indications are present on traffic signals. It communicates with the Traffic Management System and other devices through communication ports, and interfaces with the cabinet subsystems to energize the signal heads, read vehicle actuations, drive other auxiliary outputs, and read various inputs such as pedestrian push buttons. It may also communicate with other roadside devices, including other CUs.
- b) **Traffic Management System.** A management station typically located in some type of management center (e.g., a Traffic Management Center (TMC)) and may be a considerable distance from the ASC. A management station is one or more host computing platforms that manage one or more NTCIP field devices, such as an ASC. The management station is responsible for configuring, monitoring, and controlling the ASC. There may be multiple management stations for a given ASC. A "manager" is a transportation system manager or maintenance person who needs to access information in the ASC through the management station.
- c) **Maintenance Laptop.** A computer that a field technician may use on a trip to visit the ASC or a field processor that may be used to access the ASC. The maintenance laptop typically acts as a management station, which is a host computing platform that manage one or more NTCIP field devices, such as an ASC. The management station is used to monitor the data reported from the ASC and can command the ASC under certain conditions. The maintenance laptop typically plugs directly into the CU. A "manager" is a transportation system manager or maintenance person who needs to access information in the ASC through the management station.
- d) **Roadside Unit (RSU).** A connected vehicle field device that includes a computing platform running applications and that supports secure communications with connected devices. The RSU receives messages from and transmits messages to nearby connected devices (such as vehicles via on-board units (OBUs) or mobile units (MUs) carried by vulnerable road users (VRUs) such as

pedestrians, bicyclist, or road workers) using V2X communications. In an ASC System, it may also act as a functional process, called the CV Roadside Process in NTCIP 1202.

- e) **Detection Subsystems.** The units that provide inputs for traffic-actuated control, surveillance, or data collection systems. Detection subsystems include a wide variety of devices to detect the presence and other characteristics of travelers within the range of the intersection. In some instances, such detection devices may be connected directly to the CU and collect a variety of data such as volume, occupancy, speed, and headway or used for signal priority or preempt detection.
- f) **External Device.** A physical device (equipment) that may be mounted inside the controller assembly to provide inputs to the CU, to control traffic flow, or use the outputs from the CU for other applications. Examples of external devices include traffic preemptors, signal priority equipment, accessible pedestrian signals, traffic control beacons, the V2X Hub and the MMITSS (Multimodal Intelligent Traffic Signal System) processor.
- g) **Cabinet Subsystems.** The controller assembly that consists of the electrical devices in the cabinet for controlling the operation of a traffic control signal display(s). See Figure 2.

Other components shown in Figure 1 include:

- h) **Connected Vehicle Back Office Systems.** Represent centers that manage and support the connected vehicle environment.
- i) **Other NTCIP Compliant Devices.** Another controller unit that the CU communicates with for coordination of traffic signals. The Other Controller Unit generally controls an adjacent traffic signal.

Note: The deployment of connected vehicle equipment (such as the RSU) is currently very limited, but is expected to be widespread as more V2X equipped vehicles are delivered to the marketplace. Also, Figure 1 is only one possible architecture that might be used for the deployment of the infrastructure for connected vehicles, and other architectures are possible.

### 2.3.1 ASC Characteristics – Cabinet Specifications

NTCIP 1202 v04 is intended to address the communications interface between any management station and a CU. However, some features defined within NTCIP 1202 v04 apply only to ASCs using a specific transportation cabinet architecture. There are five transportation cabinet architectures that are commonly used in North America.

- a) **Model 332 Cabinet.** A cabinet specification defined in the Caltrans Transportation Electrical Equipment Specification (TEES).
- b) **NEMA TS 1 Cabinet.** A cabinet architecture defined in NEMA TS 1.
- c) **NEMA TS 2 Type 2 Cabinet.** A cabinet architecture defined in NEMA TS 2.
- d) **NEMA TS 2 Type 1 Cabinet.** A cabinet architecture defined in NEMA TS 2.
- e) **ATC Cabinet.** A cabinet architecture defined in ATC 5301. Previously called the ITS Cabinet.

Figure 2 shows a more detailed look at the components that may be inside a cabinet subsystem.

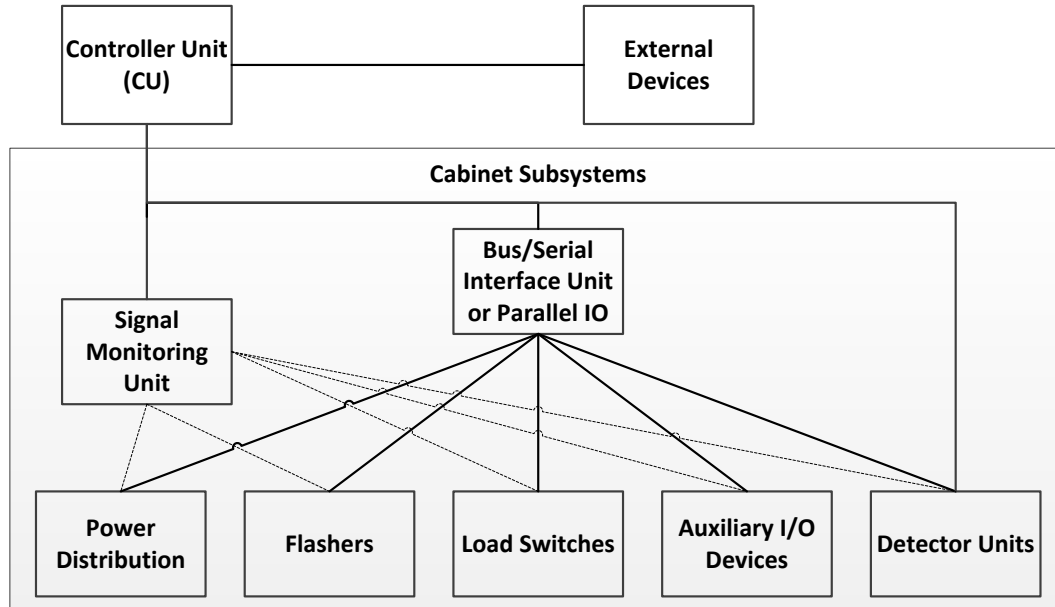

**Figure 2 Controller Assembly**

Cabinet subsystems include:

- a) **Bus/Serial Interface Unit or Parallel IO.** The communications interface between the CU and the cabinet subsystem. It is called the Bus Interface Unit in the NEMA TS 2 Standard and the Serial Interface Unit (SIU) in the ATC Cabinet Standard. Some systems may use a Parallel Input/Output (IO) for the communications interface. It provides the means by which the CU can control the various cabinet devices, and can monitor inputs to provide analysis and data for use by the traffic management algorithms and the Traffic Management System shown in Figure 1.
- b) **Power Distribution.** Provides protected power distribution to the various components and devices within the cabinet.
- c) **Flashers.** Devices used to open and close signal circuits at a repetitive rate. It is typically used to provide a "fail-safe" flashing operation when the Signal Monitoring Unit determines that there is a failure within the cabinet wiring/devices such as shorted load switches, defective cabinet power supplies, or conflicting signal indications.
- d) **Load Switches.** Devices used to switch power to the signal lamps/indications. This typically includes pedestrian signals, traffic signals, auxiliary signs, and other auxiliary devices.
- e) **Signal Monitoring Unit (SMU).** A subassembly that performs signal monitoring functions within a transportation cabinet. The signal monitoring unit is called a Malfunction Management Unit (MMU) in the NEMA TS 2 Standard and a Cabinet Monitor Unit (CMU) in the ATC Cabinet Standard. When it detects a failure in the operation or a device, it can place the cabinet into the flashing condition using the flashers. It also monitors the power line voltage and places the cabinet into the "fail safe" condition when the operating voltage is below configured minimums and holds the cabinet in the "startup" flashing condition upon power restoration to allow the CU to boot and start normal operation.
- f) **Detector Units.** Devices which support the detection of travelers (e.g., vehicles, pedestrians, bicycles, transit vehicles, emergency vehicles). In some cases, the interface allows the CU to monitor the health and gather additional information from the detection subsystems.

### 2.3.2 ASC Characteristics – Controller Types

Some features defined within NTCIP 1202 v04 may not be applicable to all ASCs - some features are dependent on whether an ASC is one of the following types of controllers.

- a) **Phase-based controller.** Phase-based signal controllers refers to a device implementing non-conflicting signal indications in response to traffic conditions and the timing constraints programmed into the device. A phase controls signal indications for one or more non-conflicting traffic movements and may be actuated by those movement's traffic. In a phase-based, fully actuated system, phases without traffic present may be skipped. Green indication durations may vary between pre-set minimum and maximum values, depending on detected traffic and programmed timing information.
- b) **Interval-based controller.** Interval-based signal controllers refers to a device implementing a sequence of defined, discrete steps (i.e., an interval), each driving the signal indications, in a repeating cycle according to the timing constraints programmed into the device. Note that some step sequences may be displayed or skipped in response to traffic conditions.
- c) **Stage-based controller.** Stage-based signal controller refers to a device implementing groups of different sequences of defined, discrete steps (i.e., an interval), each driving the signal indications in a repeated cycle. Groups of intervals may be skipped depending on traffic conditions.

Note: Some controllers can operate either as an interval-based controller or a phase-based controller (but not simultaneously). An agency (procurement) specification may include one or both of these types.

Only phase-based controllers are supported by NTCIP 1202 v04.

### 2.3.3 ASC Characteristics – Connected Vehicle Interface

NTCIP 1202 v04 also addresses the communications data exchange between an ASC and a CV Roadside Process. It is through this communications interface with the CV Roadside Process that an ASC primarily interacts with the connected vehicle environment. Before the ASC - CV Roadside Process interface can be effectively addressed, an understanding of the other interfaces between the RSU and connected devices, and the interface among the management station, an ASC and an RSU, is helpful.

Some features defined within NTCIP 1202 v04 for the connected vehicle interface are dependent on the relationship between the ASC and the RSU. The National ITS Architecture, known as the Architecture Reference for Cooperative and Intelligent Transportation (ARC-IT), implies a logical framework of applications and services that are allocated to the RSU. These applications may have needs for information that are provided by the ASC (e.g., information needed to create signal phase and timing (SPaT) messages, status of signal priority requests) or may provide information to the ASC so the ASC may improve safety and mobility at a signalized intersection (e.g., forward a signal priority request, forward location of connected vehicle).

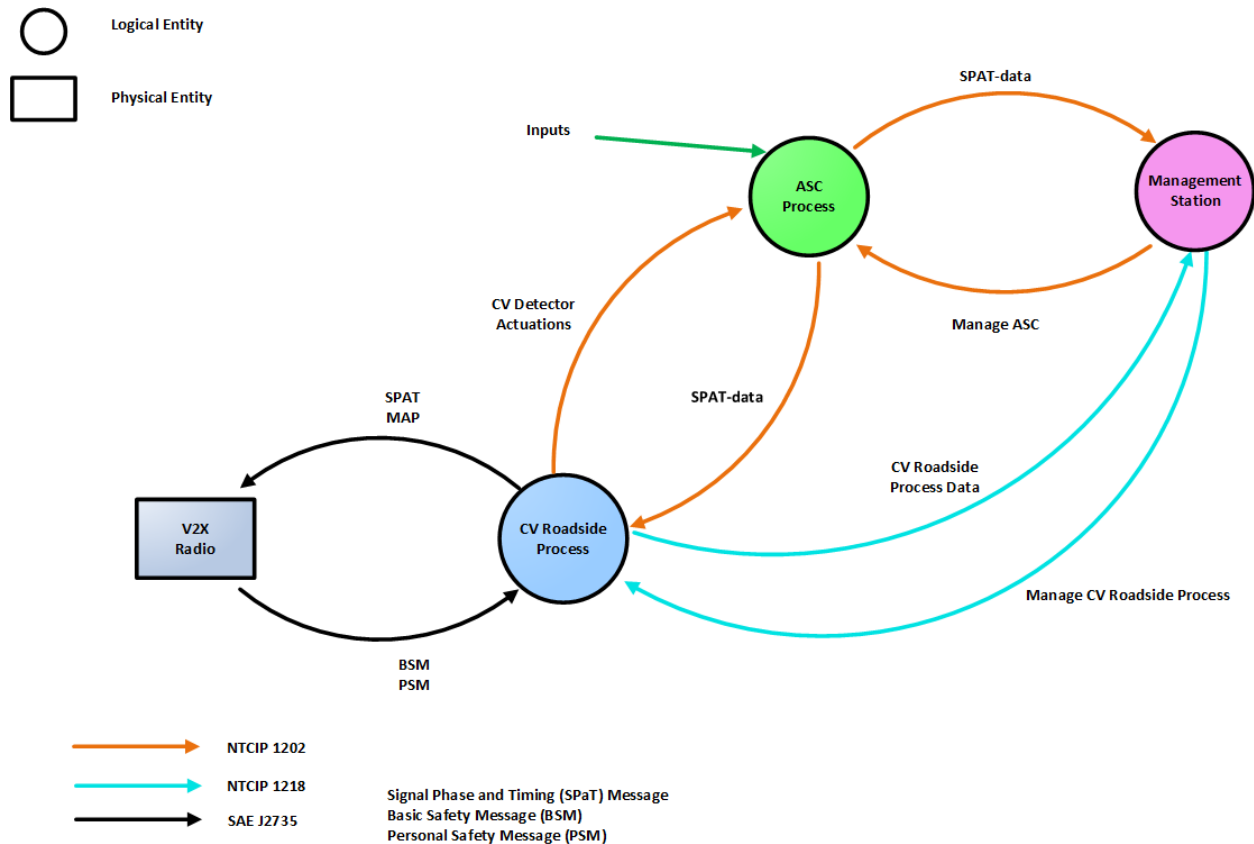

**Figure 3 ASC - Connected Vehicle System Context Diagram**

Figure 3 is a logical system context diagram for an ASC system's interaction with the connected vehicle environment. The connected vehicle environment around the ASC focuses on two distinct logical processes: the ASC Process and the Connected Vehicle (CV) Roadside Process.

The ASC Process consists of the traditional processes providing control of a signalized intersection, possibly using inputs that indicate the traffic demand around the intersection. The source of those inputs may be detection subsystems located within or connected to the same cabinet as the traffic signal controller, or from the CV Roadside Process. The ASC Process allows a management station, such as a traffic management system, to monitor and manage the traffic signal controller; and generates signal phase and timing information that may be shared with the CV Roadside Process.

The CV Roadside Process consists of sub-processes that support the connected vehicle environment. From the context of an ASC, the relevant sub-processes include running intersection CV applications, broadcasting the SPAT and MAP messages to connected devices, and processing Basic Safety Messages (BSMs) and Personal Safety Messages (PSMs) received from connected devices by the CV Roadside Process. In the context of an ASC, the CV Roadside Process is also responsible for receiving signal phase and timing information from the ASC Process. The CV Roadside Process may also allow a management station (traffic management system) to configure and manage the MAP messages that are broadcasted by the CV Roadside Process, and to configure the CV Roadside Process to use BSMs and PSMs as inputs to the ASC Process. The CV Roadside Process may also allow a management station to monitor the MAP messages broadcasted. The CV Roadside Process may also perform other functions, such as send and manage security certificates or to configure and manage other CV-related applications, however, these functions are outside the scope of NTCIP 1202 v04.



Figure 3 also depicts the interfaces between the different entities and processes that comprise the connected vehicle environment around the ASC. The information exchanges depicted in black, specifically between the V2X Radio and the CV Roadside Process, are expected to be in SAE J2735 format. The information exchanges in orange, specifically between the ASC Process and the CV Roadside Process and between the ASC Process and the management station, are expected to conform to the NTCIP family of standards and are addressed by NTCIP 1202 v04. The information in cyan between the CV Roadside Process and the management station allow a traffic management system to configure the RSU and are addressed by NTCIP 1218.

From a physical point of view, three possible physical architectures are considered in NTCIP 1202 v04, defined by where the CV Roadside Process is physically located.

In the first architecture, depicted in Figure 4, the CV Roadside Process is located in the RSU, which is a field-hardened computing device nearby, or within the same or a separate cabinet as the ASC. The V2X Radio depicted in Figure 4 may be a separate (standalone) physical device or integrated with physical RSU device.

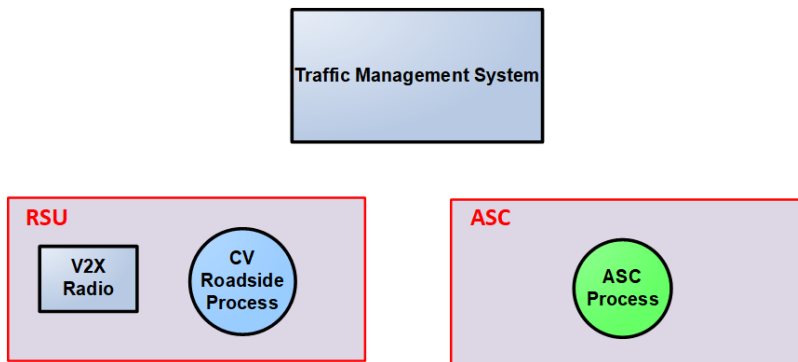

**Figure 4 Physical Architecture 1**

In a second physical architecture, depicted in Figure 5, has the CV Roadside Process and ASC Process in the same physical device, such as an ASC. The CV Roadside Process might be located in a separate processor mounted on a card within the controller assembly.

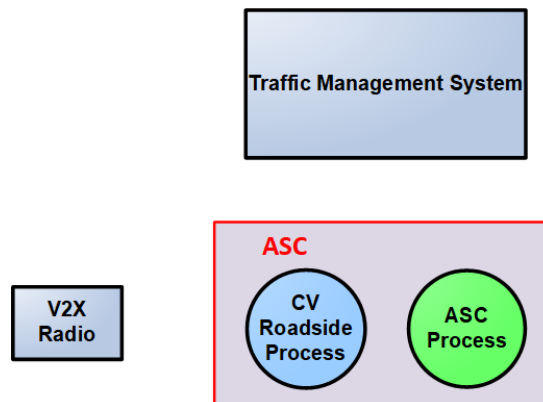

**Figure 5 Physical Architecture 2**

A third physical architecture, depicted in Figure 6, has some functions of the CV Roadside Process in an external device and the remaining functions, such as attaching security certificates, in the RSU. The external device, physically located between the ASC and the RSU, may reformat signal timing information from the ASC to a format that can be used by the RSU for broadcast to OBUs/MUs. Examples of an external device include MMITSS (Multimodal Intelligent Traffic Signal System) processor and the V2X Hub.

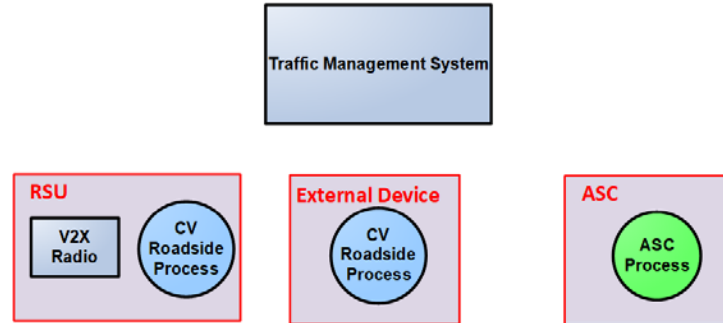

Figure 6 Physical Architecture 3

### 2.3.4 ASC Characteristics – Interface with Other Roadside Devices/Processes

NTCIP 1202 v04 also addresses the communications data exchange between an ASC and other roadside devices or processes that may exist within the Reference Physical Architecture (Figure 1) or within the controller assembly (Figure 2). The roadside devices or processes considered by NTCIP 1202 v04 include the logical interface with:

- a) **SMU.** A physical device to monitor the operations and devices in the controller assembly. The SMU is called a Malfunction Management Unit (MMU) in the NEMA TS 2 Standard and a Cabinet Monitor Unit (CMU) in the ATC Cabinet Standard. The SMU may inform the ASC when failures in controller assembly are detected, when the cabinet is in a "fail safe" condition (i.e., flashing), or when operating voltages are below configured minimums.
- b) **External Device.** A physical device, defined above in Section 2.3.
- c) **External Control Local Application (ECLA).** A logical entity that adjusts the signal timing in effect to accommodate different traffic patterns in real-time. An example of an ECLA is a traffic adaptive algorithm application external to the ASC, but asserting a higher-level control over the ASC. The ECLA may also be physically located in an external device or at a traffic management center.

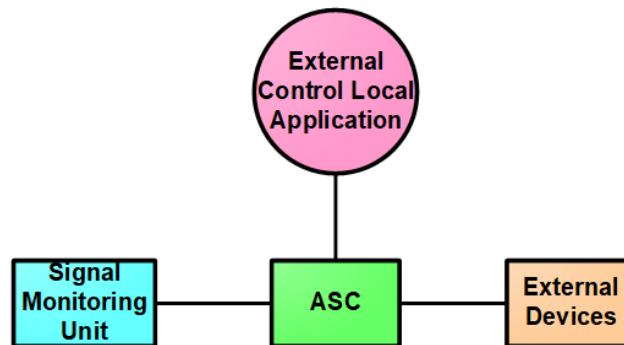

Figure 7 Roadside Process/Devices Interface

## 2.4 Architectural Needs

NTCIP 1202 v04 addresses the interface between an ASC and one or more management stations (e.g., central computers, laptops, RSUs, peer controller units, etc.). A management station needs to monitor the status of the ASC, manage the database in the ASC, and control the ASC. The management station also needs to retrieve data that has been collected by the ASC. After the management station has retrieved the data of interest, a manager can use the retrieved data to make decisions and initiate other events (such as changes to the ASC timing pattern) to better manage the transportation system.

NTCIP 1202 v04 also addresses the interface between an ASC with other roadside devices and processes, such as the CV Roadside Process. The CV Roadside Process needs data from the ASC

about current and future signal phasing and timing information, so the CV Roadside Process can forward this information to connected devices. For the interfaces between an ASC and a roadside device/process, the ASC may act as a management station, and the other device/process acts as an agent/server.

To enable communications between these components, the transportation system manager needs to establish a communication system that links the ASC with a management station. For some systems, the resources required for communications may be minimal and as such the system may be designed for constant polling; other systems may require significant resources for communicating with the ASC and as such the system may be designed to minimize data exchanges. When deploying an ASC, the system designer needs to consider which of the following operational environments need to be supported.

An ASC is expected to operate in the communications environment defined as follows.

#### **2.4.1 Provide Live Data**

The typical operational environment allows a management station to monitor and control the ASC by issuing requests (e.g., requests to access information, alter information, or control the device). In this environment, the ASC responds to requests from the management station (e.g., through the provision of live data, success/failure notice of information alteration, or success/failure of the command). This environment may also be used to allow an ASC to monitor another roadside process or device by issuing requests (e.g., request to access information).

#### **2.4.2 Provide Pre-Defined Data Blocks**

Some operational environments have limited data capacity due to limitations in the data rates of the media and/or due to multiple entities or devices sharing the same communications channel. In such environments, a transportation manager needs to exchange sets of data together so that data can be transmitted more efficiently over telecommunications networks, thereby conserving the limited data capacity of the channel. This capability reduces the upload and download times of data between a management station and an ASC, or an ASC with another device (e.g., CV Roadside Process). The sets of data may be standardized, pre-defined blocks of data or run-time definable sequences addressing functional areas associated with ASCs.

#### **2.4.3 Provide for Log Data Local Storage and Retrieval**

In a typical operational environment, the ASC needs to provide logged data to the management station for diagnostic purposes, and for operational environments (e.g., dial-up links) that do not have always-on connections. For example, logged data may include the time when the cabinet door is opened. The event log needs to be cleared either in a last-in last-out basis or by the management station because of limited storage space in the ASC.

#### **2.4.4 Provide for Database Management**

Traffic signal controllers are safety critical devices to manage the traffic movements for vehicles, pedestrians, bicycles, transit, and others are intersecting roadways (or railroad crossings). To ensure that the data downloaded from a central system software to an ASC makes logical sense, consistency checks on the downloaded need to be performed by the ASC. The user needs to therefore be able to manage the database by being able to open the database to write data, ensure that the downloaded data was received, command the ASC to perform a verification / consistency check the downloaded data, and to close the database to make the downloaded data available to the operational aspects of the ASC. Additionally, should there be any errors, the user needs to be able to determine the source of the error within the downloaded data.

## 2.4.5 Condition-based Exception Reporting

In some operational environments, it may be desirable to have the ASC automatically transmit data to the management station when certain conditions occur. Under this scenario, a manager can program the information to be automatically reported to the management station when a specified condition occurs. An example is a manager wants to know when a cabinet door is opened, when the ASC goes to an error flash condition, or when a phase becomes active; these conditions can be programmed to cause the transmission of the alarm objects thus providing the management station with information regarding the change of state at the transportation cabinet.

## 2.5 Features

Section 2.5 identifies and describes the various features that may be offered by the ASC. It is divided into the following:

- a) Manage the ASC Configuration
- b) Manage Signal Operations
- c) Manage Detectors
- d) Manage Connected Vehicles Interface
- e) Backwards Compatibility Features

### 2.5.1 Manage the ASC Configuration

This section identifies and describes the various features related to managing the configuration of the ASC. It consists of the following features:

- a) Retrieve Device Identity
- b) Manage Communications
- c) Monitor Cabinet Environment
- d) Monitor Power
- e) Retrieve Operational Performance Data
- f) Manage Auxiliary External Inputs/Outputs
- g) Manage Database
- h) Manage Peer-to-Peer with Other Devices
- i) Manage Signal Monitoring Unit Information
- j) Manage Interface with External Detectors

#### 2.5.1.1 Retrieve Device Identity

A manager needs to manage basic information about the ASC. This information consists of its location (latitude and longitude), and the make, model, and version of the device components. The device components can be a hardware, software, or firmware component, and could be a physical or logical entity in nature. This feature allows a manager to verify the identity of the ASC in the field and what software or firmware version is installed. This feature also allows a manager to retrieve a unique identifier of the device as provided by the device manufacturer.

#### 2.5.1.2 Manage Communications

A manager needs to manage each communications port in the ASC. This feature consists of enabling or disabling the communications ports, and configuring or retrieving the port address (e.g., IP address). This feature allows a manager to disable an unused communications port for security purposes or to reconfigure the ASC for a new communications media.

### **2.5.1.3 Manage Cabinet Environment**

A manager needs to monitor the transportation cabinet operating environment. This feature allows a manager to monitor for unsafe operating environments for the ASC so proper precautions can be taken. Unsafe operating environment consists of an open transportation cabinet door, high cabinet temperatures, or an indication that the cabinet fan has turned on.

### **2.5.1.4 Monitor Power**

A manager needs to monitor the power for the ASC. This feature allows a manager to determine whether the power sources for the transportation cabinet are suspect and need maintenance or whether the intersection is operating on an alternate power source. For example, some ASCs use AC power for its battery.

### **2.5.1.5 Retrieve Operational Performance Data**

A manager needs to retrieve operational data from the ASC for the analysis of the signal timing efficacy. The operational data consists of frequent snapshots of signal operations data and detector data and allows a manager to view the temporal relationship between signal indications and traveler arrivals.

An example of this operational data is the Indiana Traffic Signal Hi Resolution Data Logger Enumerations. This feature provides a manager with the information to evaluate the performance of signal operations, such as the quality of progression of traffic along arterials, or measuring the amount of unused green time during a cycle. A manager may wish to monitor the operational data or store the operational data in a log for retrieval at a later time.

### **2.5.1.6 Manage Auxiliary External Inputs/Outputs**

A manager needs to monitor and control auxiliary external devices (i.e., non-signal control) through the ASC. This feature allows a manager to activate auxiliary external devices or functions that may be tied to other transportation operational needs. For example, the ASC may be co-located with a trail-blazing sign utilized for special events and not associated with traffic signal operations.

### **2.5.1.7 Manage Database**

A manager needs to manage the configuration and version of the database in the ASC. This feature allows a manager to determine if the ASC has the correct and expected version of the database.

### **2.5.1.8 Manage Peer-to-Peer with Other Devices**

A manager needs to configure the ASC to retrieve and transmit data to another NTCIP-compliant device based on an event or events. This feature allows a manager to use events at an ASC as an input to another NTCIP-compliant device. The data is intended for informational purposes only and are not intended to be commands to control another NTCIP-compliant device.

For example, an ASC may detect a light rail at the intersection and then transmit that information to the downstream ASC as an advanced light rail call.

### **2.5.1.9 Manage Signal Monitoring Unit Information**

A manager needs to configure an ASC to be aware of potential malfunctions or errors detected by the SMU. An ASC may be receiving information from the SMU, which is monitoring transportation cabinet operations and conditions. This feature allows a manager to be informed about the traffic signal operations to schedule preventative maintenance or dispatch maintenance crews.

### **2.5.1.10 Manage Interface with External Detectors**

A manager needs to configure an ASC to be aware of potential malfunctions or errors detected by the SMU. An ASC may be receiving information from the SMU, which is monitoring transportation cabinet operations and conditions. This feature allows a manager to be informed about the traffic signal operations to schedule preventative maintenance or dispatch maintenance crews.

## **2.5.2 Manage Signal Operations**

This section identifies and describes the various features for an ASC to monitor and control traffic signal operations. It consists of the following features:

- a) Manage Signal Configuration
- b) Monitor Signal Operations Status
- c) Control Signal Operations

### **2.5.2.1 Manage Signal Configuration**

This feature allows a manager to retrieve and configure the traffic signal operations of an ASC. It consists of the following sub-features.

- a) Manage Controller Startup Functions
- b) Manage Phase Configurations
- c) Manage Coordination Configurations
- d) Manage Timing Patterns
- e) Manage Splits Configurations
- f) Manage Ring Configurations
- g) Manage Channel Configurations
- h) Manage Overlap Configurations
- i) Manage Preempt Configurations
- j) Manage Timing Pattern Scheduler
- k) Manage Action Scheduler
- l) Manage I/O Mapping
- m) Manage Intra-Cabinet Communications Configuration
- n) Manage Pedestrian Support

#### **2.5.2.1.1 Manage Controller Startup Functions**

A manager needs to retrieve and configure the startup capabilities and functions of the ASC. This feature allows a manager to define the startup times upon powerup, set the backup time, and set the minimum clearance times for the ASC.

#### **2.5.2.1.2 Manage Phase Configurations**

For a phase-based controller, a manager needs to retrieve and configure the phases for the ASC. This feature allows a manager to set the minimum durations, maximum durations, clearance times, allowable concurrent phases, and other phase-related features and options for all travel modes (vehicles, pedestrians, bicycles, special vehicles).

#### **2.5.2.1.3 Manage Coordination Configurations**

A manager needs to retrieve and configure the coordination modes for the ASC. This feature allows a manager to configure the allowable operational, correction and force modes, and coordination point within a phase to be used for signal coordination.

#### **2.5.2.1.4 Manage Timing Patterns**

A manager needs to retrieve and configure the timing patterns stored in the ASC. This feature allows a manager to configure each timing pattern, which consists of a cycle length, splits, offsets and the phase sequences. A manager may also specify a default timing pattern.

#### **2.5.2.1.5 Manage Splits Configurations**

A manager needs to retrieve and configure the splits stored in the ASC. This feature allows a manager to configure a split, which consists of the phase assignment, the coordinated phase, the split time, and the split mode.

#### **2.5.2.1.6 Manage Ring Configurations**

A manager needs to retrieve and configure the rings in the ASC. This feature allows a manager to configure each ring, which defines the sequence of phases for that ring.

#### **2.5.2.1.7 Manage Channel Configurations**

A manager needs to retrieve and configure the channel parameters in the ASC. This feature allows a manager to configure the control source, the type of phase the channel is controlling (e.g., vehicle phase, pedestrian phase, bicycle phase, overlap), and the flash and dimming characteristics for each channel.

#### **2.5.2.1.8 Manage Overlap Configurations**

A manager needs to retrieve and configure the overlap functions in the ASC. This feature allows a manager to configure the type of overlap operation, the included phases, the modifier phases, any overlap extensions and clearance times for each overlap.

#### **2.5.2.1.9 Manage Preempt Configurations**

A manager needs to retrieve and configure the preempts in the ASC. Preempts are used to service special needs at an intersection, such as for a railroad crossing or emergency vehicles responding to an incident. This feature allows a manager to retrieve and configure the minimum durations, phase settings, outputs and clearance times whenever a preempt signal is detected, how the controller enters into and exits out of preemption and to define the priority of different preempt inputs into the ASC. This feature also allows a manager to configure the ASC to enable or disable the preempt under certain conditions, such as time-of-day, or to configure the ASC to select alternate exit strategies based on input conditions.

#### **2.5.2.1.10 Manage Timing Pattern Scheduler**

A manager needs to retrieve and configure the scheduler in the ASC to implement a timing pattern based on time. This feature allows a manager to configure the ASC to implement timing patterns based on calendar days, days of the week and/or times of day.

#### **2.5.2.1.11 Manage Action Scheduler**

A manager needs to retrieve and configure the scheduler in the ASC to perform a function or a group of functions. The action scheduler allows a manager to activate an output, enable a parameter (e.g., max2), configure the ASC log, or program the condition-based exception reporting based on calendar days, days of the week and/or times of day.

For example, a manager may program the action scheduler to activate the special function output every weekday when a nearby school is in session and configure the ASC to operate in non-actuated mode during the same period of time. A manager may also configure the log not to record actuations, and to program the condition-based exception reporting not to report actuations during that same period of time.

#### **2.5.2.1.12 Manage I/O Mapping**

A manager needs to retrieve and configure the input/output mapping in the ASC. This feature allows a manager to change the input and outputs for an ASC so unused inputs or outputs, as defined by a standard specification, can be used and configured as needed. This feature also allows a manager to reset the input/output mapping to a default configuration, and configure the conditions when changes to input/output mapping can be accepted by the ASC.

#### **2.5.2.1.13 Manage Intra-Cabinet Communications Configuration**

A manager needs to retrieve and configure the ASC's intra-cabinet communications port. For NEMA TS 2 type controllers, this is the NEMA TS 2 Port 1 in the ASC and allows a manager to indicate if a device is present on Port 1. For controllers in an ATC Cabinet, this is Serial Bus 1 (siuport1).

#### **2.5.2.1.14 Manage Pedestrian Support**

A manager needs to retrieve and configure the ASC to support Accessible Pedestrian Signals (APS). This feature enables an ASC to provide information about pedestrian signal timing to pedestrians via non-visual formats such as audible tones, verbal messages, and/or vibrating surfaces. This may include mobility impaired pedestrians. This feature also allows the ASC to exchange information with pedestrian countdown timers.

### **2.5.2.2 Monitor Signal Operations Status**

This feature allows a manager to monitor the traffic signal operations and status of an ASC. It consists of the following sub-features.

- a) Determine Controller Health
- b) Determine Mode of Operation
- c) Monitor Signal Indication
- d) Monitor Phase Status
- e) Monitor Ring Status
- f) Monitor Channel Status
- g) Monitor Overlap Status
- h) Monitor Preempt Input State
- i) Monitor Preempt State
- j) Monitor Special Function Outputs
- k) Monitor Timebase Action Status
- l) Monitor Intra-Cabinet Communications Configuration
- m) Monitor Peer-to-Peer State
- n) Monitor Signal Monitoring Unit

#### **2.5.2.2.1 Determine Controller Health**

A manager needs to monitor the health of the ASC. This feature allows a manager to determine if the essential functions and elements of the ASC are operating properly. ASC system error conditions and faults to be monitored are processor stall conditions (timeouts), memory faults, task (i.e., process) failures, communication timeouts or errors from a management station, and suspect power problems. ASC operational error conditions and faults to be monitored are conflicts, cycle failures, and coordination failures.

#### **2.5.2.2.2 Determine Mode of Operation**

A manager needs to determine the current mode of operation in the ASC. It consists of the following sub-features.



#### **2.5.2.2.2.1 Monitor Unit-wide General Operations**

A manager needs to determine if the ASC as a unit is operational, provides unit-wide control status information, and monitors other unit-wide parameters such as automatic detector calls, dimming, and interconnect status.

#### **2.5.2.2.2.2 Monitor Flashing**

A manager needs to determine if the ASC is in a flashing condition and the reason for the flashing condition. If a condition is detected in the controller assembly that may comprise public safety, the ASC generally reverts to a flash condition. This feature allows a manager to determine if the cause of a flash condition is normal (e.g., the ASC was commanded to flash) or if a safety critical condition was detected.

#### **2.5.2.2.2.3 Monitor Current Timing Pattern**

A manager needs to retrieve information about the timing pattern, mode of operation and its source (e.g., program entry, time base control, system interface, etc...) running in the ASC. This feature allows a manager to determine the current timing pattern and mode of operation in effect, and the programmed timing pattern and mode of operation (what should be in effect).

#### **2.5.2.2.2.4 Monitor Current Cycle**

A manager needs to retrieve information about the current timing pattern cycle in the ASC. This consists of the current split, its coordination state, the duration of time since the current cycle started, and the duration of time before the current phase ends.

#### **2.5.2.2.3 Monitor Signal Indication**

A manager needs to retrieve the status of each signal indication configured in the ASC. This feature indicates if each signal indication is on, off, flashing or dimmed. This feature allows a manager to view the signal indications on a map.

#### **2.5.2.2.4 Monitor Phase Status**

For a phase-based controller, a manager needs to retrieve the status of each phase configured in the ASC. This feature indicates if each phase is active or not (including clearance intervals) and if there is an active vehicle or pedestrian call. This feature also indicates which phases are expected to be active after the termination of an active phase. This feature allows a manager to observe and review signal operations.

#### **2.5.2.2.5 Monitor Ring Status**

For a phased-based controller, a manager needs to retrieve the status of each ring output configured in the ASC. This feature allows a manager to determine what state (minimum green, extension, yellow change, red clearance, red rest, etc...) and interval the ring is currently in.

#### **2.5.2.2.6 Monitor Channel Status**

A manager needs to retrieve the status of each channel output configured in the ASC. This feature allows a manager to determine if each channel output is red, yellow or green, and the current measured voltages and electrical current.

#### **2.5.2.2.7 Monitor Overlap Status**

A manager needs to retrieve the status of each overlap configured in the ASC. This feature allows a manager to determine if each overlap is red, yellow or green.

#### **2.5.2.2.8 Monitor Preempt Input State**

A manager needs to retrieve the preempt input state for each preempt input configured in the ASC. This feature allows a manager to determine whether an input signal is active on each preempt input of an ASC.

#### **2.5.2.2.9 Monitor Preempt State**

A manager needs to retrieve the status of the preempt state for each preempt input configured in the ASC. For each preempt input, this indicates if the preempt service has started, is being delayed, is linked to another preempt sequence, is overriding another preempt sequence, is being overridden by another preempt sequence, the preempt interval (e.g., in dwell) and if the preempt is exiting out of preempt service.

#### **2.5.2.2.10 Monitor Special Function Outputs**

A manager needs to retrieve if each special function output configured in the ASC is active. For example, an ASC near a school may use its special function outputs to turn on a flashing beacon to indicate a lower speed limit when a timing pattern associated with traffic arriving and leaving the school are in effect.

#### **2.5.2.2.11 Monitor Timebase Action Status**

A manager needs to retrieve which timebase action entry is currently in effect in the ASC.

#### **2.5.2.2.12 Monitor Intra-Cabinet Communications Configuration**

A manager needs to retrieve if the ASC's intra-cabinet communications port is online. For NEMA TS 2 type controllers, this is the NEMA TS 2 Port 1 in the ASC. For traffic signal controllers in an ATC Cabinet, this is Serial Bus 1.

#### **2.5.2.2.13 Monitor Peer-to-Peer State**

A manager needs to retrieve and view the data that an ASC receives or sends to other NTCIP-compliant devices. This feature allows a manager to determine the data being exchanged and the event that resulted in the communication.

#### **2.5.2.2.14 Monitor Signal Monitoring Unit**

A manager needs to retrieve the data that an ASC has received from the Signal Monitoring Unit (SMU) in the cabinet. This feature allows a manager to be aware of potential malfunctions or errors detected by the SMU so a manager may dispatch personnel to remedy the situation or perform preventative maintenance. This feature also allows the ASC to be aware that the transportation cabinet is in cabinet flash, and to confirm the outputs between what the ASC commanded and actual field conditions, depending on the SMU type.

For example, the SMU may detect a loss of current on a signal circuit. The ASC may be configured to record the information to provide to a manager when it detects a configured loss of current on any signal circuit. A loss of current may be indicative of a potential issue that may require preventative maintenance. The SMU also may drive the cabinet to fail-flash (cabinet flash) when it detects a configured loss of current on any signal circuit.

### **2.5.2.3 Control Signal Operations**

This feature allows a manager to control the signal operation of an ASC. It consists of the following sub-features:

- a) Control ASC-wide General Operations
- b) Command Timing Pattern
- c) Phase Requests
- d) Activate Preempt
- e) Control Ring Operations
- f) Activate Special Function Output
- g) Control Frame 40
- h) Activate Action Plan
- i) Remote Manual Control

#### **2.5.2.3.1 Control ASC-wide General Operations**

A manager needs to control ASC-wide operational features within the ASC such as external minimum recalls, automatic detector calls, dimming, interconnect, and enabling/disabling remote commands to the ASC.

#### **2.5.2.3.2 Command Timing Pattern**

A manager needs to command the ASC to a mode of operation, activate a timing pattern or activate a signal plan. This feature allows a manager to command the ASC to a standby mode, to free mode, or to flash, and to establish the system reference point.

#### **2.5.2.3.3 Phase Requests**

A manager needs to control the duration and inclusion of phases for the current (signal) cycle of an ASC. This feature consists of the capability to omit phases, hold phases, force phases off, and to place calls.

#### **2.5.2.3.4 Activate Preempt**

A manager needs to activate a preempt input configured in the ASC. This feature allows a manager to force the ASC to request a preempt sequence state for diagnostic purposes or during special events.

#### **2.5.2.3.5 Control Ring Operations**

A manager needs to control ring operations of an ASC. This feature allows a manager to stop the ring timing, to activate a force off, or force the ring to rest in red.

#### **2.5.2.3.6 Activate Special Function Output**

A manager needs to activate a special function output configured in an ASC. This special function output may be used to activate other devices, such as flashing beacon or a blank out sign associated with a timing pattern.

#### **2.5.2.3.7 Control Frame 40**

For NEMA TS 2 type controllers, a manager needs to enable or disable Frame 40 messages from the ASC to a device at the Port 1 address. Frame 40 is used to poll the secondary stations for a secondary-to-secondary message exchange.

#### **2.5.2.3.8 Activate Action Plan**

A manager needs to activate a pre-defined group of functions configured in an ASC. This feature allows a manager to command the ASC to perform a group of functions. The functions consist of allowing a manager to activate an output, configure the ASC (e.g., max2), configure the ASC log, or program the condition-based exception reporting.

#### **2.5.2.3.9 Remote Manual Control**

A manager needs to command the ASC to remotely advance the signal controller through the phases or intervals. This feature allows a manager to remotely and manually control a signal controller. Examples of when a manager may wish to manually control an intersection would be for special events, such as sporting events, parades and large concerts, where traffic congestion is far in excess of normal volumes.

### **2.5.3 Manage Detectors**

This section identifies and describes the various features to monitor and control the detector inputs to the ASC. A detector may be used to identify demand for signal service. The user needs to monitor and control detector inputs consist of the following features:

- a) Manage Detector Configuration
- b) Monitor Detector Status
- c) Monitor Detector Health
- d) Control Detectors
- e) Manage Detector Data
- f) Monitor Detector Data from External Devices

#### **2.5.3.1 Manage Detector Configuration**

A manager needs to retrieve and configure the detectors connected to the ASC. This feature allows a manager to define the travel mode being detected (vehicle, pedestrian, transit, and bicycle), select phase assignments, define capabilities, and define the criteria for detector faults. The criteria for a detector fault consist of the amount of time between detector actuations, amount of time with continuous actuations, and excessive actuations over a period of time.

#### **2.5.3.2 Monitor Detector Status**

A manager needs to monitor activations for detectors configured in the ASC. This feature allows a manager to determine the presence of vehicles, pedestrians or other travelers on the roadway.

#### **2.5.3.3 Monitor Detector Health**

A manager needs to monitor the health of the detectors configured in the ASC. This feature allows a manager to determine if the detectors are operating correctly or if a fault has been detected so maintenance personnel can be dispatched to repair the detectors if necessary.

#### **2.5.3.4 Control Detectors**

A manager needs to control a detector configured in the ASC. This feature allows a manager to clear a detector fault and place the detector back in service, and to activate a call on a detector.

#### **2.5.3.5 Manage Detector Data**

A manager needs to set up the ASC to collect data from detectors configured in the ASC. This feature allows a manager to retrieve reports from the ASC on the data measured by the detectors over a user-defined period. This data consists of volumes, occupancies, and speeds as appropriate.

### 2.5.3.6 Monitor Detector Data from External Detectors

A manager needs to monitor the detector data received from external detectors. This feature allows a manager to retrieve reports from the ASC on the data received from external detectors.

### 2.5.4 Manage Connected Vehicles Interface

This section identifies and describes the various features that support the interface between an ASC and a CV Roadside Process in a connected vehicle environment. The connected vehicle environment is expected to use the SAE J2735 – V2X Communications Message Set Dictionary as the information standard. Several messages in SAE J2735 are pertinent to ASCs and are addressed within NTCIP 1202 v04. These messages are:

- a) **Signal Phase and Timing (SPaT) Message.** A broadcasted message providing signal phase and timing information for one or more ASC indicating the state of each permitted intersection maneuver and when an active maneuver terminates. The current signal status is also sent. This message is intended for connected devices in the broadcast vicinity of an ASC.
- b) **Basic Safety Message.** A broadcasted message providing "basic" information about the location and movements of a "connected" vehicle, including its current location, speed, acceleration, and direction of travel.
- c) **Personal Safety Message.** A broadcasted message providing "basic" information about the location and movements of a "connected" mobile device carried by a Vulnerable Road User (VRU), such as a pedestrian, bicyclist or road worker, or integrated in a device used by the VRU, such as a bicycle or wheelchair.

The features offered by an ASC to support the connected vehicle environment are organized by interface:

- a) the interface between a management station and the ASC; and
- b) the interface between the ASC and the CV Roadside Process.

#### 2.5.4.1 Connected Vehicle Interface: Management Station – ASC Interface

The following subsections identify and describe the various features that may be offered between a management station and an ASC. These features are:

- a) Manage CV Roadside Process Interface
- b) Manage CV Roadside Process Interface Watchdog
- c) Manage Signal Phase and Timing Data
- d) Exchange Connected Devices Data for Operational Performance Data
- e) Manage Assured Green Period
- f) Monitor External Local Control Application State

##### 2.5.4.1.1 Manage CV Roadside Process Interface

A manager needs to retrieve and configure the interface between the ASC and a CV Roadside Process. This feature allows a manager to configure operational control information of how often information is exchanged between the ASC and an CV Roadside Process.

##### 2.5.4.1.2 Manage CV Roadside Process Interface Watchdog

A manager needs to retrieve and configure an CV Roadside Process watchdog within the ASC. This feature allows the ASC to monitor the period of time elapsed between data exchanges across an ASC and CV Roadside Process interface. If the time elapsed exceeds a configured threshold, the ASC hardware is reset to clear the potential stall condition.

### **2.5.4.1.3 Manage Signal Phase and Timing Data**

Some of the key applications that have been developed within the connected vehicle environment are related to intersection safety. For signalized intersections, this involves an RSU broadcasting SPaT messages, as defined by SAE J2735, to connected vehicles in the vicinity. Nearly all the data in the SPaT message originates from the ASC, so the ASC needs to exchange this data with the CV Roadside Process. However, a manager in a traffic management center needs to monitor what data is being provided to the CV Roadside Process to broadcast to connected devices. This feature allows a manager to manage and view the contents of the signal phase and timing data that the ASC is exchanging with the CV Roadside Process.

### **2.5.4.1.4 Exchange Connected Devices Data for Operational Performance Data**

A manager needs to retrieve data about connected devices traversing the roadway in the vicinity of the ASC. This data consists of frequent snapshots about connected devices in the vicinity of the ASC and allows a manager to view the temporal relationship between signal indications and traveler arrivals. This feature allows a manager to integrate phase and timing information with data from connected devices to produce performance metrics related to intersection demand, safety, and operations.

### **2.5.4.1.5 Manage Assured Green Period**

A manager needs to configure the ASC to provide an Assured Green Period (AGP) at connected intersections. This feature allows a manager to define the parameters to calculate the AGP, establish a Red Light Violation Warning (RLVW) detection zone (RDZ), and the ability to provide an assured green end time (AGET) when the intersection is under actuated signal control.

The RLVW application decreases the likelihood that the vehicle will be in the intersection during a red signal indication. When a vehicle is approaching an intersection during a green interval, the RLVW application may provide advisories, warnings, or alerts to the driver that they may not clear the intersection before the signal turns red.

### **2.5.4.1.6 Manage External Control Local Application State**

A manager needs to configure the ASC to exchange information with an External Control Local Application (ECLA) that is asserting a higher-level control over the ASC. This feature allows a manager to enable the ASC to exchange information with an ECLA so the ASC can generate accurate SPaT data to a CV Roadside Process. This data includes signal timing durations that are selected by the ECLA.

## **2.5.4.2 Connected Vehicle Interface: ASC – CV Roadside Process Interface**

The following subsections identify and describe the various features that may be offered between an ASC and a CV Roadside Process. These features are:

- a) Exchange Current and Next Movement Information
- b) Exchange Next Occurrence of a Movement
- c) Exchange Presence of Connected Devices
- d) Exchange Roadway Geometrics Information
- e) Exchange Movement Configuration

### **2.5.4.2.1 Exchange Current and Next Movement Information**

An ASC needs to exchange with a CV Roadside Process what the current and future states of each movement is and when that state will change. This feature allows the ASC to exchange information about when each state of each movement starts and ends. The CV Roadside Process uses this information for its safety, mobility and environmental applications and to broadcast SPaT messages to connected vehicles and mobile devices. An ASC operating in actuated mode might only be able to provide a time

period when an active movement is to terminate. An ASC also may not be able to provide about the next active movement until the end of a current active movement.

#### **2.5.4.2.2 Exchange Next Occurrence of a Movement**

An ASC needs to exchange with a CV Roadside Process the time when each movement will be next permitted (when it is permitted to move again). One of the applications envisioned for the connected vehicle environment is Connected Eco-Driving. This application provides customized real-time driving advice to drivers so that they can adjust their driving behavior to save fuel and reduce emissions. This may include a CV application in the CV Roadside Process providing recommendations for an optimal speed to equipped vehicles so vehicles arrive at the intersection when the signal indication for their desired movement is green, reducing fuel consumption and emissions created when a vehicle unnecessarily brakes and accelerates.

#### **2.5.4.2.3 Exchange Presence of Connected Devices**

An ASC needs to exchange with a CV Roadside Process the presence of connected devices on the roadway around the ASC in support of the Assured Green Period. This feature allows the ASC to exchange with the CV Roadside Process information that can be used as a call for actuated movements or to determine the demand for specific movements. The Basic Safety Message and the Personal Safety Message are the primary sources of presence information that are received by a CV Roadside Process located near the ASC and then exchanged with the ASC.

#### **2.5.4.2.4 Exchange Roadway Geometrics Information**

An ASC needs to exchange with a CV Roadside Process what roadway geometry plan that is currently in effect at the intersection. Each roadway geometry plan may define the pathways where movements are permitted at the intersection when that roadway geometry plan is in effect. A pathway may be a vehicle lane, a pedestrian crossing, a bicycle lane, or a transit right of way. This feature allows the ASC to exchange with the CV Roadside Process when the roadway geometry plan in effect in the ASC has changed. The ASC uses this information to confirm that the roadway geometry plan is compatible with the signal operations timing plan in effect.

For example, an ASC may be programmed to use signal timing plans with an intersection roadway geometry with one-way approaches into the intersection. However, if the intersection roadway has been changed to two-way traffic, the ASC needs to confirm that the signal timing plan in effect is still compatible with the new roadway geometry plan that the CV Roadside Process is broadcasting to travelers.

### **2.5.5 Backward Compatibility Features**

Prior versions of NTCIP 1202 use SNMPv1 as its application layer protocol, while NTCIP 1202 v04 uses SNMPv3 as its application layer protocol. A shortcoming of SNMPv1 is its lack of security – thus *NTCIP 9014, Infrastructure Standards Security Assessment (ISSA)*, published in 2021, recommended migrating the NTCIP center-to-field standards from SNMPv1 to SNMPv3. However, an authentication feature in SNMPv3 breaks backward compatibility for every SNMPv1 message exchanged, thus NTCIP 1202 v04 is not backward compatible with previous versions of NTCIP 1202, so this section is not applicable.

## **2.6 Security**

Section 2.6 identifies and describes the various security features that may be offered by the ASC. It consists of the following sub-features:

- a) Manage Authentication
- b) Manage Accessibility
- c) Manage Users

- d) Log User Access
- e) Manage ASC Interface Security

### **2.6.1 Manage Authentication**

A manager needs to retrieve and configure the ASC to authenticate requests from a manager. This feature allows a manager to authenticate users and passwords in the ASC.

### **2.6.2 Manage Accessibility**

A manager needs to retrieve and configure the ASC to limit access to specific information in the ASC based on the permissions assigned by a manager.

### **2.6.3 Manage Users**

A manager needs to retrieve and configure a user's profile in the ASC. Each user profile consists of a user, its password and its access rights.

### **2.6.4 Log User Access**

A manager needs to retrieve and configure the ASC to log when and what requests were made by a manager. This feature allows a manager to track who made what changes to the ASC security configuration, or commanded the ASC to perform a security-related function. This feature is only accessible by a system administrator.

### **2.6.5 Manage ASC Interface Security**

The following subsections identify and describe the various security features for the interfaces between the ASC and other devices and processes. These features are:

#### **2.6.5.1 Manage Security for the ASC to RSU Interface**

A manager needs to manage the security features for the ASC to the RSU communications interface as defined by other ITS standards. Other ITS standards may impose additional needs on this communications interface.

#### **2.6.5.2 Manage Security for Other ASC Interfaces**

A manager needs to manage the security features for the communications interface between the ASC and other devices or processes. These security features may be defined by other ITS standards.

## **2.7 Operational Policies and Constraints**

The ASC WG recognize that the following constraints may apply.

- Public agencies may implement operational policies, rules, or regulations that takes precedence over the use of this standard. No governmental operational policies, rules or regulation shall be violated when applying NTCIP 1202.
- It is the operational policy of some agencies that authorized personnel is/are present at the physical location of the ASC, before an ASC accepts a change to the configuration of the ASC. This operational policy is usually enforced by requiring that the door of the transportation cabinet containing the ASC is open.
- The operation and maintenance of the connected signalized intersection uses the traffic signal timing principles and practices that have guided signal timing operations for many decades. Many of these principles and practices have been studied, researched, and time tested. Significant



changes to these principles and practices may require additional studies and research before they can be adopted and deployed.

## 2.8 Relationship to the ITS National Architecture [Informative]

Architecture Reference for Cooperative and Intelligent Transportation, known as ARC-IT, combines the National ITS Architecture and the Connected Vehicle Reference Implementation Architecture (CVRIA). NTCIP 1202 v04 addresses many ARC-IT flows associated with the operation of an ASC.

NTCIP 1202 v04 addresses fourteen (14) ARC-IT flows between a Traffic Management Center (TMC) and a Traffic Signal Controller (ITS Roadway Equipment (IRE)) that are associated with the operation of an ASC. These flows are:

- a) **Rail Crossing Control Data:** Data required for Highway-Rail Intersection (HRI) information transmitted at railroad grade crossings and within railroad operations.
- b) **Rail Crossing Request:** A request for highway-rail intersection status or a specific control request intended to modify HRI operation.
- c) **Rail Crossing Status:** Status of the highway-rail intersection equipment including both the current state or mode of operation and the current equipment condition.
- d) **Right-of-Way Request Notification:** Notice that a request has occurred for signal prioritization, signal preemption, pedestrian call, multi-modal crossing activation, or other sources for right-of-way requests.
- e) **Signal Control Commands:** Control of traffic signal controllers or field masters including clock synchronization.
- f) **Signal Control Coordination:** The direct flow of information between field equipment. This includes configuration and control of traffic signal controllers and field masters. Configuration data and operational status of traffic signal control equipment including operating condition and current indications are returned.
- g) **Signal Control Device Configuration:** Data used to configure traffic signal control equipment including local controllers and system masters.
- h) **Signal Control Plans:** Traffic signal timing parameters including minimum green time and interval durations for basic operation and cycle length, splits, offset, phase sequence, etc. for coordinated systems.
- i) **Signal Control Status:** Operational and status data of traffic signal control equipment including operating conditions and current indications.
- j) **Signal Fault Data:** Faults from traffic signal control equipment.
- k) **Signal System Configuration:** Data used to configure traffic signal systems including configuring control sections and mode of operation (time-based or traffic responsive).
- l) **Traffic Detector Data:** Raw and/or processed traffic detector data which allows derivation of traffic flow variables (e.g., speed, volume, and density measures) and associated information (e.g., congestion, potential incidents). This flow includes the traffic data and the operational status of the traffic detectors.
- m) **Traffic Detector Control:** Information used to configure and control traffic detector systems such as inductive loop detectors and machine vision sensors.

NTCIP 1202 v04 also addresses fifteen (15) ARC-IT flows between a Traffic Signal Controller, represented as an ITS Roadway Equipment (IRE), and an RSU, represented as a Connected Vehicle Roadside Equipment (CVRE). These flows are:

- a) **Arriving Train Information:** Information for a train approaching a highway-rail intersection that may include direction and allow calculation of approximate arrival time and closure duration.
- b) **Conflict Monitor Status:** A control flow that supports failsafe operation in the event that a conflict is detected that requires the RSE to enter a failsafe operating mode.
- c) **Intersection Control Status:** Status data provided by the traffic signal controller including phase information, alarm status, and priority/preempt status.

- d) **Intersection Infringement Info:** Vehicle path information sent by a vehicle that is violating the stop bar at an intersection. This flow includes the vehicle's position, heading, speed, acceleration, transmission, steering-wheel angle, braking status, size information, and trajectory.
- e) **Intersection Status Monitoring:** Current signal phase and timing information for all lanes at a signalized intersection. This flow identifies monitoring of communications by a receiver at the intersection to support monitoring for conflicts between actual signal states and RSE communications about those states.
- f) **Mixed Use Crossing Status:** Current pedestrian and other non-motorized user locations including an indication of whether the call button has been activated, the current state of the mixed-use crossing signal, and information indicating whether non-motorized users are currently occupying the cross walk.
- g) **Personal Location Information:** Pedestrian, bicyclist, and other non-motorized user locations at an intersection as detected and reported by an RSE.
- h) **Signal Preemption Request:** Direct request for preemption to a traffic signal controller that results in preemption of the current control plan and grants right-of-way to the requesting vehicle. This flow identifies the required phase and timing of the preemption. This flow may also cancel the preemption request (e.g., when the requesting vehicle clears the intersection).
- i) **Signal Service Request:** A call for service or extension for a signal control phase that is issued by the RSE for connected vehicles approaching an intersection and/or pedestrians at a crosswalk. This flow identifies the desired phase and service time.
- j) **Track Status:** Current status of the wayside equipment and notification of an arriving train.
- k) **Traffic Situation Data:** Current, aggregate traffic data collected from connected vehicles that can be used to supplement or replace information collected by roadside traffic detectors. It includes raw and/or processed reported vehicle speeds, counts, and other derived measures. Raw and/or filtered vehicle control events may also be included to support incident detection.
- l) **Vehicle Entries and Exit:** Information exchanged between an RSE and ITS Roadway Equipment (ASC) that supports detection of non-equipped vehicles in an automated lane, low emissions zone, or other facility where V2I communications is used to monitor vehicles at entry or exit points. This exchange also supports identification of non-equipped vehicles where an RSE is used for payment collection. This generic exchange can be implemented by any approach that compares vehicle detections with V2I communications by the RSE to identify vehicles that are not equipped or are otherwise unable to communicate with the RSE.