

NTCIP 1202 Version 04

National Transportation Communications for ITS Protocol

FRS Walkthrough Workbook:

Object Definitions for Actuated Signal Controllers (ASC) Interface

Draft v04.02f February 9, 2024

This is a draft document, which is distributed for review and comment purposes only. You may reproduce and distribute this document within your organization, but only for the purposes of and only to the extent necessary to facilitate review and comment to the NTCIP Coordinator.

Please ensure that all copies include this notice. This document contains preliminary information that is subject to change.

Published by

American Association of State Highway and Transportation Officials (AASHTO)
444 North Capitol Street, N.W., Suite 249
Washington, D.C. 20001

Institute of Transportation Engineers (ITE)
1627 Eye Street, N.W., Suite 550
Washington, D.C. 20006

National Electrical Manufacturers Association (NEMA)
1300 North 17th Street, Suite 900
Rosslyn, Virginia 22209-3801

Content highlighted in **yellow** need to be updated prior to publication.
Content highlighted in **cyan** need to be discussed by the ASC WG.

REVISION HISTORY

Filename	Version	Date	Notes
NTCIP 1202v04.02f.docx	04.02f	2/9/24	Chan – Submit to USDOT
NTCIP 1202v04.02e.docx	04.02e	2/6/24	Chan – Sent to co-chairs, Wyatt, Lahiri for QA
NTCIP 1202v04.02a.docx	04.02a	6/9/23	Chan – QA, New requirements from new user needs
NTCIP 1202v04.02.docx	04.02	6/1/23	Lahiri – Initial draft with Functional Requirements
NTCIP 1202v04.01a.docx	04.01a	5/1/23	Chan – Submitted to ASC WG and USDOT. Final ConOps
NTCIP 1202v04.01.docx	04.01	4/27/23	Lahiri – Addresses ConOps Walkthrough comments
NTCIP 1202v04.00a.docx	04.00a	3/15/23	Chan – Submitted to ASC WG and USDOT. Initial Draft ConOps
NTCIP 1202v04.00.docx	04.00	3/11/23	Lahiri – Initial Draft

NOTICES

Copyright Notice

© 2024 by the American Association of State Highway and Transportation Officials (AASHTO), the Institute of Transportation Engineers (ITE), and the National Electrical Manufacturers Association (NEMA). All intellectual property rights, including, but not limited to, the rights of reproduction, translation, and display are reserved under the laws of the United States of America, the Universal Copyright Convention, the Berne Convention, and the International and Pan American Copyright Conventions. Except as licensed or permitted, you may not copy these materials without prior written permission from AASHTO, ITE, or NEMA. Use of these materials does not give you any rights of ownership or claim of copyright in or to these materials.

Visit www.ntcip.org for other copyright information, for instructions to request reprints of excerpts, and to request reproduction that is not granted below.

PDF File License Agreement

To the extent that these materials are distributed by AASHTO / ITE / NEMA in the form of an Adobe® Portable Document Format (PDF) electronic data file (the "PDF file"), AASHTO / ITE / NEMA authorizes each registered PDF file user to view, download, copy, or print the PDF file available from the authorized Web site, subject to the terms and conditions of this license agreement:

- a) you may download one copy of each PDF file for personal, noncommercial, and intraorganizational use only;
- b) ownership of the PDF file is not transferred to you; you are licensed to use the PDF file;
- c) you may make one more electronic copy of the PDF file, such as to a second hard drive or burn to a CD;
- d) you agree not to copy, distribute, or transfer the PDF file from that media to any other electronic media or device;
- e) you may print one paper copy of the PDF file;
- f) you may make one paper reproduction of the printed copy;
- g) any permitted copies of the PDF file must retain the copyright notice, and any other proprietary notices contained in the file;
- h) the PDF file license does not include (1) resale of the PDF file or copies, (2) republishing the content in compendiums or anthologies, (3) publishing excerpts in commercial publications or works for hire, (4) editing or modification of the PDF file except those portions as permitted, (5)

- posting on network servers or distribution by electronic mail or from electronic storage devices, and (6) translation to other languages or conversion to other electronic formats;
- i) other use of the PDF file and printed copy requires express, prior written consent.

Data Dictionary and MIB Distribution Permission

To the extent that these materials are distributed by AASHTO / ITE / NEMA in the form of a Data Dictionary ("DD") or Management Information Base ("MIB"), AASHTO / ITE / NEMA extend the following permission:

You may make or distribute unlimited copies, including derivative works, of the DD or MIB, including copies for commercial distribution, provided that:

- a) each copy you make or distribute includes the citation "Derived from NTCIP 0000 [insert the standard number]. Copyright by AASHTO / ITE / NEMA. Used by permission.";
- b) the copies or derivative works are not made part of the standard publications or works offered by other standard developing organizations or publishers or as works-for-hire not associated with commercial hardware or software products intended for field implementation;
- c) use of the DD or MIB is restricted in that the SYNTAX fields may only be modified to define: 1) a more restrictive subrange; or 2) a subset of the standard enumerated values; or 3) a set of retired and defined enumerated values for systems supporting multiversion interoperability;
- d) the description field may be modified but only to the extent that: 1) the more restrictive subrange is defined; and 2) only those bit values or enumerated values that are supported are listed.
[from 8002 A2 v04]

These materials are delivered "AS IS" without any warranties as to their use or performance.

AASHTO / ITE / NEMA and their suppliers do not warrant the performance or results you may obtain by using these materials. AASHTO / ITE / NEMA and their suppliers make no warranties, express or implied, as to noninfringement of third party rights, merchantability, or fitness for any particular purpose. In no event will AASHTO / ITE / NEMA or their suppliers be liable to you or any third party for any claim or for any consequential, incidental or special damages, including any lost profits or lost savings, arising from your reproduction or use of these materials, even if an AASHTO / ITE / NEMA representative has been advised of the possibility of such damages.

Some states or jurisdictions do not allow the exclusion or limitation of incidental, consequential, or special damages, or the exclusion of implied warranties, so the above limitations may not apply to a given user.

Use of these materials does not constitute an endorsement or affiliation by or between AASHTO, ITE, or NEMA and the user, the user's company, or the products and services of the user's company.

If the user is unwilling to accept the foregoing restrictions, he or she should immediately return these materials.

PRL and RTM Distribution Permission

To the extent that these materials are distributed by AASHTO / ITE / NEMA in the form of a Protocol Requirements List ("PRL") or a Requirements Traceability Matrix ("RTM"), AASHTO / ITE / NEMA extend the following permission:

- a) you may make or distribute unlimited copies, including derivative works of the PRL (then known as a Profile Implementation Conformance Statement ("PICS")) or the RTM, provided that each copy you make or distribute contains the citation "Based on NTCIP 0000 [insert the standard number] PRL or RTM. Used by permission. Original text © AASHTO / ITE / NEMA.";

- b) you may only modify the PRL or the RTM by adding: 1) text in the Project Requirements column, which is the only column that may be modified to show a product's implementation or the project-specific requirements; and/or 2) additional table columns or table rows that are clearly labeled as ADDITIONAL for project-unique or vendor-unique features; and
- c) if the PRL or RTM excerpt is made from an unapproved draft, add to the citation "PRL (or RTM) excerpted from a draft standard containing preliminary information that is subject to change."

This limited permission does not include reuse in works offered by other standards developing organizations or publishers, and does not include reuse in works-for-hire, compendiums, or electronic storage devices that are not associated with procurement documents, or commercial hardware, or commercial software products intended for field installation.

A PRL is completed to indicate the features that are supported in an implementation. Visit www.ntcip.org for information on electronic copies of the MIBs, PRLs, and RTMs.

TRF Distribution Permission

A Testing Requirements Form ("TRF") may be a Testing Requirements Traceability Table and/or Test Procedures. To the extent that these materials are distributed by AASHTO / ITE / NEMA in the form of a TRF, AASHTO / ITE / NEMA extend the following permission:

- a) you may make and/or distribute unlimited electronic or hard copies, including derivative works of the TRF, provided that each copy you make and/or distribute contains the citation "Based on NTCIP 0000 [insert the standard number] TRF. Used by permission. Original text © AASHTO / ITE / NEMA.";
- b) you may not modify the logical flow of any test procedure, without clearly noting and marking any such modification; and
- c) if the TRF excerpt is made from an unapproved draft, add to the citation "TRF excerpted from a draft standard containing preliminary information that is subject to change."

Content and Liability Disclaimer

The information in this publication was considered technically sound by the consensus of persons engaged in the development and approval of the document at the time it was developed. Consensus does not necessarily mean that there is unanimous agreement among every person participating in the development of this document.

AASHTO, ITE, and NEMA standards and guideline publications, of which the document contained herein is one, are developed through a voluntary consensus standards development process. This process brings together volunteers and seeks out the views of persons who have an interest in the topic covered by this publication. While AASHTO, ITE, and NEMA administer the process and establish rules to promote fairness in the development of consensus, they do not write the document and they do not independently test, evaluate, or verify the accuracy or completeness of any information or the soundness of any judgments contained in their standards and guideline publications.

AASHTO, ITE, and NEMA disclaim liability for any personal injury, property, or other damages of any nature whatsoever, whether special, indirect, consequential, or compensatory, directly or indirectly resulting from the publication, use of, application, or reliance on this document. AASHTO, ITE, and NEMA disclaim and make no guaranty or warranty, express or implied, as to the accuracy or completeness of any information published herein, and disclaims and makes no warranty that the information in this document will fulfill any of your particular purposes or needs. AASHTO, ITE, and NEMA do not undertake to guarantee the performance of any individual manufacturer or seller's products or services by virtue of this standard or guide.

In publishing and making this document available, AASHTO, ITE, and NEMA are not undertaking to render professional or other services for or on behalf of any person or entity, nor are AASHTO, ITE, and NEMA undertaking to perform any duty owed by any person or entity to someone else. Anyone using this document should rely on his or her own independent judgment or, as appropriate, seek the advice of a competent professional in determining the exercise of reasonable care in any given circumstances. Information and other standards on the topic covered by this publication may be available from other sources, which the user may wish to consult for additional views or information not covered by this publication.

AASHTO, ITE, and NEMA have no power, nor do they undertake to police or enforce compliance with the contents of this document. AASHTO, ITE, and NEMA do not certify, test, or inspect products, designs, or installations for safety or health purposes. Any certification or other statement of compliance with any health or safety-related information in this document shall not be attributable to AASHTO, ITE, or NEMA and is solely the responsibility of the certifier or maker of the statement.

Acknowledgements

NTCIP 1202 v04 was prepared by the NTCIP Actuated Signal Controller Working Group (ASC WG), which is a subdivision of the Joint Committee on the NTCIP. The NTCIP Joint Committee is organized under a Memorandum of Understanding among the American Association of State Highway and Transportation Officials (AASHTO), the Institute of Transportation Engineers (ITE), and the National Electrical Manufacturers Association (NEMA). The NTCIP Joint Committee consists of six representatives from each of the standards organizations, and provides guidance for NTCIP development.

When NTCIP 1202 v04 was prepared, the following individuals were voting (indicated by an asterisk) or alternate voting members of the NTCIP ASC WG:

- City of Anaheim, John Thai* (Co-Chair)
- California Department of Transportation, Mike Robinson*, Jay Schultz
- Econolite Control Products, Inc., Doug Tarico* (Co-Chair), Dustin DeVoe, Dan Brandesky
- Florida Department of Transportation, Matthew DeWitt*, Jeffrey Morgan, Derek Vollmer
- Minnesota Department of Transportation, Ray Starr*, Terry Haukom, Peter Skweres
- Nissan Motor Co., Roy Goudy*
- Oregon Department of Transportation, Christopher Primm*
- Pillar Consulting, Ralph Boaz*
- Texas A&M University (TTI), Kevin Balke*, Hassan Charara, Srinivasa Sunkari
- TransCore ITS, Robert Rausch*, Keith Patton
- Yunex Traffic, Jonathan Grant*, Dave Miller, Iouri Nemirovski

Observing members include:

- Caliper Corporation, Wuping Xin
- Consensus Systems Technologies, Patrick Chan, Manny Insignares, AJ Lahiri, Joerg 'Nu' Rosenbohm
- Florida DOT, Ronald Meyer
- Michigan DOT, Bashir Choudry
- Noblis, Justin Anderson, Mike Mercer
- Oregon Department of Transportation, Roger Boettcher
- Oriux, Ray Deer, Joe Socci
- Parsons Transportation Group, Jon Wyatt, Dmitri Khijniak
- SWARCO McCain Inc., Mark Simpson
- Trevilon Corp., Kenneth Vaughn
- Utah DOT, Mike Blanchette

Additional stakeholders who provided input or monitored development include:

- CAMP, Jay Parikh
- Cubic, Shaun Alford
- City of Toronto, Rakesh Patel
- DKS & Associates, Alan Clelland
- Gresham Smith, James Anderson
- GreenFactor, Canny Quach
- Iteris, Frank Provenzano
- KLD, Satya Muthuswamy
- Leidos, Archak Mittal
- Maricopa County DOT, April Wire
- Miovision, Greg Barlow, Christian Kulus
- Mixon Hill, Christopher Poe, Jackson Holderman
- NoTraffic, Craig Hinners
- OmniAir, Randy Roebuck
- Oriux, Ray Deer, Joe Socci
- Q-Free, Douglas Crawford, Patrick Marnell
- SANDAG, Peter Thompson
- Seattle DOT, Michael Mullen
- Skyline Technology Solution, Israel Lopez
- City of Toronto, Rakesh Patel
- UTA, Taylor Li
- WSP, Eric Gionet

In addition to the many volunteer efforts, recognition is also given to those organizations that supported the effort by providing funding:

- U.S. Department of Transportation

Foreword

NTCIP 1202 v04, an NTCIP standards publication, identifies and defines how a management station may wish to interface with a field device to control and monitor traffic signal controllers and associated detectors in an NTCIP-conformant fashion. NTCIP 1202 v04 may also identify and define how a traffic signal controller NTCIP 1202 v04 uses only metric units.

NTCIP 1202 v04 is titled Actuated Signal Controllers (ASC) Interface Protocol to express the multiple sections and annexes that are included in NTCIP 1202 v04. This NTCIP 1200-series standards publication has grown beyond the "object definitions" that were reflected in the title for its predecessors, NTCIP 1202 versions v01 (1996), v02 (2005), v03 (2018).

NTCIP 1202 v04 defines data elements for use with Actuated Signal Controller Units. The data is defined using the Simple Network Management Protocol (SNMP) object-type format as defined in RFC 1212 and the defined NTCIP format defined in NTCIP 8004. This data would typically be exchanged using one of the NTCIP 1103 recognized Application Layers (e.g., SNMP). Previous versions of NTCIP 1202 used SNMPv1. NTCIP 1202 v04 uses SNMPv3 and does not support SNMPv1.

NTCIP 1202 v04 follows an established systems engineering approach to support procurement processes. The PRL is designed to allow an agency to indicate what user needs are applicable to a procurement, and to select which requirements are to be implemented in a project specific implementation. Proper completion of the PRL by the agency results in a specification that is more likely to satisfy the agency's project needs and that is conformant to NTCIP 1202 v04. The RTM defines the interface specifications for those requirements selected, and can be used to develop the test plans and test procedures.

The following keywords apply to this document: AASHTO, ITE, NEMA, NTCIP, ASC, data, data dictionary, object, MIB, PRL and RTM.

NTCIP 1202 v04 includes a number of normative and informative annexes.

NTCIP 1202 v04 is also an NTCIP Data Dictionary standard. Data Dictionary standards provide definitions of data concepts (messages, data frames, and data elements) for use within NTCIP systems; and are approved by AASHTO, ITE, and NEMA through a ballot process, after a recommendation by the NTCIP Joint Committee. For more information about NTCIP standards, or to acquire the related NTCIP 1202 v04 MIB, visit www.ntcip.org.

User Comment Instructions

The term "User Comment" includes any type of written inquiry, comment, question, or proposed revision, from an individual person or organization, about any NTCIP 1202 v04 content. A "Request for Interpretation" is also classified as a User Comment. User Comments are solicited at any time. In preparation of this NTCIP standards publication, input of users and other interested parties was sought and evaluated.

User Comments are generally referred to the committee responsible for developing and/or maintaining NTCIP 1202 v04. The committee chairperson, or their designee, may contact the submitter for clarification of the User Comment. When the committee chairperson or designee reports the committee's consensus opinion related to the User Comment, that opinion is forwarded to the submitter. The committee chairperson may report that action on the User Comment may be deferred to a future committee meeting and/or a future revision of the standards publication. Previous User Comments and their disposition may be available for reference and information at www.ntcip.org.

A User Comment should be submitted to this address:

NTCIP Coordinator
National Electrical Manufacturers Association
1300 North 17th Street, Suite 900
Rosslyn, Virginia 22209-3801
e-mail: ntcip@nema.org

A User Comment should be submitted in the following form:

Standard Publication number and version:
Page:
Section, Paragraph, or Clause:
Comment:
Editorial or Substantive?:
Suggested Alternative Language:

Please include your name, organization, and address in your correspondence.

Approvals

To be completed prior to publication.

History

In 1992, the NEMA 3TS Transportation Management Systems and Associated Control Devices Section began the effort to develop NTCIP. Under the guidance of the Federal Highway Administration's NTCIP Steering Group, the NEMA effort was expanded to include the development of communications standards for all transportation field devices that could be used in an ITS network.

In September 1996, an agreement was executed among AASHTO, ITE, and NEMA to jointly develop, approve, and maintain the NTCIP standards. In late 1998, the Actuated Signal Controller Working Group was tasked with the effort to update the Actuated Traffic Signal Controller Object Definitions document. The first meeting of this working group was held in October 1999. From 1996 to 1999, this document was referenced as NEMA TS 3.5-1996. However, to provide an organized numbering scheme for the NTCIP documents, this document is now referenced as NTCIP 1202. As included in the following development history, NTCIP 1202 has experienced revisions over time:

NEMA TS 3.5-1996. 1996 – Approved by NEMA. 1996 – Accepted as a Recommended Standard by the Joint Committee on the NTCIP. 1997 – Approved by AASHTO and ITE.
v01.07a printed with NEMA cover.

NTCIP 1202 v01. v01.07b printed with joint cover. v01.07c printed to PDF in November 2002.
v01.07d printed to PDF for no-cost distribution January 2005.

NTCIP 1202 Amendment 1. November 1999 – Accepted as a User Comment Draft Amendment by the Joint Committee on the NTCIP. April 2000 – NTCIP Standards Bulletin B0049 sent NTCIP 1202 Amendment 1 v01.06b for user comment. NTCIP 1202 Amendment 1, a User Comment Draft, was incorporated into 1202v02, and was not advanced further.

NTCIP 1202 v02.10. June 2001 – Accepted as a User Comment Draft by the Joint Committee on the NTCIP. February 2002 – NTCIP Standards Bulletin B0068 referred v02.13 for user review and comment.

NTCIP 1202 v02.16. October 2002 – Accepted as a Recommended Standard by the Joint Committee on the NTCIP. April 2004 – NTCIP Standards Bulletin B0091 referred v02.18 for balloting. Approved by AASHTO in November 2004, approved by ITE in March 2005, and approved by NEMA in November 2004.

NTCIP 1202:2005 v02.19. November 2005 – Edited document for publication. By the terms of MOU on CTPA article 1.2, the ownership of version 02 was assigned to AASHTO, ITE, and NEMA because the preexisting work was revised by more than 50%.

NTCIP 1202 v03 was developed to reflect lessons learned, to update the document to the new documentation formats, and to add new features such as support for a connected vehicle interface. NTCIP 1202 v03 also follows an established systems engineering approach. Several new sections were added to relate user needs identified in a concept of operations, functional requirements, interface specifications and a requirements traceability matrix to the existing sections.

As NTCIP 1202 v03 was about to be published and distributed, a user provided proposed clarifications/corrections associated with experience in implementing the Flashing Yellow Arrow (FYA) functionality. The clarifications/corrections constitute the FYA errata, and is published as NTCIP 1202 v03A in May 2019.

The NTCIP 1202 v03B Amendment was published in May 2023 to address an urgent need to fix errors, clarify definitions, and provide additional guidance for traffic signal controllers to support the SAE J2735 SPaT Message in response to guidance detailed in Connected Transportation Interoperability (CTI) 4501, Connected Intersections (CI) Implementation Guide.

NTCIP 1202 v04 to be published in 2024.

Compatibility of Versions

To distinguish NTCIP 1202 v04 (as published) from previous drafts, NTCIP 1202 v04 also includes NTCIP 1202 v04.00a on each page header. All NTCIP Standards Publications have a major and minor version number for configuration management. The version number SYNTAX is "v00.00a," with the major version number before the period, and the minor version number and edition letter (if any) after the period.

The MIB associated with NTCIP 1202 v04 (as published) is **tbd**.

NTCIP 1202 v04 is designated, and should be cited as, NTCIP 1202 v04. Anyone using NTCIP 1202 v04 should seek information about the version number that is of interest to them in any given circumstance. The PRL, RTM and the MIB should all reference the version number of the standards publication that was the source of the excerpted material.

Note: Users of the Test Procedure Generator (TPG) should enter Standard Number 1202, Major Version Number 04, Minor Version Number 0, and browse for the TPG-enabled version of NTCIP 1202 v04.

Compliant systems based on later, or higher, version numbers MAY NOT be compatible with compliant systems based on earlier, or lower, version numbers. Anyone using NTCIP 1202 v04 should also consult NTCIP **8004 v02** for specific guidelines on compatibility.

TABLE OF CONTENTS

Note: The following Contents listing includes seven heading levels (for annexes) to permit TPG evaluation.

Section 1 General [Informative]	1
1.1 Scope	1
1.2 References.....	2
1.2.1 Normative References	2
1.2.2 Other References	2
1.2.3 Contact Information	3
1.2.3.1 Architecture Reference for Cooperative and Intelligent Transportation	3
1.2.3.2 ATC Standards	3
1.2.3.3 Caltrans Standards	3
1.2.3.4 Internet Engineering Task Force (IETF) Documents.....	3
1.2.3.5 NEMA Standards	4
1.2.3.6 NTCIP Standards	4
1.2.3.7 SAE International Standards	4
1.3 General Statements	4
1.4 Terms	4
1.5 Abbreviations	13
Section 2 Concept of Operations [Normative]	15
2.1 Tutorial [Informative]	15
2.2 Current Situation and Problem Statement [Informative]	16
2.3 Reference Physical Architecture [Informative].....	17
2.3.1 ASC Characteristics – Cabinet Specifications	19
2.3.2 ASC Characteristics – Controller Types.....	20
2.3.3 ASC Characteristics – Connected Vehicle Interface.....	21
2.3.4 ASC Characteristics – Interface with Other Roadside Devices/Processes	24
2.4 Architectural Needs.....	25
2.4.1 Provide Live Data	25
2.4.2 Provide Pre-Defined Data Blocks.....	25
2.4.3 Provide for Log Data Local Storage and Retrieval.....	26
2.4.4 Provide for Database Management	26
2.4.5 Condition-based Exception Reporting.....	26
2.5 Features	26
2.5.1 Manage the ASC Configuration	26
2.5.1.1 Manage Device Identity	27
2.5.1.2 Manage Communications.....	27
2.5.1.3 Manage Cabinet Environment	27
2.5.1.4 Monitor Power.....	27
2.5.1.5 Retrieve Operational Performance Data	27
2.5.1.6 Manage Auxiliary External Inputs/Outputs	27
2.5.1.7 Manage Database	28
2.5.1.8 Manage Peer-to-Peer with Other Devices.....	28
2.5.1.9 Manage Signal Monitoring Unit Information	28
2.5.1.10 Manage Interface with External Detectors	28
2.5.1.11 Manage ASC Clock	28
2.5.1.12 Manage External Control Local Application State	28
2.5.2 Manage Signal Operations.....	28
2.5.2.1 Manage Signal Configuration	29

2.5.2.1.1	Manage Controller Startup Functions	29
2.5.2.1.2	Manage Phase Configurations	29
2.5.2.1.3	Manage Coordination Configurations	29
2.5.2.1.4	Manage Timing Patterns	29
2.5.2.1.5	Manage Splits Configurations	29
2.5.2.1.6	Manage Ring Configurations	29
2.5.2.1.7	Manage Channel Configurations	30
2.5.2.1.8	Manage Overlap Configurations	30
2.5.2.1.9	Manage Preempt Configurations	30
2.5.2.1.10	Manage Timing Pattern Scheduler	30
2.5.2.1.11	Manage Action Scheduler	30
2.5.2.1.12	Manage I/O Mapping	30
2.5.2.1.13	Manage Intra-Cabinet Communications Configuration	30
2.5.2.1.14	Manage Pedestrian Support	31
2.5.2.2	Monitor Signal Operations Status	31
2.5.2.2.1	Determine Controller Health	31
2.5.2.2.2	Determine Mode of Operation	31
2.5.2.2.3	Monitor Signal Indication	32
2.5.2.2.4	Monitor Phase Status	32
2.5.2.2.5	Monitor Ring Status	32
2.5.2.2.6	Monitor Channel Status	32
2.5.2.2.7	Monitor Overlap Status	32
2.5.2.2.8	Monitor Preempt Status	32
2.5.2.2.9	Monitor Special Function Outputs	33
2.5.2.2.10	Monitor Timebase Action Status	33
2.5.2.2.11	Monitor Intra-Cabinet Communications Configuration	33
2.5.2.2.12	Monitor Peer-to-Peer State	33
2.5.2.2.13	Monitor Signal Monitoring Unit	33
2.5.2.3	Control Signal Operations	33
2.5.2.3.1	Control ASC-wide General Operations	34
2.5.2.3.2	Command Timing Pattern	34
2.5.2.3.3	Phase Requests	34
2.5.2.3.4	Activate Preempt	34
2.5.2.3.5	Control Ring Operations	34
2.5.2.3.6	Activate Special Function Output	34
2.5.2.3.7	Control Frame 40	34
2.5.2.3.8	Activate Action Plan	34
2.5.2.3.9	Remote Manual Control	34
2.5.3	Manage Detectors	35
2.5.3.1	Manage Detector Configuration	35
2.5.3.2	Monitor Detector Status	35
2.5.3.3	Monitor Detector Health	35
2.5.3.4	Control Detectors	35
2.5.3.5	Manage Detector Data	35
2.5.3.6	Monitor Detector Data from External Detectors	35
2.5.4	Manage Connected Vehicles Interface	35
2.5.4.1	Connected Vehicle Interface: Management Station – ASC Interface	36
2.5.4.1.1	Manage CV Application Process Interface	36
2.5.4.1.2	Manage CV Application Process Interface Watchdog	36
2.5.4.1.3	Manage Signal Phase and Timing Data	36
2.5.4.1.4	Manage Assured Green Period	36
2.5.4.2	Connected Vehicle Interface: ASC – CV Application Process Interface	37
2.5.4.2.1	Exchange Current and Next Movement Information	37
2.5.4.2.2	Exchange Next Occurrence of a Movement	37
2.5.4.2.3	Exchange Presence of Connected Devices	37
2.5.4.2.4	Exchange Roadway Geometrics Information	37

2.5.4.3	ASC – ECLA Interface.....	38
2.5.5	Backward Compatibility Features.....	38
2.6	Security.....	38
2.6.1	Manage Authentication.....	38
2.6.2	Manage Accessibility.....	38
2.6.3	Manage Users.....	38
2.6.4	Log User Access.....	38
2.6.5	Manage ASC Interface Security.....	39
2.6.5.1	Manage Security for the ASC to RSU Interface.....	39
2.6.5.2	Manage Security for Other ASC Interfaces.....	39
2.7	Operational Policies and Constraints.....	39
2.8	Relationship to the ITS National Architecture [Informative].....	39
Section 3 Functional Requirements [Normative].....		42
3.1	Tutorial [Informative].....	42
3.2	Scope Of The Interface [Informative].....	43
3.3	Protocol Requirements List (PRL).....	43
3.3.1	Notation [Informative].....	43
3.3.1.1	Conformance Symbols.....	43
3.3.1.2	Conditional Status Notation.....	44
3.3.1.3	Support Column Symbols.....	45
3.3.2	Instructions for Completing the PRL [Informative].....	45
3.3.2.1	Conformance Definition.....	45
3.3.3	Protocol Requirements List (PRL) Table.....	46
3.4	Architectural Requirements.....	91
3.4.1	Support Basic Communications Requirements.....	91
3.4.1.1	Retrieve Data.....	91
3.4.1.2	Deliver Data.....	91
3.4.1.3	Explore Data.....	91
3.4.1.4	SNMP Requirements.....	91
3.4.1.4.1	Monitor SNMP Information.....	91
3.4.2	Manage Data Blocks Requirements.....	91
3.4.2.1	Store Pre-defined Compressed Data Blocks.....	91
3.4.3	Support Logged Data Requirements.....	92
3.4.4	Support Database Management.....	92
3.4.5	Support Condition-based Exception Reporting.....	92
3.5	Data Exchange and Operational Environment Requirements.....	92
3.5.1	ASC Configuration Management Requirements.....	92
3.5.1.1	Manage ASC Information Requirements.....	92
3.5.1.1.1	Configure ASC Location.....	92
3.5.1.1.2	Configure ASC Location - Antenna Offset.....	93
3.5.1.1.3	Determine Supported Standards.....	93
3.5.1.2	Manage Communications Requirements.....	93
3.5.1.2.1	Configure Communications Requirements.....	93
3.5.1.3	Manage Cabinet Environment Requirements.....	94
3.5.1.3.1	Configure ATC Cabinet Device LEDs.....	94
3.5.1.4	Monitor Power Requirements.....	94
3.5.1.4.1	Determine Power Source.....	94
3.5.1.5	Manage Operational Performance Data Requirements.....	94
3.5.1.6	Manage Auxiliary External Inputs/Outputs Requirements.....	94
3.5.1.7	Manage Database Operations.....	95
3.5.1.7.1	Determine Unique Deployment Configuration Identifier.....	95
3.5.1.7.2	Determine Configuration Identifier Parameter Content.....	95

3.5.1.7.3	Configure Parameters for Creation of an Alternate Device Configuration Identifier	95
3.5.1.8	Manage Peer-to-Peer Connection Requirements	95
3.5.1.8.1	Configure Peer-to-Peer Identifier Description	95
3.5.1.8.2	Configure Peer-to-Peer Connection Target	95
3.5.1.8.3	Configure Peer-to-Peer Connection Trigger Conditions	96
3.5.1.8.4	Configure Peer-to-Peer Connection Action	96
3.5.1.8.5	Determine Maximum Number of Peer-to-Peer Connections	96
3.5.1.9	Manage Signal Monitoring Unit Interface Requirements	96
3.5.1.9.1	Enable/Disable Monitoring of the Flash State from the Signal Monitoring Unit	96
3.5.1.9.2	Enable/Disable Monitoring of Channel Voltage from the Signal Monitoring Unit	96
3.5.1.9.3	Enable/Disable Monitoring of Channel Current from the Signal Monitoring Unit	96
3.5.1.10	Manage Interface with External Detectors Requirements	96
3.5.1.11	Manage ASC Clock Requirements	96
3.5.1.12	Manage External Control Local Application State Requirements	97
3.5.1.12.1	Enable / Disable ECLA	97
3.5.1.12.2	Configure ECLA Communications Port	97
3.5.1.12.3	Configure ECLA Polling Period	97
3.5.2	Manage Signal Operations Management Requirements	97
3.5.2.1	Manage Signal Configuration Requirements	97
3.5.2.1.1	Manage Unit Configuration Requirements	97
3.5.2.1.2	Manage Phase Configuration Requirements	98
3.5.2.1.3	Manage Coordination Configuration Requirements	105
3.5.2.1.4	Manage Phase-Based Timing Patterns Requirements	107
3.5.2.1.5	Manage Splits Configuration Requirements	108
3.5.2.1.6	Manage Ring Configuration Requirements	110
3.5.2.1.7	Manage Channel Configuration Requirements	110
3.5.2.1.8	Manage Overlap Configuration Requirements	111
3.5.2.1.9	Manage Preempt Configuration Requirements	115
3.5.2.1.10	Manage ASC Scheduler Requirements	120
3.5.2.1.11	Manage Action Scheduler Requirements	120
3.5.2.1.12	Manage I/O Mapping Requirements	121
3.5.2.1.13	Manage Intra-Cabinet Communications Requirements	124
3.5.2.1.14	Manage ADA Support Requirements	124
3.5.2.2	Monitor Signal Operations Requirements	125
3.5.2.2.1	Determine Controller Health Requirements	125
3.5.2.2.2	Retrieve Mode of Operation Requirements	129
3.5.2.2.3	Monitor Signal Indication Requirements	132
3.5.2.2.4	Monitor Phase Status Requirements	133
3.5.2.2.5	Retrieve Current Ring Requirements	133
3.5.2.2.6	Retrieve Current Channel Status Requirements	134
3.5.2.2.7	Retrieve Current Overlap Status Requirements	134
3.5.2.2.8	Retrieve Current Preempt Status Requirements	135
3.5.2.2.9	Retrieve Special Function Outputs Requirements	136
3.5.2.2.10	Monitor Timebase Action Status Requirements	136
3.5.2.2.11	Monitor Intra-Cabinet Communications Requirements	136
3.5.2.2.12	Monitor Peer-to-Peer Connection Requirements	137
3.5.2.2.13	Monitor Signal Monitoring Unit Requirements	137
3.5.2.3	Manage Signal Operations Control Requirements	138
3.5.2.3.1	Control ASC Function Requirements	138
3.5.2.3.2	Command Timing Pattern Requirements	139
3.5.2.3.3	Control Phases Requirements	139
3.5.2.3.4	Control Preempt Requirements	140

	3.5.2.3.5	Control Ring Requirements.....	140
	3.5.2.3.6	Special Functions Control Requirements	141
	3.5.2.3.7	Control Frame 40 Requirements	142
	3.5.2.3.8	Activate Action Plan	142
	3.5.2.3.9	Remote Manual Control Requirements	142
3.5.3		Detector Management Requirements	142
	3.5.3.1	Manage Detector Configuration Requirements	142
	3.5.3.1.1	Configure Detectors Requirements	143
	3.5.3.1.2	Configure Pedestrian Detectors Requirements	145
	3.5.3.1.3	Retrieve Detector Configuration Requirements	146
	3.5.3.2	Retrieve Detector Status Requirements	146
	3.5.3.2.1	Determine Detector Data Active Detectors	146
	3.5.3.2.2	Monitor Active Vehicle Detector Status	146
	3.5.3.2.3	Determine Pedestrian Detector Data Active Detectors	146
	3.5.3.2.4	Monitor Active Pedestrian Detector Status	146
	3.5.3.3	Retrieve Detector Health Requirements.....	147
	3.5.3.3.1	Retrieve Vehicle Detector Health Requirements	147
	3.5.3.3.2	Retrieve Vehicle Loop Detector Health Requirements	147
	3.5.3.3.3	Retrieve Pedestrian Detector Health Requirements.....	148
	3.5.3.4	Control Detector Requirements	149
	3.5.3.4.1	Control Vehicle Detector Reset	149
	3.5.3.4.2	Control Pedestrian Detector Reset	149
	3.5.3.4.3	Control Vehicle Detector Actuation	149
	3.5.3.4.4	Control Pedestrian Detector Actuation	149
	3.5.3.5	Manage Detector Data Collection Requirements	149
3.5.4		Connected Vehicles Interface Management	149
	3.5.4.1	Manage Management Station – ASC Interface Requirements	149
	3.5.4.1.1	Manage CV Application Process Interface Requirements.....	150
	3.5.4.1.2	Manage CV Application Process Interface Watchdog Requirements.....	150
	3.5.4.1.3	Manage Signal Phase and Timing Requirements	150
	3.5.4.1.4	Manage Assured Green Period Requirements.....	160
	3.5.4.2	ASC – CV Application Process Interface Requirements	160
	3.5.4.2.1	Exchange Current and Next Movement Information Requirements.....	161
	3.5.4.2.2	Exchange Next Occurrence of a Movement Requirements	164
	3.5.4.2.3	Exchange Presence of Connected Device Requirements.....	165
	3.5.4.2.4	Exchange Roadway Geometrics Information Requirements...	166
	3.5.4.3	ASC – ECLA Interface Requirements	166
	3.5.4.3.1	Retrieve Current Movement State from an ECLA.....	166
	3.5.4.3.2	Retrieve Current Minimum End Time from an ECLA.....	166
	3.5.4.3.3	Retrieve Current Maximum End Time from an ECLA.....	167
	3.5.4.3.4	Retrieve Current Likely End Time from an ECLA	167
	3.5.4.3.5	Retrieve Current Likely End Time Confidence from an ECLA.	167
	3.5.4.3.6	Retrieve Next Movement State from an ECLA	167
	3.5.4.3.7	Retrieve Next Minimum End Time from an ECLA	167
	3.5.4.3.8	Retrieve Next Maximum End Time from an ECLA	167
	3.5.4.3.9	Retrieve Next Movement Start Time from an ECLA	168
3.5.5		Backward Compatibility Requirements	168
3.6		Supplemental Non-communications Requirements	168
	3.6.1	Response Time for Requests.....	168
	3.6.2	Atomic Operations.....	168
	3.6.3	Supplemental Requirements for Event Logging	168
	3.6.3.1	Detect Events Related to an Atomic Object	168
	3.6.3.2	Reporting an Atomic Object.....	169
	3.6.4	Condition-based Maximum Transmission Start Time	169

3.6.5 Signal Phase and Timing Data Performance Requirements 169
3.6.5.1 SPaT Maximum Transmission Start Time 169
3.6.5.2 Movement Time Point Minimum Transmission Rate 169
3.6.5.3 SPaT Maximum Transmission Rate 169
3.6.5.4 SPaT Time Accuracy 169

LIST OF FIGURES

Figure 1 Reference Physical Architecture - ASC System 18
Figure 2 Controller Assembly 20
Figure 3 Connected Intersection Logical Processes 22
Figure 4 ASC - Connected Vehicle System Context Diagram 23
Figure 5 Physical Architecture 1 23
Figure 6 Physical Architecture 2 24
Figure 7 Roadside Process/Devices Interface 25

LIST OF TABLES

Table 1 Conformance Symbols 43
Table 2 Conditional Status Notation 44
Table 3 Predicate Mapping to NTCIP 1202 v04 Section 44
Table 4 Support Column Entries 45
Table 5 Protocol Requirements List (PRL) 48
Table 6 Field I/O Devices Supported 121

<This page is intentionally left blank.>

Section 1 General [Informative]

1.1 Scope

NTCIP 1202 v04 specifies the logical interface between an Actuated Signal Controller (ASC) and the host systems that control them; and the logical interface between an ASC and other roadside devices or processes at the intersection, such as a signal monitoring unit (SMU) in the transportation cabinet, a connected vehicle (CV) application process, or external control local application (ECLA). NTCIP 1202 v04 describes the supported ASC functionality in terms of user needs and requirements; however, the nature of the interfaces is determined in part by the operational nature of the devices being controlled, and therefore NTCIP 1202 v04 touches on such operational issues on occasion.

Prior to the development of NTCIP 1202, there were no standards defining how ASCs communicate with host systems or roadside devices/processes. As a result, each manufacturer has developed its own protocol to meet its own particular needs. This approach has resulted in systems that are not interchangeable or interoperable. If an agency wishes to use either a central management system or additional ASC from a different vendor, the agency encounters significant systems integration challenges, requiring additional resources to address. These additional resource requirements inhibit information sharing within and between various potential users of the data and prevent vendor independence. Without manufacturer independence, resource requirements further increase because of a lack of a competitive market.

These problems have not been limited to traffic signal controllers. Many other devices also need to exchange information. In surface transportation, examples include dynamic message signs, bus priority sensors, weather, and environmental monitoring, etc.

To address these problems, NTCIP is developing a family of open standards for communications between field devices and central management systems. NTCIP 1202 v04 is part of that larger family and is designed to define an interoperable and interchangeable interface between a transportation management system and an ASC, while still allowing for extensions beyond NTCIP 1202 v04 to allow for new functions as needed; and between an ASC and other roadside devices/processes. This approach is expected to support the deployment of ASC from one or more vendors in a consistent and resource-efficient way.

NTCIP 1202 v04 standardizes the communications interface by identifying the various operational needs of the users (Section 2) and subsequently identifying the necessary requirements (Section 3) that support each need. NTCIP standardized communications interface used to fulfill these requirements are identified by dialogs (Section 4) and related data concepts (Section 5) that support each requirement. Traceability among the various sections is defined by the Protocol Requirements List (Section 3.3) and the Requirements Traceability Matrix (Annex A). Conformance requirements for NTCIP 1202 v04 are provided in Section 3.3. NTCIP 1202 v04 only addresses a subset of the requirements needed for procurement. It does not address requirements related to the performance of the traffic detectors (e.g., accuracy, the supported detection range, the time it takes to detect conditions, etc.), hardware components, mounting details, etc.

Previous versions of NTCIP 1202 addressed only ASCs that employ vehicle or pedestrian detectors to activate a particular phase – the scope did not include pre-timed, or fixed-time signal controllers that cycle through phases regardless of the number of vehicles or pedestrians present. ASCs included both fully actuated traffic signals, where all phases are actuated, and phases are skipped if no vehicles or pedestrians are detected; and semi-actuated traffic signals, where at least one phase is guaranteed to be served regardless of whether pedestrians or vehicles are detected. For the NTCIP 1202 purposes,

controllers that allow different phases to be active (or skipped) at any point in time phase are known as phase-based controllers.

Beginning with NTCIP 1202 v03, the scope was expanded to standardize the communications interface between an ASC and a CV Roadside Process, which may be located inside an RSU. An RSU is any connected vehicle field device that is used to broadcast messages to, and receive messages from, nearby vehicles using Vehicle-to-Everything (V2X) communications. V2X communications includes Dedicated Short-Range Communications (DSRC), and Cellular Vehicle-To-Everything (C-V2X).

An implementation of NTCIP 1202 requires lower-level services to structure, encode, and exchange the data concepts defined by NTCIP 1202. NTCIP 1202 assumes that the data concepts are exchanged by one of the protocols defined in NTCIP 2301.

1.2 References

1.2.1 Normative References

Normative references contain provisions that, through reference in this text, constitute provisions of NTCIP 1202 v04. Other references in NTCIP 1202 v04 might provide a complete understanding or provide additional information. At the time of publication, the editions indicated were valid. All standards are subject to revision, and parties to agreements based on NTCIP 1202 v04 are encouraged to investigate the possibility of applying the most recent editions of the standards listed.

Identifier	Title
ATC 5301 v02	Advanced Transportation Controller (ATC) Cabinet Standard Version 02, v02.02, AASHTO / ITE / NEMA, published March 18, 2019.
IETF RFC 1907	Management Information Base for Version 2 of the Simple Network Management Protocol (SNMPv2), January 1996.
NEMA TS 1-1989 (R2020)	NEMA Standards Publication TS 1-1989 (R1994, R2000, R2005, R2020), Traffic Control Systems. (Not Recommended for New Designs)
NEMA TS 2-2021	NEMA Standards Publication TS 2-2021, Traffic Controller Assemblies with NTCIP Requirements Version 03.08, NEMA, published 2021.
SAE J2735	V2X Communications Message Set Dictionary, SAE International, published September 2023.

1.2.2 Other References

The following documents and standards may provide the reader with a better understanding of the entire protocol and the relations between all parts of the protocol. However, these documents do not contain direct provisions that are required by NTCIP 1202 v04. At the time of publication, the editions indicated were valid. All standards are subject to revision, and parties to agreements based on NTCIP 1202 v04 are encouraged to investigate the possibility of applying the most recent editions of the standard listed.

Identifier	Title
ATC 5201 API v06	Advanced Transportation Controller (ATC) Standard Version v06A, v06A.37, AASHTO / ITE / NEMA, published July 29, 2020.
ATC 5401 v02b	Application Programming Interface (API) Standard for the Advanced Transportation Controller (ATC) v02B, v02B.45, published February 16, 2023.
CTI 4001	Connected Transportation Interoperability 4001 - Roadside Unit (RSU) Standard, September 2022, v01.01. https://www.ite.org/technical-resources/standards/rsu-standardization/
CTI 4501	Connected Transportation Interoperability 4501 – Connected Intersections (CI) Implementation Guide, June 2022, v01.01. https://www.ite.org/technical-resources/standards/connected-intersections/
Caltrans TEES 2020	Caltrans Transportation Electrical Equipment Specifications (TEES), 2020.

Identifier	Title
IEEE Std 100-2000	The Authoritative Dictionary of IEEE Standards Terms, IEEE, December 11, 2000.
Manual of Uniform Traffic Control Devices	Manual of Uniform Traffic Control Devices, FHWA, 11 th Edition, December 2023.
Multimodal Intelligent Traffic Signal System	Multi-Modal Intelligent Traffic Signal System – Phase II: System Development, Deployment and Field Test, Final Report, Connected Vehicle Pooled Fund Study, September 2016. https://engineering.virginia.edu/sites/default/files/common/Centers/CTS/CVPFS/projects/53 MMITSS Phase 2 - Final Report – FINAL 09252016-compressed.pdf
NTCIP 1209	Object Definitions for Transportation Sensor Systems (TSS) Version 02, AASHTO / ITE / NEMA, published May 2014.
Preemption of Traffic Signals Near RR Grade Crossings, 2006	The Preemption of Traffic Signals Near RR Grade Crossings, an ITE Recommended Practice, Institute of Transportation Engineers, 2006.
Signal Timing Manual	Signal Timing Manual - Second Edition, National Academies of Sciences, Engineering, and Medicine, 2015.
U.S. Architecture Reference for Cooperative and Intelligent Transportation (ARC-IT)	Architecture Reference for Cooperative and Intelligent Transportation (ARC-IT), USDOT, Version 9.2. http://arc-it.net/
V2I Hub Interface Control Document	Integrated Vehicle-to-Infrastructure Prototype (IVP), V2I Hub Interface Control Document (ICD) - Final Report March 2017, FHWA JPO.

1.2.3 Contact Information

1.2.3.1 Architecture Reference for Cooperative and Intelligent Transportation

The Architecture Reference for Cooperative and Intelligent Transportation (ARC-IT) may be viewed at:

<http://arc-it.net/>

ARC-IT is also known as US National ITS Architecture and combines the US National ITS Architecture and the Connected Vehicle Reference Implementation Architecture (CVRIA).

1.2.3.2 ATC Standards

The Advanced Transportation Controller (ATC) Family of Standards may be view at:

<https://www.ite.org/technical-resources/standards/>

1.2.3.3 Caltrans Standards

Caltrans' Transportation Electrical Equipment Specifications (TEES) may be viewed at:

<https://dot.ca.gov/programs/traffic-operations/tees>

1.2.3.4 Internet Engineering Task Force (IETF) Documents

Obtain Request for Comment (RFC) electronic documents from several repositories on the World Wide Web, or by "anonymous" File Transfer Protocol (FTP) with several hosts. Browse or FTP to:

www.rfc-editor.org
www.rfc-editor.org/repositories.html
for FTP sites, read <ftp://ftp.isi.edu/in-notes/rfc-retrieval.txt>

1.2.3.5 NEMA Standards

Copies of NEMA standards may be obtained from:

National Electrical Manufacturers Association
1300 N.17th Street, Suite 900
Rosslyn, Virginia 22209-3801
www.nema.org

1.2.3.6 NTCIP Standards

Copies of NTCIP standards may be obtained from:

NTCIP Coordinator
National Electrical Manufacturers Association
1300 N.17th Street, Suite 900
Rosslyn, Virginia 22209-3801
www.ntcip.org
e-mail: ntcip@nema.org

Draft amendments, which are under discussion by the relevant NTCIP Working Group, and amendments recommended by the NTCIP Joint Committee are available.

1.2.3.7 SAE International Standards

Copies of SAE International standards may be obtained from:

SAE International
400 Commonwealth Drive
Warrendale, PA 15096
www.sae.org

1.3 General Statements

<In the opinion of the responsible NTCIP working group, Section 1.3 does not apply in the context of NTCIP 1202 v04.>

1.4 Terms

For the purposes of NTCIP 1202 v04, the following terms, definitions, acronyms, and abbreviations apply. Meteorological terms not defined in this section are in accordance with their definitions in the Glossary of Meteorology. Electrical and electronic terms not defined here are used in accordance with their definitions in IEEE Std 100-2000. English words not defined here or in IEEE Std 100-2000 are used in accordance with their definitions in Webster's New Collegiate Dictionary.

Term	Definition
Actuated Signal Controller (ASC)	Any traffic signal controller, regardless if it is a phase-based controller or interval-based controller.
actuation	The operation of any type of detector.

Term	Definition
advanced preemption time	The period of time between the minimum warning time needed for railroad operations and the maximum preemption time required for highway traffic signal operations.
automatic flash	Automatic programmed flash mode not caused by manual switch activation or fault condition or startup.
auxiliary function	A control that may activate auxiliary functions or outputs in an actuated controller unit.
backup mode	Control by local TBC or Interconnect based on absence of master or central command.
barrier	<p>A barrier (compatibility line) is a reference point in the preferred sequence of a multi-ring CU at which all rings are interlocked.</p> <p>Note: Barriers assure there is no concurrent selection and timing of conflicting phases for traffic movement in different rings. All rings cross the barrier simultaneously for the selection and timing of phases on the other side.</p>
Basic Safety Message (BSM)	<p>The Basic Safety Message (BSM) is used in a variety of applications to exchange safety data regarding vehicle state.</p> <p>Source: SAE J2735_202309</p>
Bus Rapid Transit (BRT)	Bus rapid transit (BRT) refers to a system of buses that operate more like a conventional rail system than the traditional local buses. BRT lines can operate in mixed traffic like other bus routes, in reserved bus lanes, or even in segregated rights of way. For the purpose of this document, BRT refers to reserved bus lanes or segregated lanes arriving at a signalized intersection.
call	A registration of a demand for right-of-way by traffic (vehicles or pedestrians) to a controller unit.
call, serviceable conflicting	<p>A call which:</p> <ol style="list-style-type: none"> Occurs on a conflicting phase not having the right-of-way at the time the call is placed. Occurs on a conflicting phase which is capable of responding to a call. When occurring on a conflicting phase operating in an occupancy mode, remains present until given its right-of-way.
channel	Three circuits of a Monitor Device wired to monitor the green, yellow, and red outputs of the associated load switch position in the Terminal & Facilities. Channel 1 is assumed to monitor Load Switch 1, etc.
check	An output from a controller unit that indicates the existence of unanswered call(s).
clear track change interval	The yellow change interval following the clear track green interval and preceding the railroad hold intervals. A red clearance interval shall follow the clear track change interval if such an interval follows the normal yellow change interval. (Preemption of Traffic Signals Near Railroad Crossings - ITE, 2006)
computed lane	A lane that has a similar geometry and attributes of another lane.

Term	Definition
concurrency group	<p>A group of phases which describes possible timing combinations.</p> <p>Note: A phase within the group is required to be able to time concurrently with any other phase from another ring contained in the group. For example, in the typical dual-ring eight phase design, phases 1, 2, 5, and 6 form one concurrency group, and phases 3, 4, 7, and 8 form another concurrency group.</p>
concurrent timing	<p>A mode of controller unit operation whereby a traffic phase can be selected and timed simultaneously and independently with another traffic phase.</p>
connected device	<p>A mobile device, such as a vehicle or smartphone, equipped to broadcast, transmit or receive messages using V2X communications.</p>
Connected Vehicle Roadside Process	<p>A logical, functional process consisting of sub-processes that support the connected vehicle environment. From the context of an ASC, the relevant sub-processes include running intersection CV applications, broadcasting the SPAT and MAP messages to connected devices, and processing Basic Safety Messages (BSMs) and Personal Safety Messages (PSMs) received from connected devices by the CV Application Process. Physically, this may be a roadside unit (RSU).</p>
Controller Assembly (CA)	<p>A complete electrical device mounted in a cabinet for controlling the operation of a traffic control signal display(s).</p>
Controller Unit (CU)	<p>A controller unit is that portion of a controller assembly that is devoted to the selection and timing of signal displays.</p>
Coordinated Universal Time (UTC)	<p>UTC is the time standard commonly used across the world. The world's timing centers have agreed to keep their time scales closely synchronized – or coordinated. This 24-hour time standard is kept using highly precise atomic clocks combined with the Earth's rotation. UTC is similar to Greenwich Mean Time, but while UTC is a time standard, GMT refers to a time zone (similar to Eastern Standard Time). UTC never changes to account for daylight saving time.</p>
coordination	<p>The control of controller units in a manner to provide a relationship between specific green indications at adjacent intersections in accordance with a time schedule to permit continuous operation of groups of vehicles along the street at a planned speed.</p>
coordinator	<p>A device or program/routine which provides coordination.</p>
cycle	<p>The total time to complete one sequence of signalization around an intersection. In an actuated controller unit, a complete cycle is dependent on the presence of calls on all phases.</p> <p>Note: In a pre-timed controller unit, it is a complete sequence of signal indications.</p>
cycle length	<p>The time period in seconds required for one complete cycle.</p>

Term	Definition
Detector, pedestrian	<p>Pedestrian detectors may be pushbuttons or passive detection devices. Passive detection devices register the presence of a pedestrian in a position indicative of a desire to cross, without requiring the pedestrian to push a button. Some passive detection devices are capable of tracking the progress of a pedestrian as the pedestrian crosses the roadway for the purpose of extending or shortening the duration of certain pedestrian timing intervals.</p> <p>Source: Manual of Uniform Traffic Control Devices, FHWA, December 2023</p>
detector, system	Any type of vehicle detector used to obtain representative traffic flow information.
detector, vehicle	A detector that is responsive to operation by or the presence of a vehicle.
dial	The cycle timing reference or coordination input activating same. Dial is also frequently used to describe the cycle.
display map	A graphic display of the street system being controlled showing the status of the signal indications and the status of the traffic flow conditions.
dual entry	<p>Dual entry is a mode of operation (in a multi-ring CU) in which one phase in each ring is required to be in service.</p> <p>Note: If a call does not exist in a ring when it crosses the barrier, a phase is selected in that ring to be activated by the CU in a predetermined manner.</p>
dwell	The interval portion of a phase when present timing requirements have been completed.
dynamic timing pattern	A transient timing plan to be used for the next cycle only.
external control location application	An application that asserts a higher-level control over the traffic signal controller.
enabled lanes (list)	A sequence of lane identifiers for lanes that are identified to be enabled (active) and can be used by the appropriate travelers at the current time.
first coordinated phase	The coordinated phase which occurs first within the concurrent group of phases containing the coordinated phase(s) when there are constant calls on all phases.
Flash	An operation where one section in each vehicle signal (yellow or red) is alternately on and off with a one second cycle time and a 50 percent duty cycle.
fault monitor state	<p>Internal CU diagnostics have determined that the CU device is not in a safe operational state.</p> <p>Note: An output may be asserted to indicate this condition.</p>

Term	Definition
force off	<p>A command to force the termination of the green indication in the actuated mode or Walk Hold in the nonactuated mode of the associated phase.</p> <p>Note: Termination is subject to the presence of a serviceable conflicting call. The Force Off function is not effective during the timing of the Initial, Walk, or Pedestrian Clearance. The Force Off is only effective as long as the condition is sustained. If a phase-specific Force Off is applied, the Force Off does not prevent the start of green for that phase.</p>
Free	Operation without coordination control from any source.
gap reduction	A feature whereby the Unit Extension or allowed time spacing between successive vehicle actuations on the phase displaying the green in the extensible portion of the Green indication is reduced.
Group	Any portion of a traffic control network (system) that can be controlled by a common set of timing patterns.
Hold	A command that retains the existing Green indication.
Hold-on line	A signal to an intersection controller commanding it to remain under computer control.
interchangeability	<p>A condition which exists when two or more items possess such functional and physical characteristics as to be equivalent in performance and durability and are capable of being exchanged one for the other without alteration of the items themselves, or adjoining items, except for adjustment, and without selection for fit and performance.</p> <p>Source: National Telecommunications and Information Administration, U.S. Department of Commerce</p>
Interconnect	A means of remotely controlling some or all of the functions of a traffic signal.
interoperability	<p>The ability of two or more systems or components to exchange information and use the information that has been exchanged</p> <p>Source: IEEE Std. 610.12-1990: IEEE Standard Glossary of Software Engineering Terminology</p>
intersection status	The knowledge of whether a controlled intersection is on-line and which mode it is currently operating in.
indication	The part or parts of the signal cycle during which signal indication displays do not change.
Interval-based controller	A traffic signal controller implementing a sequence of defined, discrete steps (i.e., an interval), each interval driving their associated signal indications, in a repeating cycle according to the timing constraints programmed into the device. Note that some step sequences may be displayed or skipped in response to traffic conditions.

Term	Definition
Light Rail Transit (LRT)	A metropolitan electric railway system characterized by its ability to operate single cars or short trains along exclusive rights-of-way at ground level, on aerial structures, in subways or, occasionally, in streets, and to board and discharge passengers at track or car-floor level. For the purpose of this document, LRT refers to exclusive rights-of-way lanes arriving at a signalized intersection.
load switch driver group	The set of three outputs which are used to drive load switch inputs to provide a Green, Yellow, or Red output condition for vehicle signals or Walk, Ped Clear, or Don't Walk output condition for pedestrian signals.
Malfunction Management Unit (MMU)	A device used to detect and respond to improper and conflicting signals and improper operating voltages in a traffic controller assembly.
Management Information Base (MIB)	A structured collection or database of related managed objects defined using Abstract Syntax Notation One (ASN.1). Source: NTCIP 8004 v02 and ISO/IEC 8824-1:2008 and ISO/IEC 8825-1:2008.
Manual Control Enable	An input to place calls on all actuated movements, stop CU timing in programmed variable intervals, and inhibit the operation of Interval Advance during all other intervals.
MAP message	The MAPData message is used to convey many types of geographic road information. At the current time, its primary use is to convey one or more intersection lane geometry maps within a single message. Source: SAE J2735_202309
maximum green	The maximum green time with a serviceable opposing actuation, which may start during the initial portion.
Movement	An action that is taken to traverse through an intersection, reflecting the user perspective and defined by the user type.
Multi-ring controller unit	A multi-ring CU contains two or more interlocked rings which are arranged to time in a preferred sequence and to allow concurrent timing of all rings, subject to barrier restraint.
Node point	A point defining the centerline of the pathway of a lane.
nonlocking memory	A mode of actuated-controller-unit operation which does not require the retention of a call for future utilization by the controller assembly.
Occupancy	A measurement of vehicle presence within a zone of detection, expressed in seconds of time a given point or area is occupied by a vehicle.
Off-line	A controller assembly not under the control of the normal control source.
Offset	The time relationship, expressed in seconds, between the starting point of the first coordinated phase Green and a system reference point. (See definition of First Coordinated Phase)

Term	Definition
omit, phase	A command that causes omission of a selected phase.
On-line	A controller assembly under the control of the normal control source.
Overlap	A Green display that allows traffic movement during the green indications of and clearance indications between two or more phases.
Passage time	The time allowed for a vehicle to travel at a selected speed from the detector to the stop line.
Pattern	<p>A unique set of coordination parameters (cycle value, split values, offset value, and either signal plan or phase sequence).</p> <p>Note: A phase-based timing pattern consists of a cycle length, offset, set of minimum green and maximum green values, force off (determined by splits in some cases), and phase sequence. It also includes specification of phase parameters for minimum or maximum vehicle recall, pedestrian recall, or phase omit.</p> <p>An interval-based timing pattern consists of a cycle length, offset, set of minimum and programmed interval duration values, and a signal plan sequence.</p>
Pedestrian clearance interval	The first clearance interval for the pedestrian signal following the pedestrian WALK indication.
Pedestrian recycle	A method of placing a recurring demand for pedestrian service on the movement when that movement is not in its Walk interval.
permissive	A time period, during which the CU is allowed to leave the coordinated phase(s) under coordination control to go to other phases.
Personal Safety Message (PSM)	<p>The Personal Safety Message (PSM) is used to broadcast safety data regarding the kinematic state of various types of Vulnerable Road Users (VRU), such as pedestrians, cyclists or road workers.</p> <p>Source: SAE J2735_202309</p>
phase	<p>A timing unit associated with the control of one or more movements. Phases are often assigned to vehicular and pedestrian movements.</p> <p>Source: Signal Timing Manual</p> <p>Note: unless otherwise noted, a phase may be assigned to a vehicular, transit vehicle, or bicycle movement.</p>
phase sequence	A predetermined order in which the phases of a cycle occur.
phase, active	The indicated phase is currently timing. A phase is always active if it is Green or Yellow (Walk or Pedestrian Clear for Pedestrian Phases). It is also active if it is timing Red Clearance. It may be considered active during Red Dwell.
phase, conflicting	Conflicting phases are two or more traffic phases which cause interfering traffic movements if operated concurrently.

Term	Definition
phase, nonconflicting	Nonconflicting phases are two or more traffic phases which do not cause interfering traffic movements if operated concurrently.
phase, pedestrian	A traffic phase allocated to pedestrian traffic which may provide a right-of-way pedestrian indication either concurrently with one or more vehicular phases, or to the exclusion of all vehicular phases.
phase, traffic	Those green, change and clearance intervals in a cycle assigned to any independent movement(s) of traffic.
phase, vehicular	A vehicular phase is a phase which is allocated to vehicular traffic movement as timed by the controller unit.
preempt dwell interval	The period of time when the track area is occupied by a tracked vehicle.
preemption	The transfer of the normal control of signals to a special signal control mode for the purpose of servicing railroad crossings, emergency vehicle passage, mass transit vehicle passage, and other special tasks, the control of which require terminating normal traffic control to provide the priority needs of the special task.
preemptor	A device or program/routine which provides preemption.
priority request	The information that describes a need for (signal) priority service based upon user-defined criteria (such as the number of minutes behind schedule, vehicle occupancy levels, vehicle class, etc.). Source: NTCIP 1211 v02.
progression	The act of various controller units providing specific green indications in accordance with a time schedule to permit continuous operation of groups of vehicles along the street at a planned speed.
red clearance interval	A clearance interval which may follow the yellow change interval during which both the terminating phase and the next phase display Red signal indications.
red revert	Provision within the controller unit to assure a minimum Red signal indication in a phase following the Yellow Change interval of that phase.
referenced lane	A lane used to define the attributes of another lane.
rest	The interval portion of a phase when present timing requirements have been completed.
right-of-way transfer time	While providing preemption, the maximum amount of time needed for the worst-case condition, prior to display of the clear track green interval. This includes any railroad or traffic signal control equipment time to react to a preemption call, and any traffic signal green, pedestrian walk and clearance, yellow change and red clearance interval for conflicting traffic.
ring	A ring consists of two or more sequentially timed and individually selected conflicting phases so arranged as to occur in an established order.

Term	Definition
Roadside Unit (RSU)	A transportation infrastructure communications device located on the roadside that provides V2X connectivity between OBUs/MUs and other parts of the transportation infrastructure including traffic control devices, traffic management systems, and back-office systems. Note: Devices that are not part of the transportation infrastructure, such as cellular base stations or satellites, are not RSUs. Source: CTI 4001
sample	A collection of data recorded over an identified period of time.
sequence, interval	The order of appearance of signal indications during successive intervals of a cycle.
service request	The information that describes a (signal) priority service to be processed by the ASC. Source: NTCIP 1211 v02
service requestor	A traveler requesting signal service or priority using a connected device. The connected device may be an OBE or a smartphone.
signal control priority strategy	Defines the phases to be serviced, phases to be omitted, and the maximum green times that can be reduced or extended to service a priority request.
Signal Monitoring Unit (SMU)	A subassembly that performs signal monitoring functions within a transportation cabinet. The signal monitoring unit is called a Malfunction Management Unit (MMU) in the NEMA TS 2 Standard and a Cabinet Monitor Unit (CMU) in the ATC Cabinet Standard.
signal plan	A unique set of parameters that define the phase / interval sequence of signal indications and control for one cycle.
signal request	A request for signal service or signal priority via an SAE J2735 Signal Request Message.
single entry	Single entry is a mode of operation (in a multi-ring CU) in which a phase in one ring can be selected and timed alone if there is no demand for service in a nonconflicting phase on the parallel ring(s).
single-ring controller unit	A single-ring CU contains two or more sequentially timed and individually selected conflicting phases so arranged as to occur in an established order.
special function	A control that may activate a device external to the controller unit.
split	The segment of the cycle length allocated to each phase or interval that may occur (expressed in seconds). Note: In an actuated controller unit, split is the time in the cycle allocated to a phase.
standby mode	An operational state called by master or central command which directs the controller unit to select Pattern, Automatic Flash, or Automatic Free based on local Time Base schedule or Interconnect inputs.

Term	Definition
stall condition	An operational state in which the ASC can no longer transmit any data to the management station. Note: The health monitor (watchdog) might or might not work in this situation, but its condition is not able to be transmitted to the management station.
TimeChangeDetail	A data frame that conveys details about the timing of a phase within a movement. The core data concept expressed is the time stamp (time mark) at which the related phase will change to the next state. Source: SAE J2735_202309
Time-based Control (TBC)	A means for the automatic selection of modes of operation of traffic signals in a manner prescribed by a predetermined time schedule.
timing pattern	See "Pattern"
timing plan	The Split times for all segments (Phase/Interval) of the coordination cycle.
track clearing interval	While providing preemption, the time assigned to clear stopped vehicles from the track area on the approach to the signalized highway intersection.
Traffic Signal Controller Broadcast Message (TSCBM)	A message defined in the V2I Hub Interface Control Document containing signal phase and timing (SPaT) information comprised of the SNMP data objects sent by the traffic signal controller to an RSU.
volume	The number of vehicles passing a given point per unit of time.
yellow change interval	The first interval following the green interval in which the signal indication for that phase is yellow.
yield	A command which permits termination of the green interval.
zone	An area in which traffic parameters can be measured and/or traffic data can be generated.

1.5 Abbreviations

The abbreviations (acronyms) used in NTCIP 1202 v04, and not defined in Section 1.4 are defined as follows:

APS	Accessible Pedestrian Signals
CBR	Cars Before Reduction
CMU	Cabinet Monitor Unit
CV	Connected Vehicles
CVRIA	Connected Vehicles Reference Implementation Architecture
DSRC	Dedicated Short Range Communications
ECLA	External Control Local Application
HOV	High Occupancy Vehicle

ITS	Intelligent Transportation Systems
MU	Mobile Unit
OBU	On-Board Unit
PRL	Protocol Requirements List
RSE	Roadside Equipment
RSU	Roadside Unit
RTM	Requirements Traceability Matrix
SIU	Serial Interface Unit
SNMP	Simple Network Management Protocol
SPaT	Signal Phase and Timing (as defined by SAE J2735_202007)
TBR	Time Before Reduction
V2X	Vehicle-To-Everything
VRU	Vulnerable Road User

Section 2 Concept of Operations [Normative]

Section 2 defines the user needs that subsequent sections within NTCIP 1202 v04 address. Accepted system engineering processes detail that requirements should only be developed to fulfill well-defined user needs. The first stage in this process is to identify the ways in which the system is intended to be used. In the case of NTCIP 1202 v04, this entails identifying the various ways in which transportation system managers may use ASC information to fulfill their duties.

This concept of operations provides the reader with:

- a) a detailed description of the scope of NTCIP 1202 v04;
- b) an explanation of how an ASC is expected to fit into the larger context of an ITS network;
- c) a starting point in the agency procurement process; and
- d) an understanding of the perspective of the designers of NTCIP 1202 v04.

Section 2 is intended for all readers of NTCIP 1202 v04, including:

- a) transportation system managers
- b) transportation operations personnel
- c) transportation engineers
- d) system integrators
- e) device manufacturers

For the first three categories of readers, Section 2 is useful to understand how ASC equipment can be used in their system. For this audience, Section 2 serves as the starting point in the procurement process, and enables these readers to become familiar with each feature supported by NTCIP 1202 v04 and determine whether that feature is appropriate for their implementation. If it is, then the procurement specification needs to require support for the feature and all of the mandatory requirements related to that feature.

For the last two categories of readers, Section 2 provides a more thorough understanding as to why the more detailed requirements exist later in NTCIP 1202.

2.1 Tutorial [Informative]

A concept of operations describes a proposed system from the users' perspective. Typically, a concept of operations is used on a project to ensure that system developers understand users' needs. Within the context of NTCIP standards, a concept of operations documents the intent of each feature for which NTCIP 1202 v04 supports a communications interface. It also serves as the starting point for users to select which features may be appropriate for their project.

The concept of operations starts with a discussion of the current situation and issues that have led to the need to deploy systems covered by the scope of NTCIP 1202 v04 and to the development of NTCIP 1202 v04 itself. This discussion is presented in layman's terms such that both the potential users of the system and the system developers can understand and appreciate the situation.

The concept of operations then documents key aspects about the proposed system, including:

- a) **Reference Physical Architecture.** The reference physical architecture defines the overall context of the proposed system and defines which specific interfaces are addressed by NTCIP 1202 v04. The reference physical architecture is supplemented with one or more samples that describe how the reference physical architecture may be realized in an actual deployment.

- b) **Architectural Needs.** The architectural needs section discusses the issues and needs relative to the system architecture that have a direct impact on NTCIP 1202 v04.
- c) **Features.** The features identify and describe the various functions that users may want components of an ASC system to perform. These features are derived from the high-level user needs identified in the problem statement but are refined and organized into a more manageable structure that forms the basis of the traceability tables contained in Section 3 and Annex A.

The architectural needs and features are collectively called user needs. Section 3 uses these user needs in the analysis of the system to define the various functional requirements of an ASC. Each user need shall be traced to one or more functional requirements, and each functional requirement shall be derived from at least one user need. This traceability is shown in the Protocol Requirements List (PRL) as provided in Section 3.3.

While NTCIP 1202 is intended to standardize communications across a wide range of deployments, it is not intended to mandate support for every feature for every deployment. Therefore, the PRL also defines each user need and requirement as mandatory, optional, or conditional. The only items marked mandatory are those that relate to the most basic functionality of the device. To procure a device that meets specific needs, the user first identifies which optional needs are necessary for the specific project.

Each requirement identified is then presented in the Requirements Traceability Matrix (RTM) in Annex A, which defines how the requirement is fulfilled through standardized dialogs and data element definitions provided in Sections 4 and 5.

A conformant device may support other user needs, as long as they are conformant with the requirements of NTCIP 1202 v04 and its normative references (see Section 1.2.1). For example, a device may support data that has not been defined by NTCIP 1202; however, when exchanged via one of the NTCIP 2301 v02 protocols, the data shall be properly registered with a valid OBJECT IDENTIFIER under the Global ISO Naming Tree.

Note: Off-the-shelf interoperability and interchangeability can only be obtained by using well-documented user needs, along with their corresponding requirements and design, that are broadly supported by the industry as a whole. Designing a system that uses environments or features not defined in a standard or not typically deployed in combination with one another inhibits the goals of interoperability and interchangeability, especially if the documentation of these user needs is not available for distribution to system integrators. NTCIP 1202 allows implementations to support additional user needs to support innovation, which is constantly needed within the industry, but users should be aware of the risks involved with using such environments or features.

The concept of operations concludes by describing the degree to which security issues have been addressed by the NTCIP 1202 v04 and by providing a description of how NTCIP 1202 v04 relates to the Architecture Reference for Cooperative and Intelligent Transportation (ARC-IT), formerly known as the U.S. National ITS Architecture.

2.2 Current Situation and Problem Statement [Informative]

Transportation system managers use ASCs to control traffic operations on a roadway. ASCs allow different conflicting movements to travel across a roadway in a safe, orderly manner. In a roadway network, ASCs can be coordinated to improve mobility of certain movements, such as along a major arterial. Implemented correctly, ASCs can reduce:

- a) the number and severity of accidents
- b) delays
- c) stops

- d) fuel consumption
- e) emission of pollutants

There are numerous factors that may affect the operation of an ASC on a roadway. Transportation system managers need to program each ASC to avoid conflicting movements. Conflicting movements are not confined to one specific mode of travel. Travel modes that have movements controllable by an ASC include:

- a) Vehicles
- b) Pedestrians
- c) Bicycles
- d) Special vehicles

Special vehicles are vehicles that have one or more characteristics so that an ASC may treat differently than "ordinary" vehicles. Special vehicles may include emergency vehicles or transit vehicles that request preferential (i.e., priority) treatment, or a high occupancy vehicle (HOV) with its own right-of-way (e.g., an HOV-only lane) through the intersection.

Each travel mode may have its own minimum clearance requirements that are satisfied to provide sufficient time for traffic to traverse the roadway before a conflicting movement is allowed to move.

Transportation system managers can also program an ASC to use inputs from other devices, such as detectors, to measure demand for a specific movement to improve mobility, so that additional time is provided for the movement where the demand exists and less time, if any, is provided for the movement where demand does not exist. An ASC also may be deployed with signal preemption or signal priority capabilities to properly manage movements in special situations. These capabilities, if implemented by the transportation system manager, may allow an emergency vehicle responding to an incident or a railroad at a railroad crossing to preempt the signal and obtain right-of-way. Similarly, signal priority may allow a transit or other fleet vehicle to request preferential treatment through a signalized intersection.

The ASC is also expected to have an important role in the connected vehicle environment. In the United States, the connected vehicle environment has three major goals, to improve safety, mobility and the environment. Many of the key applications being developed in support of these goals near signalized intersections involve the infrastructure providing signal phasing and timing information to "connected" devices, such as connected vehicles and "connected" mobile devices, such as a smartphone.

2.3 Reference Physical Architecture [Informative]

Section 2.3 represents an overview of what a complete ASC system may look like for a transportation agency, and identifies the specific information exchange paths to be addressed by NTCIP 1202 and related standards.

via on-board units (OBUs) or mobile units (MUs) carried by vulnerable road users (VRUs) such as pedestrians, bicyclist, or road workers) using V2X communications.

- e) **Detection Subsystems.** The units that provide inputs for traffic-actuated control, surveillance, or data collection systems. Detection subsystems include a wide variety of devices to detect the presence and other characteristics of travelers within the range of the intersection. In some instances, such detection devices may be connected directly to the CU and collect a variety of data such as volume, occupancy, speed, and headway or used for signal priority or preempt detection.
- f) **External Device.** A physical device (equipment) that may be mounted inside the controller assembly to provide inputs to the CU, to control traffic flow, or use the outputs from the CU for other applications. Examples of external devices include traffic preemptors, signal priority equipment, accessible pedestrian signals, traffic control beacons, the V2X Hub and the MMITSS (Multimodal Intelligent Traffic Signal System) processor.
- g) **Cabinet Subsystems.** The controller assembly that consists of the electrical devices in the cabinet for controlling the operation of a traffic control signal display(s). See Figure 2.

Other components shown in Figure 1 include:

- h) **Connected Vehicle Back Office Systems.** Represent centers that manage and support the connected vehicle environment.
- i) **Other NTCIP Compliant Devices.** Another controller unit that the CU communicates with for coordination of traffic signals. The Other Controller Unit generally controls an adjacent traffic signal.

Note: The deployment of connected vehicle equipment (such as the RSU) is currently very limited, but is expected to be widespread as more V2X equipped vehicles are delivered to the marketplace. Also, Figure 1 is only one possible architecture that might be used for the deployment of the infrastructure for connected vehicles, and other architectures are possible.

2.3.1 ASC Characteristics – Cabinet Specifications

NTCIP 1202 is intended to address the communications interface between any management station and a CU. However, some features defined within NTCIP 1202 apply only to ASCs using a specific transportation cabinet architecture. There are five transportation cabinet architectures that are commonly used in North America.

- a) **Model 332 Cabinet.** A cabinet specification defined in the Caltrans Transportation Electrical Equipment Specification (TEES).
- b) **NEMA TS 1 Cabinet.** A cabinet architecture defined in NEMA TS 1.
- c) **NEMA TS 2 Type 2 Cabinet.** A cabinet architecture defined in NEMA TS 2.
- d) **NEMA TS 2 Type 1 Cabinet.** A cabinet architecture defined in NEMA TS 2.
- e) **ATC Cabinet.** A cabinet architecture defined in ATC 5301. Previously called the ITS Cabinet.

Figure 2 shows a more detailed look at the components that may be inside a cabinet subsystem.

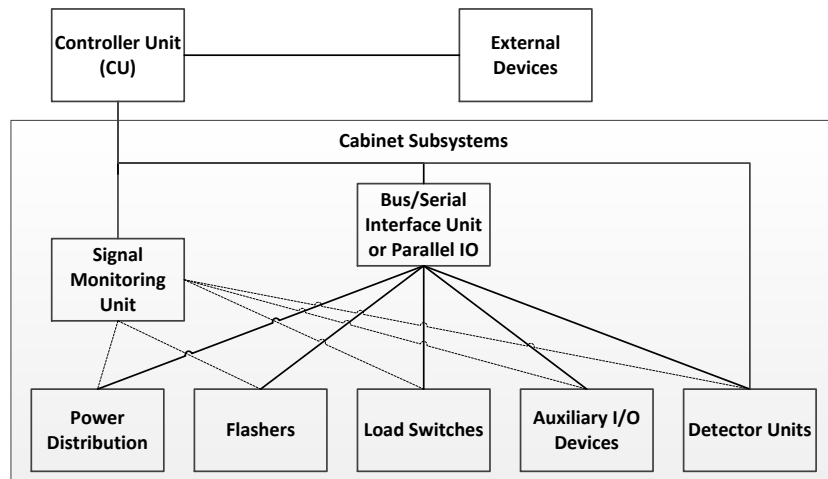

Figure 2 Controller Assembly

Cabinet subsystems include:

- a) **Bus/Serial Interface Unit or Parallel IO.** The communications interface between the CU and the cabinet subsystem. It is called a Bus Interface Unit in the NEMA TS 2 Standard and a Serial Interface Unit (SIU) in the ATC Cabinet Standard. Some systems may use a Parallel Input/Output (IO) for the communications interface. It provides the means by which the CU can control the various cabinet devices, and can monitor inputs to provide analysis and data for use by the traffic management algorithms and the Traffic Management System shown in Figure 1.
- b) **Power Distribution.** Provides protected power distribution to the various components and devices within the cabinet.
- c) **Flashers.** Devices used to open and close signal circuits at a repetitive rate. It is typically used to provide a "fail-safe" flashing operation when the Signal Monitoring Unit determines that there is a failure within the cabinet wiring/devices such as shorted load switches, defective cabinet power supplies, or conflicting signal indications.
- d) **Load Switches.** Devices used to switch power to the signal lamps/indications. This typically includes pedestrian signals, traffic signals, auxiliary signs, and other auxiliary devices.
- e) **Signal Monitoring Unit (SMU).** A subassembly that performs signal monitoring functions within a transportation cabinet. The signal monitoring unit is called a Malfunction Management Unit (MMU) in the NEMA TS 2 Standard and a Cabinet Monitor Unit (CMU) in the ATC Cabinet Standard. When it detects a failure in the operation or a device, it can place the cabinet into the flashing condition using the flashers. It also monitors the power line voltage and places the cabinet into the "fail safe" condition when the operating voltage is below configured minimums and holds the cabinet in the "startup" flashing condition upon power restoration to allow the CU to boot and start normal operation.
- f) **Detector Units.** Devices which support the detection of travelers (e.g., vehicles, pedestrians, bicycles, transit vehicles, emergency vehicles). In some cases, the interface allows the CU to monitor the health and gather additional information from the detection subsystems.

2.3.2 ASC Characteristics – Controller Types

Some features defined within NTCIP 1202 may not be applicable to all ASCs - some features are dependent on whether an ASC is one of the following types of controllers.

- a) **Phase-based controller.** Phase-based signal controllers refer to a device implementing non-conflicting signal indications in response to traffic conditions and the timing constraints

programmed into the device. A phase controls signal indications for one or more non-conflicting traffic movements and may be actuated by those movement's traffic. In a phase-based, fully actuated system, phases without traffic present may be skipped. Green indication durations may vary between pre-set minimum and maximum values, depending on detected traffic and programmed timing information.

- b) **Interval-based controller.** Interval-based signal controllers refers to a device implementing a sequence of defined, discrete steps (i.e., an interval), each driving the signal indications, in a repeating cycle according to the timing constraints programmed into the device. Note that some step sequences may be displayed or skipped in response to traffic conditions.
- c) **Stage-based controller.** Stage-based signal controller refers to a device implementing groups of different sequences of defined, discrete steps (i.e., an interval), each driving the signal indications in a repeated cycle. Groups of intervals may be skipped depending on traffic conditions.

Note: Some controllers can operate either as an interval-based controller or a phase-based controller (but not simultaneously). An agency (procurement) specification may include one or both of these types.

Only phase-based controllers are supported by NTCIP 1202 v04.

2.3.3 ASC Characteristics – Connected Vehicle Interface

NTCIP 1202 v04 also addresses the communications data exchange between an ASC and an RSU. It is through this communications interface with the RSU that an ASC primarily interacts with the connected vehicle environment. Before the ASC - RSU interface can be effectively addressed, an understanding of the functions that need to be performed among an ASC, an RSU, and possibly a third device, called an external device, is helpful.

Some data exchanges defined within NTCIP 1202 v04 for the connected vehicle interface are dependent on the relationship between the ASC, the RSU, and an external device, if one exists between the ASC and RSU. The National ITS Architecture, known as the Architecture Reference for Cooperative and Intelligent Transportation (ARC-IT), implies a logical framework of applications and services that are allocated to the ASC and the RSU. These applications may have needs for information that are provided by the ASC (e.g., information needed to create signal phase and timing (SPaT) messages, status of signal priority requests) or may provide information to the ASC so the ASC may improve safety and mobility at a signalized intersection (e.g., forward a signal priority request, forward location of connected vehicle).

To better understand the connected vehicle environment around the ASC, the functions (and processes) that are needed to be performed have been allocated to one of three logical processes (See Figure 3): the ASC Process, the Connected Vehicle (CV) Application Process, and the RSU process.

NOTE: NTCIP 1202 v03 considered only two logical processes, an ASC Process and a CV Roadside Process.

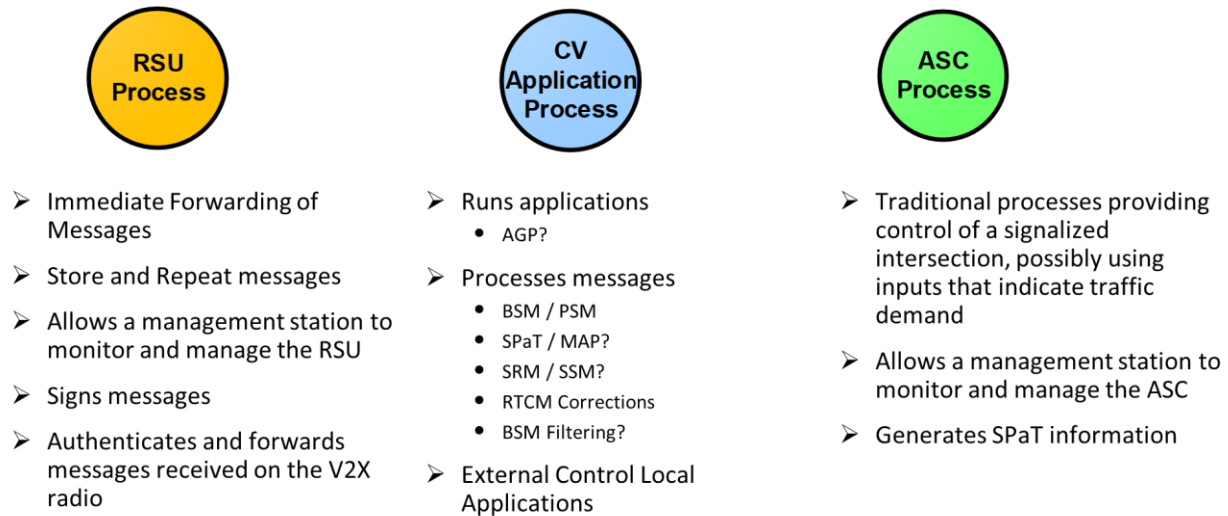

Figure 3 Connected Intersection Logical Processes

The ASC Process consists of the traditional processes providing control of a signalized intersection, possibly using inputs that indicate the traffic demand around the intersection. The source of those inputs may be detection subsystems located within or connected to the same cabinet as the traffic signal controller, or from the CV Application Process. The ASC Process allows a management station, such as a traffic management system, to monitor and manage the traffic signal controller; and generates signal phase and timing information that may be shared with the CV Application Process. These functions are addressed in this standard.

The CV Application Process consists of sub-processes that support the connected vehicle environment. From the context of an ASC, the relevant sub-processes include running intersection CV applications, receives the signal phase and timing information from the ASC Process to generate the SPAT messages to be broadcasted to connected devices, and processing Basic Safety Messages (BSMs) and Personal Safety Messages (PSMs) received from connected devices. A management station (traffic management system) may also configure a CV Application Process to use BSMs and PSMs as inputs to the ASC Process.

The RSU Process consists of sub-processes to manage broadcasting and receiving over-the-air (wireless) messages in a connected vehicle environment. The RSU Process may also perform other functions, such as send and manage security certificates, signing messages that are broadcasted, and authenticate received messages. These functions are addressed in NTCIP 1218, Object Definitions for RoadSide Units.

Figure 4 depicts the interfaces between the different entities and processes that comprise the connected vehicle environment around the ASC. The information exchanges depicted in black, specifically between the RSU Process and the CV Application Process, are expected to be in SAE J2735 format. The information exchanges in orange, specifically between the ASC Process and the CV Application Process and between the ASC Process and the Traffic Management System (management station), are addressed by NTCIP 1202 v04. The information in cyan between the RSU Process and the Traffic Management System (management station) allow a traffic management system to configure the RSU Process and are addressed by NTCIP 1218.

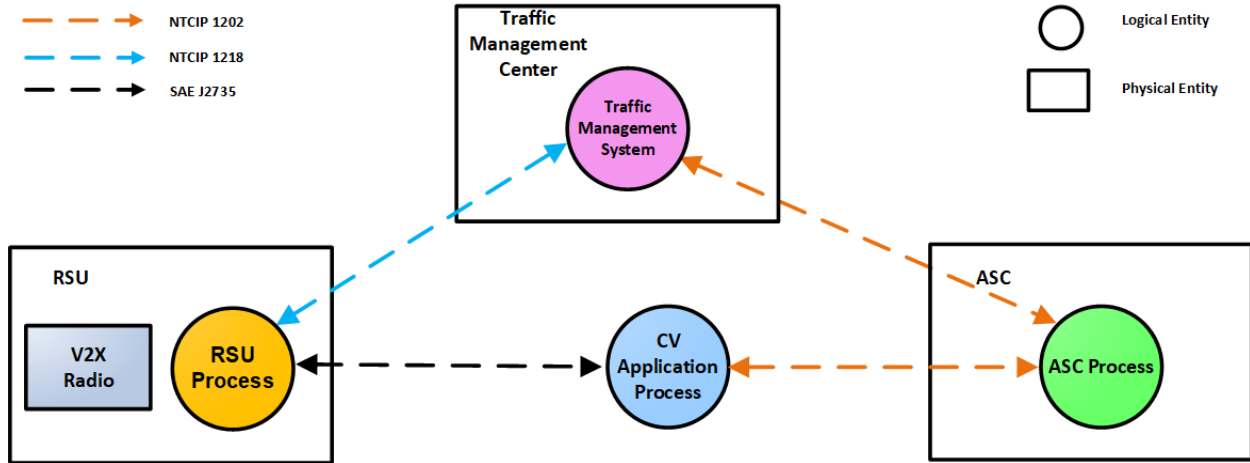

Figure 4 ASC - Connected Vehicle System Context Diagram

From a physical point of view, there are two possible physical architectures that are addressed by NTCIP 1202 v04, defined by where the CV Application Process is physically located, although there may be variations of a physical architecture.

With physical architecture 1, depicted in Figure 5, the CV Application Process is physically located within the ASC, whether it's part of the main ASC application, or a separate application (process) within the ASC. This architecture is applicable when the ASC has sufficient processing power (or a second processor) to generate CV messages, such as SPaT messages, and to process received messages, such as BSMs and PSMs. With this architecture, the ASC receives then processes BSMs and PSMs received by the RSU, which is a field-hardened computing device nearby, or within the same or a separate cabinet as the ASC. The raw BSMs and PSMs received by the ASC are authenticated by the RSU, and possibly filtered by the RSU. Examples of filtered BSMs and PSMs that are forwarded by an RSU include OBUs/MUs at a specific location, vehicle type, and/or direction of travel.

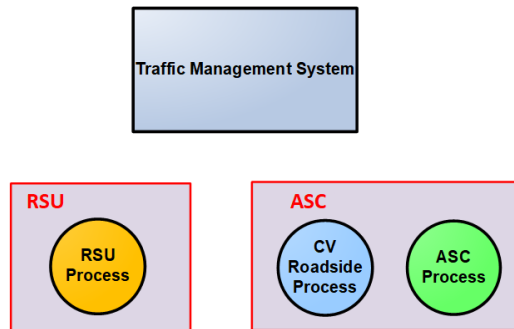

Figure 5 Physical Architecture 1

With physical architecture 1, the UPER-encoded SPaT message is generated by the (physical) ASC and sent to the RSU Process. The ASC also receives the UPER-encoded BSM and PSM messages from the RSU Process.

With physical architecture 2, depicted in Figure 6, the CV Application Process is physically located external to the ASC. The CV Application Process could be physically located (a) in the RSU, (b) an external device, or (c) the functions of the CV Application Process are shared between the RSU and an external device. The external device could be a separate processor in the same cabinet with the ASC. Examples of an external device in this context includes the V2X Hub and the Multi-Modal Intelligent Traffic Signal Systems (MMITSS) processor.

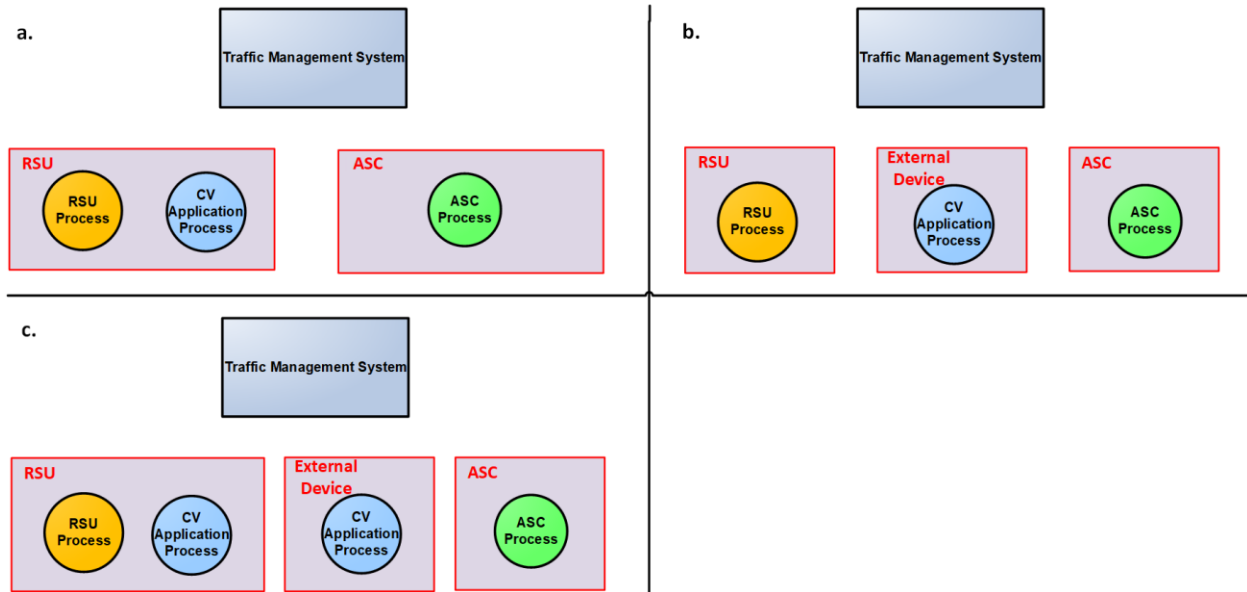

Figure 6 Physical Architecture 2

With physical architecture 2, SPaT information is generated by the (physical) ASC and sent to the CV Application Process, which then generates the SPaT message. The ASC also receives defined information about the location, kinematics, and possibly vehicle types about travelers in the vicinity of the RSU, as processed by the CV Application Process.

2.3.4 ASC Characteristics – Interface with Other Roadside Devices/Processes

NTCIP 1202 v04 also addresses the communications data exchange between an ASC and other roadside devices or processes that may exist within the Reference Physical Architecture (Figure 1) or within the controller assembly (Figure 2). The roadside devices or processes considered by NTCIP 1202 v04 include the logical interface with:

- SMU.** A physical device to monitor the operations and devices in the controller assembly. The SMU is called a Malfunction Management Unit (MMU) in the NEMA TS 2 Standard and a Cabinet Monitor Unit (CMU) in the ATC Cabinet Standard. The SMU may inform the ASC when failures in controller assembly are detected, when the cabinet is in a "fail safe" condition (i.e., flashing), or when operating voltages are below configured minimums.
- External Device.** A physical device, defined above in Section 2.3.
- External Control Local Application (ECLA).** A logical entity that adjusts the signal timing in effect to accommodate different traffic patterns in real-time. An example of an ECLA is a traffic adaptive algorithm application external to the ASC, but asserting a higher-level control over the ASC. The ECLA may also be physically located in an external device or at a traffic management center.

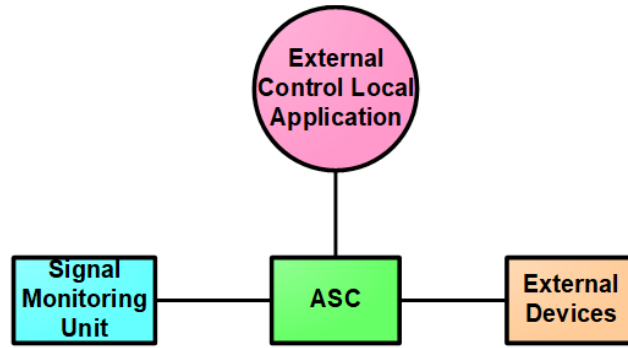

Figure 7 Roadside Process/Devices Interface

2.4 Architectural Needs

NTCIP 1202 v04 addresses the interface between an ASC and one or more management stations (e.g., central computers, laptops, RSUs, peer controller units, etc.). A management station needs to monitor the status of the ASC, manage the database in the ASC, and control the ASC. The management station also needs to retrieve data that has been collected by the ASC. After the management station has retrieved the data of interest, a manager can use the retrieved data to make decisions and initiate other events (such as changes to the ASC timing pattern) to better manage the transportation system.

NTCIP 1202 v04 also addresses the interface between an ASC with other roadside devices and processes, such as the CV Application Process. The CV Application Process needs data from the ASC about current and future signal phasing and timing information, so the CV Application Process can forward this information to connected devices. For the interfaces between an ASC and a roadside device/process, the ASC may act as a management station, and the other device/process acts as an agent/server.

To enable communications between these components, the transportation system manager needs to establish a communication system that links the ASC with a management station. For some systems, the resources required for communications may be minimal and as such the system may be designed for constant polling; other systems may require significant resources for communicating with the ASC and as such the system may be designed to minimize data exchanges. When deploying an ASC, the system designer needs to consider which of the following operational environments need to be supported.

An ASC is expected to operate in the communications environment defined as follows.

2.4.1 Provide Live Data

The typical operational environment allows a management station to monitor and control the ASC by issuing requests (e.g., requests to access information, alter information, or control the device). In this environment, the ASC responds to requests from the management station (e.g., through the provision of live data, success/failure notice of information alteration, or success/failure of the command). This environment may also be used to allow an ASC to monitor another roadside process or device by issuing requests (e.g., request to access information).

2.4.2 Provide Pre-Defined Data Blocks

Some operational environments have limited data capacity due to limitations in the data rates of the media and/or due to multiple entities or devices sharing the same communications channel. In such environments, a transportation manager needs to exchange sets of data together so that data can be transmitted more efficiently over telecommunications networks, thereby conserving the limited data capacity of the channel. This capability reduces the upload and download times of data between a management station and an ASC, or an ASC with another device (e.g., CV Application Process). The

sets of data may be standardized, pre-defined blocks of data or run-time definable sequences addressing functional areas associated with ASCs.

2.4.3 Provide for Log Data Local Storage and Retrieval

In a typical operational environment, the ASC needs to provide logged data to the management station for diagnostic purposes, and for operational environments (e.g., dial-up links) that do not have always-on connections. For example, logged data may include the time when the cabinet door is opened. The event log needs to be cleared either in a last-in last-out basis or by the management station because of limited storage space in the ASC.

2.4.4 Provide for Database Management

Traffic signal controllers are safety critical devices to manage the traffic movements for vehicles, pedestrians, bicycles, transit, and others are intersecting roadways (or railroad crossings). To ensure that the data downloaded from a central system software to an ASC makes logical sense, consistency checks on the downloaded need to be performed by the ASC. The user needs to therefore be able to manage the database by being able to open the database to write data, ensure that the downloaded data was received, command the ASC to perform a verification / consistency check the downloaded data, and to close the database to make the downloaded data available to the operational aspects of the ASC. Additionally, should there be any errors, the user needs to be able to determine the source of the error within the downloaded data.

2.4.5 Condition-based Exception Reporting

In some operational environments, it may be desirable to have the ASC automatically transmit data to the management station when certain conditions occur. Under this scenario, a manager can program the information to be automatically reported to the management station when a specified condition occurs. An example is a manager wants to know when a cabinet door is opened, when the ASC goes to an error flash condition, or when a phase becomes active; these conditions can be programmed to cause the transmission of the alarm objects thus providing the management station with information regarding the change of state at the transportation cabinet.

2.5 Features

Section 2.5 identifies and describes the various features that may be offered by the ASC. It is divided into the following:

- a) Manage the ASC Configuration
- b) Manage Signal Operations
- c) Manage Detectors
- d) Manage Connected Vehicles Interface
- e) Backwards Compatibility Features

2.5.1 Manage the ASC Configuration

This section identifies and describes the various features related to managing the configuration of the ASC. It consists of the following features:

- a) Retrieve Device Identity
- b) Manage Communications
- c) Monitor Cabinet Environment
- d) Monitor Power
- e) Retrieve Operational Performance Data
- f) Manage Auxiliary External Inputs/Outputs
- g) Manage Database

- h) Manage Peer-to-Peer with Other Devices
- i) Manage Signal Monitoring Unit Information
- j) Manage Interface with External Detectors
- k) Manage ASC Clock
- l) Manage External Local Control Application

2.5.1.1 Manage Device Identity

A manager needs to manage basic information about the ASC. This information consists of its location (latitude and longitude), and the make, model, and version of the device components. The device components can be a hardware, software, or firmware component, and could be a physical or logical entity in nature. This feature allows a manager to verify the identity of the ASC in the field and what software or firmware version is installed. This feature also allows a manager to retrieve a unique identifier of the device as provided by the device manufacturer.

2.5.1.2 Manage Communications

A manager needs to manage each communications port in the ASC. This feature consists of enabling or disabling the communications ports, and configuring or retrieving the port address (e.g., IP address). This feature allows a manager to disable an unused communications port for security purposes or to reconfigure the ASC for a new communications media.

2.5.1.3 Manage Cabinet Environment

A manager needs to monitor the transportation cabinet operating environment. This feature allows a manager to monitor for unsafe operating environments for the ASC so proper precautions can be taken. Unsafe operating environment consists of an open transportation cabinet door, high cabinet temperatures, or an indication that the cabinet fan has turned on.

2.5.1.4 Monitor Power

A manager needs to monitor the power for the ASC. This feature allows a manager to determine whether the power sources for the transportation cabinet are suspect and need maintenance or whether the intersection is operating on an alternate power source. For example, some ASCs use AC power for its battery.

2.5.1.5 Retrieve Operational Performance Data

A manager needs to retrieve operational data from the ASC for the analysis of the signal timing efficacy. The operational data consists of frequent snapshots of signal operations data and detector data and allows a manager to view the temporal relationship between signal indications and traveler arrivals.

An example of this operational data is the Indiana Traffic Signal Hi Resolution Data Logger Enumerations. This feature provides a manager with the information to evaluate the performance of signal operations, such as the quality of progression of traffic along arterials, or measuring the amount of unused green time during a cycle. A manager may wish to monitor the operational data or store the operational data in a log for retrieval at a later time.

2.5.1.6 Manage Auxiliary External Inputs/Outputs

A manager needs to monitor and control auxiliary external devices (i.e., non-signal control) through the ASC. This feature allows a manager to activate auxiliary external devices or functions that may be tied to other transportation operational needs. For example, the ASC may be co-located with a trail-blazing sign utilized for special events and not associated with traffic signal operations.

2.5.1.7 Manage Database

A manager needs to manage the configuration and version of the database in the ASC. This feature allows a manager to determine if the ASC has the correct and expected version of the database.

2.5.1.8 Manage Peer-to-Peer with Other Devices

A manager needs to configure the ASC to retrieve and transmit data to another NTCIP-compliant device based on an event or events. This feature allows a manager to use events at an ASC as an input to another NTCIP-compliant device. The data is intended for informational purposes only and are not intended to be commands to control another NTCIP-compliant device.

For example, an ASC may detect a light rail at the intersection and then transmit that information to the downstream ASC as an advanced light rail call.

2.5.1.9 Manage Signal Monitoring Unit Information

A manager needs to configure an ASC to be aware of potential malfunctions or errors detected by the SMU. An ASC may be receiving information from the SMU, which is monitoring transportation cabinet operations and conditions. This feature allows a manager to be informed about the traffic signal operations to schedule preventative maintenance or dispatch maintenance crews.

2.5.1.10 Manage Interface with External Detectors

A manager needs to configure an ASC to receive and use detector data for traffic signal operations. This feature allows a manager to configure the source and type of detector data received, so the ASC may use this detector data for actuated operations or a traffic adaptive algorithm. The detector data provides details about traveler demand around the traffic signal so the controller can efficiently manage traffic signal operations. External detector data may include queue length information on an approach, turning movement volumes, or travel time for a specific movement through an intersection.

2.5.1.11 Manage ASC Clock

A manager needs to configure the ASC clock to determine the accurate time so the ASC can coordinate traffic operations on a roadway with other signalized intersections, and provide accurate information on signal operations to travelers. This feature allows a manager to configure the time source(s), the clock status, and configure what time zone the ASC is located in.

2.5.1.12 Manage External Control Local Application State

A manager needs to configure the ASC to exchange information with an External Control Local Application (ECLA) that is asserting a higher-level control over the ASC. This feature allows a manager to enable the ASC to exchange information with an ECLA so the ASC can generate accurate SPaT data to a CV Application Process. This data includes signal timing durations that are selected by the ECLA.

2.5.2 Manage Signal Operations

This section identifies and describes the various features for an ASC to monitor and control traffic signal operations. It consists of the following features:

- a) Manage Signal Configuration
- b) Monitor Signal Operations Status
- c) Control Signal Operations

2.5.2.1 Manage Signal Configuration

This feature allows a manager to retrieve and configure the traffic signal operations of an ASC. It consists of the following sub-features.

- a) Manage Controller Startup Functions
- b) Manage Phase Configurations
- c) Manage Coordination Configurations
- d) Manage Timing Patterns
- e) Manage Splits Configurations
- f) Manage Ring Configurations
- g) Manage Channel Configurations
- h) Manage Overlap Configurations
- i) Manage Preempt Configurations
- j) Manage Timing Pattern Scheduler
- k) Manage Action Scheduler
- l) Manage I/O Mapping
- m) Manage Intra-Cabinet Communications Configuration
- n) Manage Pedestrian Support

2.5.2.1.1 Manage Controller Startup Functions

A manager needs to retrieve and configure the startup capabilities and functions of the ASC. This feature allows a manager to define the Start-Up times upon powerup, set the backup time, and set the minimum clearance times for the ASC.

2.5.2.1.2 Manage Phase Configurations

For a phase-based controller, a manager needs to retrieve and configure the phases for the ASC. This feature allows a manager to set the minimum durations, maximum durations, clearance times, allowable concurrent phases, and other phase-related features and options for all travel modes (vehicles, pedestrians, bicycles, special vehicles).

2.5.2.1.3 Manage Coordination Configurations

A manager needs to retrieve and configure the coordination modes for the ASC. This feature allows a manager to configure the allowable operational, correction and force modes, and coordination point within a phase to be used for signal coordination.

2.5.2.1.4 Manage Timing Patterns

A manager needs to retrieve and configure the timing patterns stored in the ASC. This feature allows a manager to configure each timing pattern, which consists of a cycle length, splits, offsets and the phase sequences. A manager may also specify a [default timing pattern](#).

2.5.2.1.5 Manage Splits Configurations

A manager needs to retrieve and configure the splits stored in the ASC. This feature allows a manager to configure a split, which consists of the phase assignment, the coordinated phase, the split time, and the split mode.

2.5.2.1.6 Manage Ring Configurations

A manager needs to retrieve and configure the rings in the ASC. This feature allows a manager to configure each ring, which defines the sequence of phases for that ring.

2.5.2.1.7 Manage Channel Configurations

A manager needs to retrieve and configure the channel parameters in the ASC. This feature allows a manager to configure the control source, the type of phase the channel is controlling (e.g., vehicle phase, pedestrian phase, bicycle phase, overlap), and the flash and dimming characteristics for each channel.

2.5.2.1.8 Manage Overlap Configurations

A manager needs to retrieve and configure the overlap functions in the ASC. This feature allows a manager to configure the type of overlap operation, the included phases, the modifier phases, any overlap extensions and clearance times for each overlap.

2.5.2.1.9 Manage Preempt Configurations

A manager needs to retrieve and configure the preempts in the ASC. Preempts are used to service special needs at an intersection, such as for a railroad crossing or emergency vehicles responding to an incident. This feature allows a manager to retrieve and configure the minimum durations, phase settings, outputs and clearance times whenever a preempt signal is detected, how the controller enters into and exits out of preemption and to define the priority of different preempt inputs into the ASC. This feature also allows a manager to configure the ASC to enable or disable the preempt under certain conditions, such as time-of-day, or to configure the ASC to select alternate exit strategies based on input conditions.

2.5.2.1.10 Manage Timing Pattern Scheduler

A manager needs to retrieve and configure the scheduler in the ASC to implement a timing pattern based on time. This feature allows a manager to configure the ASC to implement timing patterns based on calendar days, days of the week and/or times of day.

2.5.2.1.11 Manage Action Scheduler

A manager needs to retrieve and configure the scheduler in the ASC to perform a function or a group of functions. The action scheduler allows a manager to activate an output, enable a parameter (e.g., max2), configure the ASC log, or program the condition-based exception reporting based on calendar days, days of the week and/or times of day.

For example, a manager may program the action scheduler to activate the special function output every weekday when a nearby school is in session and configure the ASC to operate in nonactuated mode during the same period of time. A manager may also configure the log not to record actuations, and to program the condition-based exception reporting not to report actuations during that same period of time.

2.5.2.1.12 Manage I/O Mapping

A manager needs to retrieve and configure the input/output mapping in the ASC. This feature allows a manager to change the input and outputs for an ASC so unused inputs or outputs, as defined by a standard specification, can be used and configured as needed. This feature also allows a manager to reset the input/output mapping to a default configuration, and configure the conditions when changes to input/output mapping can be accepted by the ASC.

2.5.2.1.13 Manage Intra-Cabinet Communications Configuration

A manager needs to retrieve and configure the ASC's intra-cabinet communications port. For NEMA TS 2 type controllers, this is the NEMA TS 2 Port 1 in the ASC and allows a manager to indicate if a device is present on Port 1. For controllers in an ATC Cabinet, this is Serial Bus 1 (siuport1).

2.5.2.1.14 Manage Pedestrian Support

A manager needs to retrieve and configure the ASC to support Accessible Pedestrian Signals (APS). This feature enables an ASC to provide information about pedestrian signal timing to pedestrians via non-visual formats such as audible tones, verbal messages, and/or vibrating surfaces. This may include mobility impaired pedestrians. This feature also allows the ASC to exchange information with pedestrian countdown timers.

2.5.2.2 Monitor Signal Operations Status

This feature allows a manager to monitor the traffic signal operations and status of an ASC. It consists of the following sub-features.

- a) Determine Controller Health
- b) Determine Mode of Operation
- c) Monitor Signal Indication
- d) Monitor Phase Status
- e) Monitor Ring Status
- f) Monitor Channel Status
- g) Monitor Overlap Status
- h) Monitor Preempt Status
- i) Monitor Special Function Outputs
- j) Monitor Timebase Action Status
- k) Monitor Intra-Cabinet Communications Configuration
- l) Monitor Peer-to-Peer State
- m) Monitor Signal Monitoring Unit

2.5.2.2.1 Determine Controller Health

A manager needs to monitor the health of the ASC. This feature allows a manager to determine if the essential functions and elements of the ASC are operating properly. ASC system error conditions and faults to be monitored are processor stall conditions (timeouts), memory faults, task (i.e., process) failures, communication timeouts or errors from a management station, and suspect power problems. ASC operational error conditions and faults to be monitored are conflicts, cycle failures, and coordination failures.

2.5.2.2.2 Determine Mode of Operation

A manager needs to determine the current mode of operation in the ASC. It consists of the following sub-features.

2.5.2.2.2.1 Monitor Unit-wide General Operations

A manager needs to determine if the ASC as a unit is operational, provides unit-wide control status information, and monitors other unit-wide parameters such as **automatic detector calls**, dimming, and interconnect status.

2.5.2.2.2.2 Monitor Flashing

A manager needs to determine if the ASC is in a flashing condition and the reason for the flashing condition. If a condition is detected in the controller assembly that may comprise public safety, the ASC generally reverts to a flash condition. This feature allows a manager to determine if the cause of a flash condition is normal (e.g., the ASC was commanded to flash) or if a safety critical condition was detected.

2.5.2.2.2.3 Monitor Current Timing Pattern

A manager needs to retrieve information about the timing pattern, mode of operation and its source (e.g., program entry, time base control, system interface, etc...) running in the ASC. This feature allows a manager to determine the current timing pattern and mode of operation in effect, and the programmed timing pattern and mode of operation (what should be in effect).

2.5.2.2.2.4 Monitor Current Cycle

A manager needs to retrieve information about the current timing pattern cycle in the ASC. This consists of the current split, its coordination state, the duration of time since the current cycle started, and the duration of time before the current phase ends.

2.5.2.2.3 Monitor Signal Indication

A manager needs to retrieve the status of each signal indication configured in the ASC. This feature indicates if each signal indication is on, off, flashing or dimmed. This feature allows a manager to view the signal indications on a map.

2.5.2.2.4 Monitor Phase Status

For a phase-based controller, a manager needs to retrieve the status of each phase configured in the ASC. This feature indicates if each phase is active or not (including clearance intervals) and if there is an active vehicle or pedestrian call. This feature also indicates which phases are expected to be active after the termination of an active phase. This feature allows a manager to observe and review signal operations.

2.5.2.2.5 Monitor Ring Status

For a phased-based controller, a manager needs to retrieve the status of each ring output configured in the ASC. This feature allows a manager to determine what state (minimum green, extension, yellow change, red clearance, red rest, etc...) and interval the ring is currently in.

2.5.2.2.6 Monitor Channel Status

A manager needs to retrieve the status of each channel output configured in the ASC. This feature allows a manager to determine if each channel output is red, yellow or green, and the current measured voltages and electrical current.

2.5.2.2.7 Monitor Overlap Status

A manager needs to retrieve the status of each overlap configured in the ASC. This feature allows a manager to determine if each overlap is red, yellow or green.

2.5.2.2.8 Monitor Preempt Status

A manager needs to retrieve the status of the preempt state for each preempt input configured in the ASC. For each preempt input, this feature indicates whether an input signal is active, and if the preempt service has started, if the preempt is being delayed, is linked to another preempt sequence, is overriding another preempt sequence, is being overridden by another preempt sequence, the preempt interval (e.g., in dwell) or if the preempt is exiting out of preempt service.

2.5.2.2.9 Monitor Special Function Outputs

A manager needs to retrieve if each special function output configured in the ASC is active. For example, an ASC near a school may use its special function outputs to turn on a flashing beacon to indicate a lower speed limit when a timing pattern associated with traffic arriving and leaving the school are in effect.

2.5.2.2.10 Monitor Timebase Action Status

A manager needs to retrieve which timebase action entry is currently in effect in the ASC.

2.5.2.2.11 Monitor Intra-Cabinet Communications Configuration

A manager needs to retrieve if the ASC's intra-cabinet communications port is online. For NEMA TS 2 type controllers, this is the NEMA TS 2 Port 1 in the ASC. For traffic signal controllers in an ATC Cabinet, this is Serial Bus 1.

2.5.2.2.12 Monitor Peer-to-Peer State

A manager needs to retrieve and view the data that an ASC receives or sends to other NTCIP-compliant devices. This feature allows a manager to determine the data being exchanged and the event that resulted in the communication.

2.5.2.2.13 Monitor Signal Monitoring Unit

A manager needs to retrieve the data that an ASC has received from the Signal Monitoring Unit (SMU) in the cabinet. This feature allows a manager to be aware of potential malfunctions or errors detected by the SMU so a manager may dispatch personnel to remedy the situation or perform preventative maintenance. This feature also allows the ASC to be aware that the transportation cabinet is in cabinet flash, and to confirm the outputs between what the ASC commanded and actual field conditions, depending on the SMU type.

For example, the SMU may detect a loss of current on a signal circuit. The ASC may be configured to record the information to provide to a manager when it detects a configured loss of current on any signal circuit. A loss of current may be indicative of a potential issue that may require preventative maintenance. The SMU also may drive the cabinet to fail-flash (cabinet flash) when it detects a configured loss of current on any signal circuit.

2.5.2.3 Control Signal Operations

This feature allows a manager to control the signal operation of an ASC. It consists of the following sub-features:

- a) Control ASC-wide General Operations
- b) Command Timing Pattern
- c) Phase Requests
- d) Activate Preempt
- e) Control Ring Operations
- f) Activate Special Function Output
- g) Control Frame 40
- h) Activate Action Plan
- i) Remote Manual Control

2.5.2.3.1 Control ASC-wide General Operations

A manager needs to control ASC-wide operational features within the ASC such as external minimum recalls, automatic detector calls, dimming, interconnect, and enabling/disabling remote commands to the ASC.

2.5.2.3.2 Command Timing Pattern

A manager needs to command the ASC to a mode of operation, activate a timing pattern or activate a signal plan. This feature allows a manager to command the ASC to a standby mode, to free mode, or to flash, and to establish the system reference point. A manager may do this in the event of inclement weather or special events.

2.5.2.3.3 Phase Requests

A manager needs to control the duration and inclusion of phases for the current (signal) cycle of an ASC. This feature consists of the capability to omit phases, hold phases, force phases off, and to place calls.

2.5.2.3.4 Activate Preempt

A manager needs to activate a preempt input configured in the ASC. This feature allows a manager to force the ASC to request a preempt sequence state for diagnostic purposes or during special events.

2.5.2.3.5 Control Ring Operations

A manager needs to control ring operations of an ASC. This feature allows a manager to stop the ring timing, to activate a force off, or force the ring to rest in red.

2.5.2.3.6 Activate Special Function Output

A manager needs to activate a special function output configured in an ASC. This special function output may be used to activate other devices, such as flashing beacon or a blank out sign associated with a timing pattern.

2.5.2.3.7 Control Frame 40

For NEMA TS 2 type controllers, a manager needs to enable or disable Frame 40 messages from the ASC to a device at the Port 1 address. Frame 40 is used to poll the secondary stations for a secondary-to-secondary message exchange.

2.5.2.3.8 Activate Action Plan

A manager needs to activate a pre-defined group of functions configured in an ASC. This feature allows a manager to command the ASC to perform a group of functions. The functions consist of allowing a manager to activate an output, configure the ASC (e.g., maximum2), configure the ASC log, or program the condition-based exception reporting.

2.5.2.3.9 Remote Manual Control

A manager needs to command the ASC to remotely advance the signal controller through the phases or intervals. This feature allows a manager to remotely and manually control a signal controller. Examples of when a manager may wish to manually control an intersection would be for special events, such as sporting events, parades and large concerts, where traffic congestion is far in excess of normal volumes.

2.5.3 Manage Detectors

This section identifies and describes the various features to monitor and control the detector inputs to the ASC. A detector may be used to identify demand for signal service. The user needs to monitor and control detector inputs consist of the following features:

- a) Manage Detector Configuration
- b) Monitor Detector Status
- c) Monitor Detector Health
- d) Control Detectors
- e) Manage Detector Data
- f) Monitor Detector Data from External Devices

2.5.3.1 Manage Detector Configuration

A manager needs to retrieve and configure the detectors connected to the ASC. This feature allows a manager to define the travel mode being detected (vehicle, pedestrian, transit, and bicycle), select phase assignments, define capabilities, and define the criteria for detector faults. The criteria for a detector fault consist of the amount of time between detector actuations, amount of time with continuous actuations, and excessive actuations over a period of time.

2.5.3.2 Monitor Detector Status

A manager needs to monitor activations for detectors configured in the ASC. This feature allows a manager to determine the presence of vehicles, pedestrians or other travelers on the roadway.

2.5.3.3 Monitor Detector Health

A manager needs to monitor the health of the detectors configured in the ASC. This feature allows a manager to determine if the detectors are operating correctly or if a fault has been detected so maintenance personnel can be dispatched to repair the detectors if necessary.

2.5.3.4 Control Detectors

A manager needs to control a detector configured in the ASC. This feature allows a manager to clear a detector fault and place the detector back in service, and to activate a call on a detector.

2.5.3.5 Manage Detector Data

A manager needs to set up the ASC to collect data from detectors configured in the ASC. This feature allows a manager to retrieve reports from the ASC on the data measured by the detectors over a user-defined period. This data consists of volumes, occupancies, and speeds as appropriate.

2.5.3.6 Monitor Detector Data from External Detectors

A manager needs to monitor the detector data received from external detectors. This feature allows a manager to retrieve reports from the ASC on the data received from external detectors.

2.5.4 Manage Connected Vehicles Interface

This section identifies and describes the various features that support the interface between an ASC and a CV Application Process in a connected vehicle environment. The connected vehicle environment is expected to use the SAE J2735 – V2X Communications Message Set Dictionary as the information standard. Several messages in SAE J2735 are pertinent to ASCs and are addressed within NTCIP 1202 v04. These messages are:

- a) **Signal Phase and Timing (SPaT) Message.** A broadcasted message providing signal phase and timing information for one or more ASC indicating the state of each permitted intersection maneuver and when an active maneuver terminates. The current signal status is also sent. This message is intended for connected devices in the broadcast vicinity of an ASC.
- b) **Basic Safety Message.** A broadcasted message providing "basic" information about the location and movements of a "connected" vehicle, including its current location, speed, acceleration, and direction of travel.
- c) **Personal Safety Message.** A broadcasted message providing "basic" information about the location and movements of a "connected" mobile device carried by a Vulnerable Road User (VRU), such as a pedestrian, bicyclist or road worker, or integrated in a device used by the VRU, such as a bicycle or wheelchair.

The features offered by an ASC to support the connected vehicle environment are organized by interface:

- a) the interface between a management station and the ASC; and
- b) the interface between the ASC and the CV Application Process.

2.5.4.1 Connected Vehicle Interface: Management Station – ASC Interface

The following subsections identify and describe the various features that may be offered between a management station and an ASC. These features are:

- a) Manage CV Application Process Interface
- b) Manage CV Application Process Interface Watchdog
- c) Manage Signal Phase and Timing Data
- d) Manage Assured Green Period

2.5.4.1.1 Manage CV Application Process Interface

A manager needs to retrieve and configure the interface between the ASC and a CV Application Process. This feature allows a manager to configure operational control information of how often information is exchanged between the ASC and an CV Application Process.

2.5.4.1.2 Manage CV Application Process Interface Watchdog

A manager needs to retrieve and configure an CV Application Process watchdog within the ASC. This feature allows the ASC to monitor the period of time elapsed between data exchanges across an ASC and CV Application Process interface. If the time elapsed exceeds a configured threshold, the ASC hardware is reset to clear the potential stall condition.

2.5.4.1.3 Manage Signal Phase and Timing Data

Some of the key applications that have been developed within the connected vehicle environment are related to intersection safety. For signalized intersections, this involves an RSU broadcasting SPaT messages, as defined by SAE J2735, to connected vehicles in the vicinity. Nearly all the data in the SPaT message originates from the ASC, so the ASC needs to exchange this data with the CV Application Process. However, a manager in a traffic management center needs to monitor what data is being provided to the CV Application Process to broadcast to connected devices. This feature allows a manager to manage and view the contents of the signal phase and timing data that the ASC is exchanging with the CV Application Process.

2.5.4.1.4 Manage Assured Green Period

A manager needs to configure the ASC to provide an Assured Green Period (AGP) at connected intersections. This feature allows a manager to define the parameters to calculate the AGP, establish a

Red Light Violation Warning (RLVW) detection zone (RDZ), and the ability to provide an assured green end time (AGET) when the intersection is under actuated signal control.

The RLVW application decreases the likelihood that the vehicle will be in the intersection during a red signal indication. When a vehicle is approaching an intersection during a green interval, the RLVW application may provide advisories, warnings, or alerts to the driver that they may not clear the intersection before the signal turns red.

2.5.4.2 Connected Vehicle Interface: ASC – CV Application Process Interface

The following subsections identify and describe the various features that may be offered between an ASC and a CV Application Process. These features are:

- a) Exchange Current and Next Movement Information
- b) Exchange Next Occurrence of a Movement
- c) Exchange Presence of Connected Devices
- d) Exchange Roadway Geometrics Information

2.5.4.2.1 Exchange Current and Next Movement Information

An ASC needs to exchange with a CV Application Process what the current and future states of each movement is and when that state will change. This feature allows the ASC to exchange information about when each state of each movement starts and ends. The CV Application Process uses this information for its safety, mobility and environmental applications and to broadcast SPaT messages to connected vehicles and mobile devices. An ASC operating in actuated mode might only be able to provide a time period when an active movement is to terminate. An ASC also may not be able to provide about the next active movement until the end of a current active movement.

2.5.4.2.2 Exchange Next Occurrence of a Movement

An ASC needs to exchange with a CV Application Process the time when each movement will be next permitted (when it is permitted to move again). One of the applications envisioned for the connected vehicle environment is Connected Eco-Driving. This application provides customized real-time driving advice to drivers so that they can adjust their driving behavior to save fuel and reduce emissions. This may include a CV application in the CV Application Process providing recommendations for an optimal speed to equipped vehicles so vehicles arrive at the intersection when the signal indication for their desired movement is green, reducing fuel consumption and emissions created when a vehicle unnecessarily brakes and accelerates.

2.5.4.2.3 Exchange Presence of Connected Devices

An ASC needs to exchange with a CV Application Process the presence of connected devices on the roadway around the ASC in support of the Assured Green Period. This feature allows the ASC to exchange with the CV Application Process information that can be used as a call for actuated movements or to determine the demand for specific movements. The Basic Safety Message and the Personal Safety Message are the primary sources of presence information that are received by a CV Application Process located near the ASC and then exchanged with the ASC.

2.5.4.2.4 Exchange Roadway Geometrics Information

An ASC needs to exchange with a CV Application Process what roadway geometry plan that is currently in effect at the intersection. Each roadway geometry plan may define the pathways where movements are permitted at the intersection when that roadway geometry plan is in effect. A pathway may be a vehicle lane, a pedestrian crossing, a bicycle lane, or a transit right of way. This feature allows the ASC to exchange with the CV Application Process when the roadway geometry plan in effect in the ASC has

changed. The ASC uses this information to confirm that the roadway geometry plan is compatible with the signal operations timing plan in effect.

For example, an ASC may be programmed to use signal timing plans with an intersection roadway geometry with one-way approaches into the intersection. However, if the intersection roadway has been changed to two-way traffic, the ASC needs to confirm that the signal timing plan in effect is still compatible with the new roadway geometry plan that the CV Application Process is broadcasting to travelers.

2.5.4.3 ASC – ECLA Interface

An ASC needs to exchange with an ECLA on what the current and future states of each movement is and when that state will change. This feature allows the ASC to receive information from the ECLA on when each state of each movement starts and ends, when the ECLA is asserting a higher-level control over the ASC. The ASC uses this information to broadcast SPaT messages to connected vehicles and mobile devices.

2.5.5 Backward Compatibility Features

Prior versions of NTCIP 1202 use SNMPv1 as its application layer protocol, while NTCIP 1202 v04 uses SNMPv3 as its application layer protocol. A shortcoming of SNMPv1 is its lack of security – thus *NTCIP 9014, Infrastructure Standards Security Assessment (ISSA)*, published in 2021, recommended migrating the NTCIP center-to-field standards from SNMPv1 to SNMPv3. However, an authentication feature in SNMPv3 breaks backward compatibility for every SNMPv1 message exchanged, thus NTCIP 1202 v04 is not backward compatible with previous versions of NTCIP 1202, so this section is not applicable.

2.6 Security

Section 2.6 identifies and describes the various security features that may be offered by the ASC. It consists of the following sub-features:

- a) Manage Authentication
- b) Manage Accessibility
- c) Manage Users
- d) Log User Access
- e) Manage ASC Interface Security

2.6.1 Manage Authentication

A manager needs to retrieve and configure the ASC to authenticate requests from a manager. This feature allows a manager to authenticate users and passwords in the ASC.

2.6.2 Manage Accessibility

A manager needs to retrieve and configure the ASC to limit access to specific information in the ASC based on the permissions assigned by a manager.

2.6.3 Manage Users

A manager needs to retrieve and configure a user's profile in the ASC. Each user profile consists of a user, its password and its access rights.

2.6.4 Log User Access

A manager needs to retrieve and configure the ASC to log when and what requests were made by a manager. This feature allows a manager to track who made what changes to the ASC security

configuration, or commanded the ASC to perform a security-related function. This feature is only accessible by a system administrator.

2.6.5 Manage ASC Interface Security

The following subsections identify and describe the various security features for the interfaces between the ASC and other devices and processes. These features are:

2.6.5.1 Manage Security for the ASC to RSU Interface

A manager needs to manage the security features for the ASC to the RSU communications interface as defined by other ITS standards. Other ITS standards may impose additional needs on this communications interface.

2.6.5.2 Manage Security for Other ASC Interfaces

A manager needs to manage the security features for the communications interface between the ASC and other devices or processes. These security features may be defined by other ITS standards.

2.7 Operational Policies and Constraints

The ASC WG recognize that the following constraints may apply.

- Public agencies may implement operational policies, rules, or regulations that takes precedence over the use of this standard. No governmental operational policies, rules or regulation shall be violated when applying NTCIP 1202.
- It is the operational policy of some agencies that authorized personnel is/are present at the physical location of the ASC, before an ASC accepts a change to the configuration of the ASC. This operational policy is usually enforced by requiring that the door of the transportation cabinet containing the ASC is open.
- The operation and maintenance of the connected signalized intersection uses the traffic signal timing principles and practices that have guided signal timing operations for many decades. Many of these principles and practices have been studied, researched, and time tested. Significant changes to these principles and practices may require additional studies and research before they can be adopted and deployed.

2.8 Relationship to the ITS National Architecture [Informative]

Architecture Reference for Cooperative and Intelligent Transportation, known as ARC-IT, combines the National ITS Architecture and the Connected Vehicle Reference Implementation Architecture (CVRIA). NTCIP 1202 v04 addresses many ARC-IT flows associated with the operation of an ASC.

NTCIP 1202 v04 addresses fourteen (14) ARC-IT flows between a Traffic Management Center (TMC) and a Traffic Signal Controller (ITS Roadway Equipment (IRE)) that are associated with the operation of an ASC. These flows are:

- a) **Rail Crossing Control Data:** Data required for Highway-Rail Intersection (HRI) information transmitted at railroad grade crossings and within railroad operations.
- b) **Rail Crossing Request:** A request for highway-rail intersection status or a specific control request intended to modify HRI operation.
- c) **Rail Crossing Status:** Status of the highway-rail intersection equipment including both the current state or mode of operation and the current equipment condition.
- d) **Right-of-Way Request Notification:** Notice that a request has occurred for signal prioritization, signal preemption, pedestrian call, multi-modal crossing activation, or other sources for right-of-way requests.

- e) **Signal Control Commands:** Control of traffic signal controllers or field masters including clock synchronization.
- f) **Signal Control Coordination:** The direct flow of information between field equipment. This includes configuration and control of traffic signal controllers and field masters. Configuration data and operational status of traffic signal control equipment including operating condition and current indications are returned.
- g) **Signal Control Device Configuration:** Data used to configure traffic signal control equipment including local controllers and system masters.
- h) **Signal Control Plans:** Traffic signal timing parameters including minimum green time and interval durations for basic operation and cycle length, splits, offset, phase sequence, etc. for coordinated systems.
- i) **Signal Control Status:** Operational and status data of traffic signal control equipment including operating conditions and current indications.
- j) **Signal Fault Data:** Faults from traffic signal control equipment.
- k) **Signal System Configuration:** Data used to configure traffic signal systems including configuring control sections and mode of operation (time-based or traffic responsive).
- l) **Traffic Detector Data:** Raw and/or processed traffic detector data which allows derivation of traffic flow variables (e.g., speed, volume, and density measures) and associated information (e.g., congestion, potential incidents). This flow includes the traffic data and the operational status of the traffic detectors.
- m) **Traffic Detector Control:** Information used to configure and control traffic detector systems such as inductive loop detectors and machine vision sensors.

NTCIP 1202 v04 also addresses fifteen (15) ARC-IT flows between a Traffic Signal Controller, represented as an ITS Roadway Equipment (IRE), and an RSU, represented as a Connected Vehicle Roadside Equipment (CVRE). These flows are:

- a) **Arriving Train Information:** Information for a train approaching a highway-rail intersection that may include direction and allow calculation of approximate arrival time and closure duration.
- b) **Conflict Monitor Status:** A control flow that supports failsafe operation in the event that a conflict is detected that requires the RSE to enter a failsafe operating mode.
- c) **Intersection Control Status:** Status data provided by the traffic signal controller including phase information, alarm status, and priority/preempt status.
- d) **Intersection Infringement Info:** Vehicle path information sent by a vehicle that is violating the stop bar at an intersection. This flow includes the vehicle's position, heading, speed, acceleration, transmission, steering-wheel angle, braking status, size information, and trajectory.
- e) **Intersection Status Monitoring:** Current signal phase and timing information for all lanes at a signalized intersection. This flow identifies monitoring of communications by a receiver at the intersection to support monitoring for conflicts between actual signal states and RSE communications about those states.
- f) **Mixed Use Crossing Status:** Current pedestrian and other non-motorized user locations including an indication of whether the call button has been activated, the current state of the mixed-use crossing signal, and information indicating whether non-motorized users are currently occupying the cross walk.
- g) **Personal Location Information:** Pedestrian, bicyclist, and other non-motorized user locations at an intersection as detected and reported by an RSE.
- h) **Signal Preemption Request:** Direct request for preemption to a traffic signal controller that results in preemption of the current control plan and grants right-of-way to the requesting vehicle. This flow identifies the required phase and timing of the preemption. This flow may also cancel the preemption request (e.g., when the requesting vehicle clears the intersection).
- i) **Signal Service Request:** A call for service or extension for a signal control phase that is issued by the RSE for connected vehicles approaching an intersection and/or pedestrians at a crosswalk. This flow identifies the desired phase and service time.
- j) **Track Status:** Current status of the wayside equipment and notification of an arriving train.
- k) **Traffic Situation Data:** Current, aggregate traffic data collected from connected vehicles that can be used to supplement or replace information collected by roadside traffic detectors. It includes

raw and/or processed reported vehicle speeds, counts, and other derived measures. Raw and/or filtered vehicle control events may also be included to support incident detection.

- l) **Vehicle Entries and Exit:** Information exchanged between an RSE and ITS Roadway Equipment (ASC) that supports detection of non-equipped vehicles in an automated lane, low emissions zone, or other facility where V2I communications is used to monitor vehicles at entry or exit points. This exchange also supports identification of non-equipped vehicles where an RSE is used for payment collection. This generic exchange can be implemented by any approach that compares vehicle detections with V2I communications by the RSE to identify vehicles that are not equipped or are otherwise unable to communicate with the RSE.

Section 3

Functional Requirements [Normative]

Section 3 defines the Functional Requirements based on the user needs identified in the Concept of Operations (see Section 2). Section 3 includes:

- a) A tutorial
- b) Protocol Requirements List (PRL) – A Functional Requirement is a requirement of a given function and therefore is only required to be implemented if the associated functionality (e.g., user need) is selected through the use of the PRL. The PRL also indicates which of the items are mandatory, conditional, or optional. The PRL can be used by procurement personnel to specify the desired features of an ASC system or can be used by a manufacturer to document the features supported by their implementation.
- c) Architectural Requirements – These are requirements related to the architectural needs defined in Section 2.4.
- d) Data Exchange and Operational Environment Requirements – These are requirements related to the features identified in Section 2.5 that can be realized through a data exchange. For example, this includes the requirement to be able to monitor what signal indications are active.
- e) Supplemental Non-communications Requirements – These are additional requirements derived from the Concept of Operations that do not fall into one of the above two categories. For example, they include requirements related to performance requirements.
- f) Generic Requirements – There are requirements that are generic to all NTCIP field devices. For example, clock synchronization of devices is a requirement that is considered generic to all NTCIP devices. These requirements can be found in Annex G.

Section 3 is intended for all readers, including:

- a) Transportation operations managers
- b) Transportation operations personnel
- c) Transportation engineers
- d) System integrators
- e) Device manufacturers

For the first three categories of readers, Section 3 is useful in understanding the details that NTCIP 1202 v04 requires of an ASC. For these readers, Section 3.3.3 is particularly useful in preparing procurement specifications and assist in mapping the various rows of this table to the more detailed text contained within the other sections.

For the last two categories of readers, this section is useful to fully understand what is required of equipment meeting this interface standard. The table in Section 3.3.3 may be used to document the capabilities of their implementations.

3.1 Tutorial [Informative]

This Functional Requirements section defines the formal requirements that are intended to satisfy the user needs identified in Section 2. This is achieved through the development of a PRL that traces each user need to one or more requirements defined in this section. The details of each requirement are then presented following the PRL. The functional requirements are presented in three broad categories as follows:

- a) Architectural Requirements – These requirements define the required behavior of the system in exchanging data across the communications interface, including any restrictions to general architectural requirements, based upon the architectural needs identified in the Concept of Operations.
- b) Data Exchange Requirements – These requirements define the required behavior of the system in exchanging data across the communications interface based upon the features identified in the Concept of Operations.
- c) Supplemental Requirements – These requirements define additional requirements of the system that are derived from the architectural and/or data exchange requirements, but are not themselves architectural or data exchange requirements. A given supplemental requirement may relate to multiple architectural and/or data exchange requirements. Supplemental requirements include capabilities of the equipment (e.g., service processing or clearing expired priority requests).

3.2 Scope Of The Interface [Informative]

<In the opinion of the responsible NTCIP working group, this section does not apply in the context of NTCIP 1202 v04.>

3.3 Protocol Requirements List (PRL)

The PRL, provided in Table 5 defined in Section 3.3.3, maps the user needs defined in Section 2 to the requirements defined in Section 3. The PRL can be used by:

- a) A user or specification writer to indicate which requirements are to be implemented in a project-specific implementation.
- b) The protocol implementer, as a checklist to reduce the risk of failure to conform to the standard through oversight.
- c) The supplier and user, as a detailed indication of the capabilities of the implementation.
- d) The user, as a basis for initially checking the potential interoperability with another implementation.

3.3.1 Notation [Informative]

The following notations and symbols are used to indicate status and conditional status in the PRL within all NTCIP standards. Not all of these notations and symbols may be used within NTCIP 1202 v04.

3.3.1.1 Conformance Symbols

The symbols in Table 1 are used to indicate status under the Conformance column in the PRL.

Table 1 Conformance Symbols

Symbol	Status
M	Mandatory
M.#	Support of every item of the group labeled by the same numeral # is required, but only one is active at a time
O	Optional
O.# (range)	Part of an option group. Support of the number of items indicated by the '(range)' is required from all options labeled with the same numeral #
C	Conditional
NA	Not-applicable (i.e., logically impossible in the scope of the standard)
X	Excluded or prohibited

The O.# (range) notation is used to show a set of selectable options (e.g., O.2 (1..*) would indicate that one or more of the option group 2 options shall be implemented). Two character combinations are used for dynamic requirements. In this case, the first character refers to the static (implementation) status, and the second refers to the dynamic (use); thus, "MO" means "mandatory to be implemented, optional to be used."

3.3.1.2 Conditional Status Notation

The predicate notations in Table 2 may be used.

Table 2 Conditional Status Notation

Predicate	Notation
<predicate>:	This notation introduces a single item that is conditional on the <predicate>.
<predicate>::	This notation introduces a table or a group of tables, all of which are conditional on the <predicate>.
(predicate)	This notation introduces the first occurrence of the predicate. The feature associated with this notation is the base feature for all options that have this predicate in their conformance column.

The <predicate>: notation means that the status following it applies only when the PRL states that the feature or features identified by the predicate are supported. In the simplest case, <predicate> is the identifying tag of a single PRL item. The <predicate> notation may precede a table or group of tables in a section or subsection. When the group predicate is true then the associated section shall be completed. The symbol <predicate> also may be a Boolean expression composed of several indices. "AND," "OR," and "NOT" shall be used to indicate the Boolean logical operations.

The predicates used in NTCIP 1202 v04 map to the sections indicated in Table 3.

Table 3 Predicate Mapping to NTCIP 1202 v04 Section

Predicate	Section
332	2.3.1.a
ATC	2.3.1.e
BackupUD	3.5.2.1.1.2.2
Coord	2.5.2.1.3
Channel	2.5.2.1.7
CV	2.5.4
Detector	2.5.3.1
Dimming	3.5.2.2.2.1.3
DynOb	ISO 26048-1§ 8.8.2.1
Generator	ISO 26048-1§ 8.2.2.2.1.c
Overlap	2.5.2.1.8
MvtConflict	3.5.4.1.3.3.3.2
MvtQueue	3.5.4.1.3.3.3.1
PhsCtrl	2.5.2.3.3
Power	2.5.1.4
Preempt	2.5.2.1.9
preemptExit	3.5.2.1.9.1.12.1
Queue	ISO 26048-1§ 8.10.1.3.3.2
Ring	2.5.2.1.6
Scheduler	2.5.2.1.10
SetDynObj	ISO 26048-1§ 8.8.3.5

Predicate	Section
Solar	ISO 26048-1§ 8.2.2.2.1.d
SpdAdvice	3.5.4.1.3.3.4.1
SpecialFunc	2.5.2.2.9
Traps	2.4.5
TS1	2.3.1.b
TS2-1	2.3.1.d
TS2-2	2.3.1.c
TwoStep	ISO 26048-1§ 8.8.3.6
Unit	2.5.2.2.2.1
UPS	ISO 26048-1§ 8.2.2.2.1.b or ISO 26048-1§ 8.2.2.2.2

3.3.1.3 Support Column Symbols

The Support column in the PRL can be used by a procurement specification to identify the required features for the given procurement or by an implementer to identify which features have been implemented. In either case, the user circles the appropriate answer (Yes, No, or N/A) in the support column:

Table 4 Support Column Entries

Entry	Identifier
Yes	Supported by the implementation.
No	Not supported by the implementation.
N/A	Not applicable

3.3.2 Instructions for Completing the PRL [Informative]

In the 'Support' column, each response shall be selected either from the indicated set of responses (for example: Yes / No / NA), or it shall reference additional items that are to be attached (for example, list of traffic signal controllers to be supported by an implementation).

If a conditional requirement is inapplicable, use the Not Applicable (NA) choice. If a mandatory requirement is not satisfied, exception information shall be supplied by entering a reference Xi, where i is a unique identifier, to an accompanying rationale for the non-conformance. When the status is expressed as a two-character combination (as defined in 3.3.1.1 above), the response shall address each element of the requirement; e.g., for the requirement "mo," the possible compliant responses are "yy" or "yn."

Note: A specification can allow for flexibility in a deliverable by leaving the selection in the Support column blank for a given row.

3.3.2.1 Conformance Definition

To claim "Conformance" to NTCIP 1202 v04, the vendor shall minimally fulfill the mandatory requirements as identified in the PRL table (see Table 5).

Note: The reader and user of NTCIP 1202 v04 are advised that 'conformance' to NTCIP 1202 v04 should not be confused with 'compliance' to a specification. NTCIP 1202 v04 is as broad as possible to allow a very simple ASC implementation to be 'conformant' to NTCIP 1202 v04. An agency specification needs to identify the requirements of a particular project and needs to require the support of those requirements. A specification writer is advised to match the requirements of a project with the corresponding standardized requirements defined in NTCIP 1202 v04 to achieve interoperability. This means that functions and requirements defined as 'optional' in NTCIP 1202 v04 might need to be selected in a specification (in effect made 'mandatory' for the project-specific specification).

A conformant device may offer additional (optional) features, as long as they are conformant with the requirements of NTCIP 1202 v04 and the standards it references (e.g., NTCIP 1201 v03 and NTCIP 2301 v02). For example, to claim conformance to additional features, an implementation shall conform to all of the mandatory and selected optional requirements that trace to the subject user needs in the PRL, AND shall fulfill the requirement by using all of the dialogs and data elements traced to the subject requirement in the Requirements Traceability Matrix (RTM) in Annex A.

A device may also support data that has not been defined by NTCIP 1202 v04; however, when exchanged via one of the NTCIP 2301 v02 protocols, the data shall be properly registered with a valid OBJECT IDENTIFIER under the Global ISO Naming Tree.

Note: Off-the-shelf interoperability and interchangeability can only be obtained through well-documented features broadly supported by the industry as a whole. Designing a system that uses features not defined in a standard or not typically deployed in combination with one another inhibits the goals of interoperability and interchangeability, especially if the documentation of these features is not available for distribution to system integrators. Standards allow the use of additional features to support innovation, which is constantly needed within the industry; but users should be aware of the risks involved with using such features.

To claim "Conformance" to NTCIP 1202 v04, an ASC device shall be provided with a MIB that contains all non-NTCIP-standardized (including custom, proprietary and vendor-, agency-, or implementation-specific) object and block definitions. Object and block definitions contained in the MIB shall:

- a) use the ASN.1 notation and conventions used in NTCIP 1202 v04 standardized object and block definitions,
- b) include non-NTCIP-standardized enumerations, and
- c) include meaningful, human-understandable, English language DESCRIPTION fields including descriptions of the object and all supported values.

In addition, to claim "Conformance" to NTCIP 1202 v04, an ASC device shall use the NTCIP 1202 v04 standardized objects to manage NTCIP 1202 v04 functionality. Non-NTCIP-standardized objects may be used to manage NTCIP 1202 v04 functionality only if NTCIP 1202 v04 standardized objects for the same functions are also supported. ASC devices or systems attempting to manage, configure, or monitor an NTCIP 1202 v04 standardized object shall not be required to use proprietary objects for NTCIP 1202 v04 functionality.

3.3.3 Protocol Requirements List (PRL) Table

In addition to the Conformance column and the Support column, which were discussed in Sections 3.3.1 and 3.3.2, the additional columns in the PRL table are the User Need ID and User Need columns, FR ID and Functional Requirements columns and the Additional Specifications column.

- a) User Need ID – the number assigned to the user need statement. The user needs are defined within Section 2, and the PRL is based upon the user need sections within that Section.
- b) User Need – a short descriptive title identifying the user need.
- c) FR ID – the number assigned to the functional requirement statement. The requirements are defined within Section 3, and the PRL references the traces from user needs to these requirements.
- d) Functional Requirement – a short descriptive title identifying the functional requirement.
- e) Additional Specifications – identifies other requirements to satisfy, including user selectable range values. The "Additional Specifications" column may (and should) be used by a procurement specification to provide additional notes and requirements for the product to be procured or may be used by an implementer to provide any additional details about the implementation. In some cases, default text already exists in this field, which the user should complete to fully specify the

equipment. However, additional text can be added to this field as needed to fully specify a feature.

Note: Visit www.ntcip.org for information on the availability of electronic copies of the PRL.

Table 5 Protocol Requirements List (PRL)

Protocol Requirements List (PRL)						
User Need ID	User Need	FR ID	Functional Requirement	Conformance	Support	Additional Specifications
2.3	Reference Physical Architecture [Informative]					
2.3.1	ASC Characteristics – Cabinet Specifications			M	Yes	
2.3.1.a (332)	Model 332 Cabinet			O.1 (1)	Yes / No	
2.3.1.b (TS1)	NEMA TS 1 Cabinet			O.1 (1)	Yes / No	
2.3.1.c (TS2-2)	NEMA TS 2 Type 2 Cabinet			O.1 (1)	Yes / No	
2.3.1.d (TS2-1)	NEMA TS 2 Type 1 Cabinet			O.1 (1)	Yes / No	
2.3.1.e (ATC)	ATC Cabinet			O.1 (1)	Yes / No	
2.3.2	ASC Characteristics – Controller Types			M	Yes	
2.3.2.a	Phase-based controller			M	Yes	
2.3.2.b	Interval-based controller			NA	NA	Interval-based controllers are not supported by NTCIP 1202 v04
2.3.2.c	Stage-based controller			NA	NA	Stage-based controllers are not supported by NTCIP 1202 v04
2.4	Architectural Needs					
2.4.1	Provide Live Data			M	Yes	
	3.4.1.1	Retrieve Data		M	Yes	
	3.4.1.2	Deliver Data		M	Yes	
	3.4.1.3	Explore Data		M	Yes	
	3.4.1.4.1	Monitor SNMP Information		M	Yes	
	ISO 26048-1§ 8.6.2.6	Determine basic capabilities of the controller		M	Yes	
	ISO 26048-1§ 8.6.2.7	Determine SNMP capabilities of the controller		M	Yes	
	ISO 26048-1§ 8.6.2.8	Determine the SNMP engine identifier		M	Yes	
	ISO 26048-1§ 8.6.2.9	Monitor when the SNMP capabilities last changed		M	Yes	

Protocol Requirements List (PRL)						
User Need ID	User Need	FR ID	Functional Requirement	Conformance	Support	Additional Specifications
		ISO 26048-1§ 8.6.6	Controller performance requirements	M	Yes	
		3.6.1	Response Time for Requests	M	Yes	The Response Time for all requests shall be ____ milliseconds (5-500: Default=25).
		3.6.2	Atomic Operations	M	Yes	
2.4.2	Provide Pre-Defined Data Blocks			O	Yes / No	
		3.4.2.1	Store Pre-defined Compressed Data Blocks	O.2 (1..*)	Yes / No	
		ISO 26048-1§ 8.8.2.1 (DynOb)	Change status of dynamic object	O.2 (1..*)	Yes / No	
		ISO 26048-1§ 8.8.2.2	Configure dynamic object owner	DynOb:M	Yes / NA	
		ISO 26048-1§ 8.8.2.3	Configure dynamic object	DynOb:M	Yes / NA	
		ISO 26048-1§ 8.8.2.4	Configure dynamic object field	DynOb:M	Yes / NA	
		ISO 26048-1§ 8.8.2.5	Confirm dynamic object owner configuration	DynOb:M	Yes / NA	Not necessary. Delete.
		ISO 26048-1§ 8.8.2.6	Confirm dynamic object configuration	DynOb:M	Yes / NA	Not necessary. Delete.
		ISO 26048-1§ 8.8.2.8	Determine administrative capabilities for dynamic object	DynOb:M	Yes / NA	*Note-numbering is incorrect in ISO 26048-1.
		ISO 26048-1§ 8.8.2.9	Determine dynamic object capabilities	DynOb:M	Yes / NA	
		ISO 26048-1§ 8.8.2.10	Monitor statistics for dynamic object owner	DynOb:M	Yes / NA	
		ISO 26048-1§ 8.8.2.11	Monitor statistics for dynamic object	DynOb:M	Yes / NA	
		ISO 26048-1§ 8.8.2.12	Obtain dynamic object data in one step	DynOb:M	Yes / NA	
		ISO 26048-1§ 8.8.2.13	Obtain dynamic object data in two steps	TwoStep:M	Yes / NA	

Protocol Requirements List (PRL)						
User Need ID	User Need	FR ID	Functional Requirement	Conformance	Support	Additional Specifications
		ISO 26048-1§ 8.8.2.14	Retrieve the last dynamic object value set	DynOb:M	Yes / NA	
		ISO 26048-1§ 8.8.2.15	Set new value for dynamic object in one step	SetDynObj:M	Yes / NA	
		ISO 26048-1§ 8.8.2.16	Set new value for dynamic object in two steps	SetDynObj, TwoStep:M	Yes / NA	
		ISO 26048-1§ 8.8.3.1	Number of referenced objects	DynOb:M	Yes / NA	
		ISO 26048-1§ 8.8.3.2	Dynamic object variable bindings size	DynOb:M	Yes / NA	
		ISO 26048-1§ 8.8.3.3	Support dynamic object with basic encoding rules	DynOb:M	Yes / NA	
		ISO 26048-1§ 8.8.3.4	Support dynamic object with octet encoding rules	DynOb:O	Yes / No / NA	
		ISO 26048-1§ 8.8.3.5 (SetDynObj)	Support of set operations on dynamic objects	DynOb:O	Yes / No / NA	
		ISO 26048-1§ 8.8.3.6 (TwoStep)	Support for dynamic objects that use a two-step process	DynOb:O	Yes / No / NA	
		ISO 26048-1§ 8.8.3.7	Dynamic object feature functional requirements	DynOb:M	Yes / NA	
2.4.3	Provide for Log Data Local Storage and Retrieval			O	Yes / No	
		ISO 26048-1§ 8.9.2.1	Change status of log class	M	Yes	
		ISO 26048-1§ 8.9.2.2	Change status of log snapshot factory	M	Yes	
		ISO 26048-1§ 8.9.2.3	Configure log owner	M	Yes	
		ISO 26048-1§ 8.9.2.4	Configure log class	M	Yes	
		ISO 26048-1§ 8.9.2.5	Configure log snapshot factory	M	Yes	
		ISO 26048-1§ 8.9.2.6	Confirm log owner configuration	M	Yes	Not necessary. Delete.

Protocol Requirements List (PRL)						
User Need ID	User Need	FR ID	Functional Requirement	Conformance	Support	Additional Specifications
		ISO 26048-1§ 8.9.2.7	Confirm log class configuration	M	Yes	Not necessary. Delete.
		ISO 26048-1§ 8.9.2.8	Confirm log snapshot factory configuration	M	Yes	Not necessary. Delete.
		ISO 26048-1§ 8.9.2.9	Clear old snapshots from log	M	Yes	
		ISO 26048-1§ 8.9.2.10	Clear all log classes	M	Yes	
		ISO 26048-1§ 8.9.2.11	Clear logs of an owner	M	Yes	
		ISO 26048-1§ 8.9.2.12	Delete a log class	M	Yes	
		ISO 26048-1§ 8.9.2.13	Delete all log classes	M	Yes	
		ISO 26048-1§ 8.9.2.14	Delete all log classes of an owner	M	Yes	
		ISO 26048-1§ 8.9.2.15	Delete log snapshot factory	M	Yes	
		ISO 26048-1§ 8.9.2.16	Determine log capabilities	M	Yes	
		ISO 26048-1§ 8.9.2.17	Monitor log class summary statistics	M	Yes	
		ISO 26048-1§ 8.9.2.18	Monitor log statistics for an owner	M	Yes	
		ISO 26048-1§ 8.9.2.19	Monitor log class statistics	M	Yes	
		ISO 26048-1§ 8.9.2.20	Monitor log class status	M	Yes	
		ISO 26048-1§ 8.9.2.21	Obtain logged snapshot	M	Yes	
		ISO 26048-1§ 8.9.3.1	Maximum data size	M	Yes	
		ISO 26048-1§ 8.9.3.2	Latency of snapshot logging	M	Yes	
		2.4.4	Provide for Database Management			M

Protocol Requirements List (PRL)						
User Need ID	User Need	FR ID	Functional Requirement	Conformance	Support	Additional Specifications
		ISO 26048-1§ 8.16.2.1	Control initiation of database transaction mode	M	Yes	
		ISO 26048-1§ 8.16.2.2	Control completion of database transaction mode	M	Yes	
		ISO 26048-1§ 8.16.2.3	Control a forced reset of database transaction mode	M	Yes	
		ISO 26048-1§ 8.16.2.4	Obtain current database transaction mode	M	Yes	
		ISO 26048-1§ 8.16.3.1	Enforce interrelated parameter restrictions	M	Yes	
		ISO 26048-1§ 8.16.3.2	Buffer parameter changes when in transaction	M	Yes	
2.4.5 (Traps)	Condition-based Exception Reporting			O	Yes / No	
		ISO 26048-1§ 8.10.1.2.1	Change enabled status for all notifications	M	Yes	
		ISO 26048-1§ 8.10.1.2.2	Change status of notification factory	M	Yes	Not in the NRTM.
		ISO 26048-1§ 8.10.1.2.3	Configure notification owner	M	Yes	Not in the NRTM.
		ISO 26048-1§ 8.10.1.2.4	Configure a notification channel	M	Yes	
		ISO 26048-1§ 8.10.1.2.5	Configure a notification factory	M	Yes	
		ISO 26048-1§ 8.10.1.2.6	Confirm notification owner configuration	M	Yes	Not necessary. Delete.
		ISO 26048-1§ 8.10.1.2.7	Confirm notification channel configuration	M	Yes	Not necessary. Delete.
		ISO 26048-1§ 8.10.1.2.8	Confirm notification factory configuration	M	Yes	Not necessary. Delete.
		ISO 26048-1§ 8.10.1.2.9	Clear notification channel queue	M	Yes	
		ISO 26048-1§ 8.10.1.2.10	Delete a notification channel	M	Yes	
		ISO 26048-1§ 8.10.1.2.11	Delete notification factory	M	Yes	

Protocol Requirements List (PRL)						
User Need ID	User Need	FR ID	Functional Requirement	Conformance	Support	Additional Specifications
		ISO 26048-1§ 8.10.1.2.12	Determine notification factory capabilities	M	Yes	
		ISO 26048-1§ 8.10.1.2.13	Monitor administrative notification statistics	O	Yes / No	Not in the NRTM.
		ISO 26048-1§ 8.10.1.2.14	Monitor notification owner statistics	O	Yes / No	Not in the NRTM.
		ISO 26048-1§ 8.10.1.2.15	Monitor notification channel statistics	M	Yes	
		ISO 26048-1§ 8.10.1.2.16	Monitor notification factory statistics	O	Yes / No	Not in the NRTM.
		ISO 26048-1§ 8.10.1.2.17	Retrieve last notification contents	O	Yes / No	Not in the NRTM.
		ISO 26048-1§ 8.10.1.2.18	Send notifications to SNMP target	M	Yes	
		ISO 26048-1§ 8.10.1.3.1	Notification packet size	M	Yes	
		ISO 26048-1§ 8.10.1.3.2.1	Support for unacknowledged notifications	M	Yes	Not in the NRTM.
		ISO 26048-1§ 8.10.1.3.2.2	Support for acknowledged notifications	O	Yes / No	Not in the NRTM.
		ISO 26048-1§ 8.10.1.3.3.1	Support non-queueable notifications	M	Yes	Not in the NRTM.
		ISO 26048-1§ 8.10.1.3.3.2 (Queue)	Support for queueable notifications	O	Yes / No	Not in the NRTM.
		ISO 26048-1§ 8.10.1.4.1	Generate a notification	M	Yes	Not in the NRTM.
		ISO 26048-1§ 8.10.1.4.2	Process incoming data	Queue:M	Yes	
		ISO 26048-1§ 8.10.1.4.3	Sending non-queueable notifications	Queue:M	Yes	
		ISO 26048-1§ 8.10.1.4.4	Sending queueable notifications	M	Yes	
		ISO 26048-1§ 8.10.1.4.5	Adding messages to the notification queue	M	Yes	
2.5	Features					

Protocol Requirements List (PRL)						
User Need ID	User Need	FR ID	Functional Requirement	Conformance	Support	Additional Specifications
2.5.1	Manage the ASC Configuration			M	Yes	
2.5.1.1	Manage Device Identity			M	Yes	
		3.5.1.1.1	Configure ASC Location	O	Yes / No	Only needed if no external GNSS device is attached to the ASC
		3.5.1.1.2	Configure ASC Location - Antenna Offset	O	Yes / No	Only needed if an external GNSS device is attached to the ASC
		3.5.1.1.3	Determine Supported Standards	M	Yes	
		ISO 26048-1§ 8.2.2.1.1	Configure the cabinet's location	M	Yes	Note: the objects are read-only (fdCabinetLatitude, fdCabinetLongitude, fdCabinetElevation)
		ISO 26048-1§ 8.2.2.1.2	Configure the cabinet's physical components	M	Yes	
		ISO 26048-1§ 8.2.2.1.3	Confirm the cabinet's location	M	Yes	Not necessary. Delete.
		ISO 26048-1§ 8.6.2.1	Configure the controller's identity	M	Yes	
		ISO 26048-1§ 8.6.2.2	Configure the default language	M	Yes	
		ISO 26048-1§ 8.6.2.3	Confirm the controller's identity	M	Yes	Not necessary. Delete.
		ISO 26048-1§ 8.6.2.4	Confirm the current default language configuration	M	Yes	Not necessary. Delete.
		ISO 26048-1§ 8.6.2.5	Control remote reset of the controller	M	Yes	
		ISO 26048-1§ 8.6.2.13	Obtain the field device configuration identifier	M	Yes	
		ISO 26048-1§ 8.6.3.1	Support maximum message size	M	Yes	
		ISO 26048-1§ 8.6.3.2	Support changeable memory	O.3 (0..*)	Yes / No	
		ISO 26048-1§ 8.6.3.3	Support volatile memory	O.3 (0..*)	Yes / No	

Protocol Requirements List (PRL)						
User Need ID	User Need	FR ID	Functional Requirement	Conformance	Support	Additional Specifications
		ISO 26048-1§ 8.6.4	Controller feature design constraints	M	Yes	Note: no design trace
		ISO 26048-1§ 8.6.5	Controller feature functional requirements	M	Yes	Note: no design trace
		ISO 26048-1§ 8.11.2.1	Change status of owner	M	Yes	
		ISO 26048-1§ 8.11.2.2	Configure owner	M	Yes	
		ISO 26048-1§ 8.11.2.3	Confirm owner configuration	M	Yes	Not necessary. Delete.
2.5.1.2	Manage Communications			O	Yes / No	Propose to delete.
		3.5.1.2.1.1	Enable/Disable Communications Port	M	Yes	The ASC shall not be allowed to enable/disable the following ports numbers: _____
		3.5.1.2.1.2	Configure ASC Ethernet Ports	O	Yes / No	The ASC shall not be allowed to configure the following ports: _____
		3.5.1.2.1.3	Configure ASC Asynchronous Serial Ports	O	Yes / No	The ASC shall not be allowed to configure the following ports: _____
		3.5.1.2.1.4	Configure ASC Synchronous Serial Ports	O	Yes / No	The ASC shall not be allowed to configure the following ports: _____
		3.5.1.2.1.5	Configure ASC Communications Protocol - Serial Ports	O	Yes / No	The ASC shall not be allowed to configure the following ports: _____
2.5.1.3	Manage Cabinet Environment			O	Yes / No	
		3.5.1.3.1	Configure ATC Cabinet Device LEDs	ATC:O	Yes / No	
		ISO 26048-1§ 8.2.2.1.2	Configure the cabinet's physical components	M	Yes	

Protocol Requirements List (PRL)						
User Need ID	User Need	FR ID	Functional Requirement	Conformance	Support	Additional Specifications
		ISO 26048-1§ 8.2.2.1.4	Confirm the cabinet's physical components	M	Yes	Not necessary. Delete.
		ISO 26048-1§ 8.2.4.3.1	Cabinet doors monitored	M	Yes	Minimum number of doors to be supported (Default: 2) ____
		ISO 26048-1§ 8.2.4.4.1	Cabinet doors monitored through RSA	M	Yes	
		ISO 26048-1§ 8.2.5.3.1	Cabinet fans actively monitored	M	Yes	Minimum number of fans supported (Default: 2) ____
		ISO 26048-1§ 8.2.5.3.2	Cabinet fan control	O	Yes / No	
		ISO 26048-1§ 8.2.5.4.1	Cabinet fans managed through RSA	M	Yes	
		ISO 26048-1§ 8.2.7.3.1	Cabinet heaters actively monitored	M	Yes	Minimum number of heaters supported (Default: 1) ____
		ISO 26048-1§ 8.2.7.3.2	Cabinet heater control	O	Yes / No	
		ISO 26048-1§ 8.2.7.4.1	Cabinet heaters managed through RSA	M	Yes	
		ISO 26048-1§ 8.2.8.3.1	Cabinet humidity monitored	M	Yes	Minimum number of humidity sensors supported (Default: 1) ____
		ISO 26048-1§ 8.2.8.4.1	Cabinet humidity monitored through RSA	M	Yes	A value less than the minimum threshold or greater than the maximum threshold will enable an alarm bit. Minimum Threshold (Default: -127) ____ Maximum Threshold (Default: 127) ____ Unit of Measure (Default: degrees Celsius) ____
		ISO 26048-1§ 8.2.11.3.1	Cabinet temperature monitored	M	Yes	Minimum number of temperature sensors supported (Default: 1) ____

Protocol Requirements List (PRL)						
User Need ID	User Need	FR ID	Functional Requirement	Conformance	Support	Additional Specifications
		ISO 26048-1§ 8.2.11.4.1	Cabinet temperature monitored through RSA	M	Yes	A value less than the minimum threshold or greater than the maximum threshold will enable an alarm bit. Minimum Threshold (Default: 0) _____ Maximum Threshold (Default: 100) _____ Unit of Measure (Default: %) _____
2.5.1.4 (Power)	Monitor Power			O	Yes / No	
		3.5.1.4.1	Determine Power Source	M	Yes	Note: 26048 does not support 48Vdc or 24 Vdc.
		ISO 26048-1§ 8.2.2.1.5	Monitor current power source	M	Yes	Note: 26048 does not support 48Vdc or 24 Vdc.
		ISO 26048-1§ 8.2.2.2.1.a	Support power sources – mainline (alternating current) power	M	Yes	
		ISO 26048-1§ 8.2.2.2.1.b (UPS)	Support power sources – battery power	O	Yes / No	
		ISO 26048-1§ 8.2.2.2.1.c (Generator)	Support power sources – generator power	O	Yes / No	
		ISO 26048-1§ 8.2.2.2.1.d (Solar)	Support power sources – solar power	O	Yes / No	
		ISO 26048-1§ 8.2.2.2.2 (UPS)	Support UPS power	O	Yes / No	Redundant with ISO 26048-1§ 8.2.2.2.1.b
		ISO 26048-1§ 8.2.3.3.1	Cabinet battery voltage	UPS:M	Yes / NA	Minimum number of voltage sensors for the cabinet battery supported (Default: 1) _____
		ISO 26048-1§ 8.2.3.3.2	Cabinet battery current	UPS:M	Yes / NA	Minimum number of current sensors for the cabinet battery supported (Default: 1) _____

Protocol Requirements List (PRL)						
User Need ID	User Need	FR ID	Functional Requirement	Conformance	Support	Additional Specifications
		ISO 26048-1§ 8.2.3.3.3	Cabinet battery charge	UPS:M	Yes / NA	Minimum number of charge sensors for the cabinet battery supported (Default: 1) _____
		ISO 26048-1§ 8.2.3.4.1	Cabinet battery voltage monitored through RSA	UPS:M	Yes / NA	1202 v03: 0.0 vDC to 100.0 vDC in units of 0.1 vDC.
		ISO 26048-1§ 8.2.3.4.2	Cabinet battery current monitored through RSA	UPS:M	Yes / NA	1202 v03: 0.0 to 20.0 RSM Amp DC in units of 0.1 Amp DC
		ISO 26048-1§ 8.2.3.4.3	Cabinet battery charge monitored through RSA	UPS:M	Yes / NA	1202 v03: 0 to 100 percent, in units of 1%.
		ISO 26048-1§ 8.2.6.3.1	Cabinet generator voltage	Generator:M	Yes / NA	Minimum number of voltage sensors for the cabinet generator supported (Default: 1) _____
		ISO 26048-1§ 8.2.6.3.2	Cabinet generator current	Generator:M	Yes / NA	Minimum number of current sensors for the cabinet generator supported (Default: 1) _____
		ISO 26048-1§ 8.2.6.3.3	Cabinet generator engine speed	Generator:M	Yes / NA	Minimum number of engine speed sensors for the cabinet generator supported (Default: 1) _____
		ISO 26048-1§ 8.2.6.3.4	Cabinet generator fuel level	Generator:M	Yes / NA	Minimum number of fuel level sensors for the cabinet generator supported (Default: 1) _____
		ISO 26048-1§ 8.2.6.4.1	Cabinet generator voltage monitored through RSA	Generator:M	Yes / NA	
		ISO 26048-1§ 8.2.6.4.2	Cabinet generator current monitored through RSA	Generator:M	Yes / NA	
		ISO 26048-1§ 8.2.6.4.3	Cabinet generator engine speed monitored through RSA	Generator:M	Yes / NA	
		ISO 26048-1§ 8.2.6.4.4	Cabinet generator fuel level monitored through RSA	Generator:M	Yes / NA	

Protocol Requirements List (PRL)						
User Need ID	User Need	FR ID	Functional Requirement	Conformance	Support	Additional Specifications
		ISO 26048-1§ 8.2.9.3.1	Cabinet mains power voltage	M	Yes	Minimum number of voltage sensors for the cabinet mains power supported (Default: 1) _____
		ISO 26048-1§ 8.2.9.3.2	Cabinet mains power current	M	Yes	Minimum number of current sensors for the cabinet mains power supported (Default: 1) _____
		ISO 26048-1§ 8.2.9.4.1	Cabinet mains power voltage monitored through RSA	M	Yes	1202 v03: 0.0 to 600 vAC, in 0.1 RMS volt units.
		ISO 26048-1§ 8.2.9.4.2	Cabinet mains power current monitored through RSA	M	Yes	
		ISO 26048-1§ 8.2.10.3.1	Cabinet solar power voltage	Solar:M	Yes / NA	Minimum number of voltage sensors for the cabinet solar power system supported (Default: 1) _____
		ISO 26048-1§ 8.2.10.3.2	Cabinet solar power current	Solar:M	Yes / NA	Minimum number of current sensors for the solar power system supported (Default: 1) _____
		ISO 26048-1§ 8.2.9.4.1	Cabinet solar power voltage monitored through RSA	Solar:M	Yes / NA	
		ISO 26048-1§ 8.2.9.4.2	Cabinet solar power current monitored through RSA	Solar:M	Yes / NA	
2.5.1.5	Retrieve Operational Performance Data			O	Yes / No	
		ISO 26048-1§ 8.12.2.1	Configure an owner for recordings	M	Yes	
		ISO 26048-1§ 8.12.2.2	Configure a recording class	M	Yes	
		ISO 26048-1§ 8.12.2.3	Configure a recording factory	M	Yes	
		ISO 26048-1§ 8.12.2.4	Confirm recording owner configuration	M	Yes	
		ISO 26048-1§ 8.12.2.5	Confirm recording class configuration	M	Yes	

Protocol Requirements List (PRL)						
User Need ID	User Need	FR ID	Functional Requirement	Conformance	Support	Additional Specifications
		ISO 26048-1§ 8.12.2.6	Confirm recording factory configuration	M	Yes	
		ISO 26048-1§ 8.12.2.7	Clear all recordings configuration	M	Yes	
		ISO 26048-1§ 8.12.2.8	Clear all recording classes	M	Yes	
		ISO 26048-1§ 8.12.2.9	Clear all recording factories	M	Yes	
		ISO 26048-1§ 8.12.2.10	Clear all recording classes for owner	M	Yes	
		ISO 26048-1§ 8.12.2.11	Clear all recording factories for owner	M	Yes	
		ISO 26048-1§ 8.12.2.12	Clear all recordings for owner	M	Yes	
		ISO 26048-1§ 8.12.2.13	Clear all recordings in a class	M	Yes	
		ISO 26048-1§ 8.12.2.14	Determine recording capabilities	M	Yes	
		ISO 26048-1§ 8.12.2.15	Monitor total number of recordings	M	Yes	
		ISO 26048-1§ 8.12.2.16	Monitor number of recordings for an owner	M	Yes	
		ISO 26048-1§ 8.12.2.17	Monitor number of recordings within a class	M	Yes	
		ISO 26048-1§ 8.12.2.18	Retrieve recording meta-data	M	Yes	
		ISO 26048-1§ 8.12.2.19	Retrieve a recording sample	M	Yes	
		ISO 26048-1§ 8.12.3.1	Support a Number of Recording Classes	M	Yes	
		ISO 26048-1§ 8.12.3.2	Support a Number of Recordings to Store in Log	M	Yes	
		ISO 26048-1§ 8.12.3.3	Support a Number of Events within a Recording	M	Yes	
		ISO 26048-1§ 8.12.4	Recording feature functional requirement	M	Yes	

Protocol Requirements List (PRL)						
User Need ID	User Need	FR ID	Functional Requirement	Conformance	Support	Additional Specifications
2.5.1.6	Manage Auxiliary External Inputs/Outputs			O	Yes / No	
		ISO 26048-1§ 8.15.2.1	Configure SRSA	M	Yes	Number of additional SRSA ports to support: _____. This value is exclusive of ports used to monitor cabinet power, cabinet doors, fans, heaters, temperature sensor and humidity sensors.
		ISO 26048-1§ 8.15.2.2	Confirm SRSA port configuration	M	Yes	Not necessary. Delete.
		ISO 26048-1§ 8.15.2.3	Determine SRSA capabilities	M	Yes	
		ISO 26048-1§ 8.15.2.4	Monitor value from SRSA port	M	Yes	
		ISO 26048-1§ 8.15.2.5	Monitor status SRSA port	M	Yes	
		ISO 26048-1§ 8.15.2.6	Monitor status of SRSA type	M	Yes	
		ISO 26048-1§ 8.15.2.7	Set output value of SRSA port	M	Yes	
		ISO 26048-1§ 8.15.2.8	Verify output setting for SRSA port	M	Yes	
		ISO 26048-1§ 8.15.3.1	SRSA port capabilities	M	Yes	
2.5.1.7	Manage Database			M	Yes	
		3.5.1.7.1	Determine Unique Deployment Configuration Identifier	M	Yes	
		3.5.1.7.2	Determine Configuration Identifier Parameter Content	O	Yes / No	
		3.5.1.7.3	Configure Parameters for Creation of an Alternate Device Configuration Identifier	O	Yes / No	
		ISO 26048-1§ 8.6.2.13	Obtain the field device configuration identifier	M	Yes	Effectively the same requirement 3.5.1.7.1.
2.5.1.8	Manage Peer-to-Peer with Other Devices			O	Yes / No	

Protocol Requirements List (PRL)						
User Need ID	User Need	FR ID	Functional Requirement	Conformance	Support	Additional Specifications
		3.5.1.8.1	Configure Peer-to-Peer Identifier Description	M	Yes	Do we want to use notifications? If so, see ISO 26048-1§ 8.10.1.2.1 to 8.10.1.2.18.
		3.5.1.8.2	Configure Peer-to-Peer Connection Target	M	Yes	
		3.5.1.8.3	Configure Peer-to-Peer Connection Trigger Conditions	M	Yes	
		3.5.1.8.4	Configure Peer-to-Peer Connection Action	M	Yes	
		3.5.1.8.5	Determine Maximum Number of Peer-to-Peer Connections	M	Yes	
2.5.1.9	Manage Signal Monitoring Unit Information			O	Yes / No	
		3.5.1.9.1	Enable/Disable Monitoring of the Flash State from the Signal Monitoring Unit	M	Yes	
		3.5.1.9.2	Enable/Disable Monitoring of Channel Voltage from the Signal Monitoring Unit	332:O TS1:O TS2-2:O TS2-1:O ATC:O	Yes / No / NA	
		3.5.1.9.3	Enable/Disable Monitoring of Channel Current from the Signal Monitoring Unit	ATC:O	Yes / No / NA	
2.5.1.10	Manage Interface with External Detectors			O	Yes / No	
			SEE NTCIP 1209			
2.5.1.11	Manage ASC Clock			M	Yes	
		ISO 26048-1§ 8.3.1.2.1	Configure UTC clock	M	Yes	
		ISO 26048-1§ 8.3.1.2.2	Confirm UTC clock configuration	M	Yes	Not necessary. Delete.
		ISO 26048-1§ 8.3.1.2.3	Determine UTC clock capabilities	M	Yes	
		ISO 26048-1§ 8.3.1.2.4	Monitor time discontinuity information	M	Yes	

Protocol Requirements List (PRL)						
User Need ID	User Need	FR ID	Functional Requirement	Conformance	Support	Additional Specifications
		ISO 26048-1§ 8.3.1.2.5	Monitor UTC clock status	M	Yes	
		ISO 26048-1§ 8.3.1.2.6	Monitor UTC time source status	M	Yes	
		ISO 26048-1§ 8.3.1.2.7	Retrieve UTC time	M	Yes	
		ISO 26048-1§ 8.3.1.2.8	Set UTC time	O	Yes / No	
		ISO 26048-1§ 8.3.1.3.1.1	Support for SNMP time configuration	O.4 (1..*)	Yes / No / NA	Recommend Yes.
		ISO 26048-1§ 8.3.1.3.1.2	Support for network time protocol	O.4 (1..*)	Yes / No / NA	Recommend Yes.
		ISO 26048-1§ 8.3.1.3.1.3	Support for radio time broadcast	O.4 (1..*)	Yes / No / NA	
		ISO 26048-1§ 8.3.1.3.1.4	Support for satellite time signal	O.4 (1..*)	Yes / No / NA	
		ISO 26048-1§ 8.3.1.3.2.1	Support line frequency	O.5 (1..*)	Yes / No / NA	
		ISO 26048-1§ 8.3.1.3.2.2	Support crystal	O.5 (1..*)	Yes / No / NA	
		ISO 26048-1§ 8.3.2.2.1	Configure local clock	M	Yes	
		ISO 26048-1§ 8.3.2.2.2	Confirm local clock configuration	M	Yes	
		ISO 26048-1§ 8.3.2.2.3	Retrieve local clock time	M	Yes	
		ISO 26048-1§ 8.3.3.2.1	Configure daylight savings schedule	M	Yes	
		ISO 26048-1§ 8.3.3.2.2	Confirm daylight savings schedule configuration	M	Yes	
		ISO 26048-1§ 8.3.3.2.3	Determine daylight saving time capabilities	M	Yes	
		ISO 26048-1§ 8.3.3.2.4	Monitor daylight savings time adjustment	M	Yes	
		ISO 26048-1§ 8.3.3.2.5	Monitor daylight savings time status	M	Yes	

Protocol Requirements List (PRL)						
User Need ID	User Need	FR ID	Functional Requirement	Conformance	Support	Additional Specifications
		ISO 26048-1§ 8.3.3.3.1	Number of daylight saving entries	M	Yes	Minimum number of daylight savings entries supported (Default: 2) _____
2.5.1.12	Manage External Control Local Application State			O	Yes / No	
		3.5.1.12.1	Enable / Disable ECLA	M	Yes	
		3.5.1.12.2	Configure ECLA Communications Port	M	Yes	
		3.5.1.12.3	Configure ECLA Polling Period	M	Yes	
2.5.2	Manage Signal Operations			M	Yes	
2.5.2.1	Manage Signal Configuration			M	Yes	
2.5.2.1.1	Manage Controller Startup Functions			M	Yes	
		3.5.2.1.1.1.1	Configure Start-Up Flash Mode	O	Yes / No	
		3.5.2.1.1.1.2	Configure Start-Up Flash Time	M	Yes	
		3.5.2.1.1.3	Enable/Disable Automatic Pedestrian Clearance Setting	M	Yes	
		3.5.2.1.1.2.1	Configure Backup Time	M	Yes	
		3.5.2.1.1.2.2 (BackupUD)	Configure User-Defined Backup Time Function	O	Yes / No	The user shall provide a list of all objects to be contained in the Backup timer monitoring. Alternatively, user could require vendor to provide a list.
		3.5.2.1.1.2.3	Determine Maximum Number of Functions Supported for Backup Time	BackupUD:M	Yes / NA	
2.5.2.1.2	Manage Phase Configurations			M	Yes	
		3.5.2.1.2.1.1	Enable/Disable Phase	M	Yes	
		3.5.2.1.2.1.2	Configure Phase Minimum Green Time	M	Yes	
		3.5.2.1.2.1.3	Configure Phase Passage Time	M	Yes	
		3.5.2.1.2.1.4	Configure Phase Maximum Green Times	M	Yes	
		3.5.2.1.2.1.5	Configure Phase Yellow Time	M	Yes	
		3.5.2.1.2.1.6	Configure Red Clearance Time	M	Yes	
		3.5.2.1.2.1.7	Configure Phase Red Revert Time	O	Yes / No	
		3.5.2.1.2.1.8	Configure Unit Red Revert Time	Unit:M	Yes / NA	
		3.5.2.1.2.1.9	Configure Added Initial Time	M	Yes	

Protocol Requirements List (PRL)						
User Need ID	User Need	FR ID	Functional Requirement	Conformance	Support	Additional Specifications
		3.5.2.1.2.1.10	Configure Maximum Initial Time	M	Yes	
		3.5.2.1.2.1.11	Configure Time Before Reduction	M	Yes	
		3.5.2.1.2.1.12	Configure Phase Time to Reduce	M	Yes	
		3.5.2.1.2.1.13	Configure Cars Before Reduction	O	Yes / No	
		3.5.2.1.2.1.14	Configure Phase Reduce By Time	O	Yes / No	
		3.5.2.1.2.1.15	Configure Phase Minimum Gap Time	M	Yes	
		3.5.2.1.2.1.16	Configure Phase Dynamic Maximum Limit	O	Yes / No	
		3.5.2.1.2.1.17	Configure Phase Dynamic Maximum Step	O	Yes / No	
		3.5.2.1.2.1.18	Configure Phase Start-Up State	O	Yes / No	
		3.5.2.1.2.1.19	Configure Automatic Flash Entry Phase	O	Yes / No	
		3.5.2.1.2.1.20	Configure Automatic Flash Exit Phase	O	Yes / No	
		3.5.2.1.2.1.21	Configure Call to Nonactuated 1	O	Yes / No	
		3.5.2.1.2.1.22	Configure Call to Nonactuated 2	O	Yes / No	
		3.5.2.1.2.1.23	Configure Non-Lock Detector Memory	O	Yes / No	
		3.5.2.1.2.1.24	Configure Minimum Vehicle Recall	O	Yes / No	
		3.5.2.1.2.1.25	Configure Maximum Vehicle Recall	O	Yes / No	
		3.5.2.1.2.1.26	Configure Soft Vehicle Recall	O	Yes / No	
		3.5.2.1.2.1.27	Configure Dual Phase Entry	O	Yes / No	
		3.5.2.1.2.1.28	Configure Simultaneous Gap Disable	O	Yes / No	
		3.5.2.1.2.1.29	Configure Guaranteed Passage	O	Yes / No	
		3.5.2.1.2.1.30	Configure Actuated Rest-in-Walk	O	Yes / No	
		3.5.2.1.2.1.31	Configure Conditional Service Enable	O	Yes / No	
		3.5.2.1.2.1.32	Configure Added Initial Calculation	O	Yes / No	
		3.5.2.1.2.1.33	Configure Phase-to-Ring Association	M	Yes	
		3.5.2.1.2.1.34	Configure Phase Concurrency	M	Yes	
		3.5.2.1.2.1.35	Configure Yellow Change Time Before End of Pedestrian Clearance	O	Yes / No	
		3.5.2.1.2.1.36	Enable/Disable Ped-only Phase	O	Yes / No	
		3.5.2.1.2.1.37	Configure Pedestrian Green Time	M	Yes	
		3.5.2.1.2.1.38	Configure Pedestrian Clearance Time	M	Yes	
		3.5.2.1.2.1.39	Configure Pedestrian Phase Walk Recycle Time	M	Yes	

Protocol Requirements List (PRL)						
User Need ID	User Need	FR ID	Functional Requirement	Conformance	Support	Additional Specifications
		3.5.2.1.2.1.40	Configure Pedestrian Phase Don't Walk Revert Time	M	Yes	
		3.5.2.1.2.1.41	Configure Non-Lock Ped Detector Memory	M	Yes	
		3.5.2.1.2.1.42	Configure Pedestrian Recall	M	Yes	
		3.5.2.1.2.1.43	Configure Alternate Pedestrian Clearance Time	O	Yes / No	
		3.5.2.1.2.1.44	Configure Alternate Pedestrian Walk Time	O	Yes / No	
		3.5.2.1.2.1.45	Configure Vehicle Phase Walk Offset Time	O	Yes / No	
		3.5.2.1.2.1.46	Configure Advanced Green Warning	O	Yes / No	
		3.5.2.1.2.1.47	Configure Red Indication Advanced Warning	O	Yes / No	
		3.5.2.1.2.1.48	Configure Flashing Yellow Arrow Associated Vehicle Phase	O	Yes / No	
		3.5.2.1.2.1.49	Configure Flashing Red Arrow Associated Vehicle Phase	O	Yes / No	
		3.5.2.1.2.1.50	Configure Phase Omit	PhsCtrl:M	Yes / NA	
		3.5.2.1.2.1.51	Enable/Disable Phase Omit during Transition	O	Yes / No	
		3.5.2.1.2.1.52	Configure Alternate Minimum Green Time during Transition	O	Yes / No	
		3.5.2.1.2.1.53	Configure Alternate Minimum Walk Time during Transition	O	Yes / No	
		3.5.2.1.2.2.1	Determine Maximum Number of Phases	M	Yes	The ASC shall support at least ___ phases.
		3.5.2.1.2.2.2	Retrieve Current Phase Configuration	M	Yes	
2.5.2.1.3 (Coord)	Manage Coordination Configurations			O	Yes / No	
	3.5.2.1.3.1	Configure Operational Mode for Coordination	M	Yes	The ASC shall support the following values: ___ automatic ___ pattern ___ manual free ___ manual flash	

Protocol Requirements List (PRL)						
User Need ID	User Need	FR ID	Functional Requirement	Conformance	Support	Additional Specifications
		3.5.2.1.3.2	Configure Correction Mode for Coordination	M	Yes	The ASC shall support the following values: <input type="checkbox"/> dwell <input type="checkbox"/> shortway <input type="checkbox"/> add only <input type="checkbox"/> subtract only
		3.5.2.1.3.3	Configure Maximum Mode for Coordination Requirements	M	Yes	The ASC shall support the following values: <input type="checkbox"/> maxInhibit <input type="checkbox"/> maximum1 <input type="checkbox"/> maximum2 <input type="checkbox"/> maximum3
		3.5.2.1.3.4.1	Configure Unit-level Force Mode for Coordination - Floating	O.6 (1..*)	Yes / No	
		3.5.2.1.3.4.2	Configure Unit-level Force Mode for Coordination - Fixed	O.6 (1..*)	Yes / No	
		3.5.2.1.3.4.3	Configure Phase-level Force Mode for Coordination - Floating	O	Yes / No	
		3.5.2.1.3.4.4	Configure Phase-level Force Mode for Coordination - Fixed	O	Yes / No	
		3.5.2.1.3.5.1	Configure Unit Coordination Point	M	Yes	
		3.5.2.1.3.5.2	Configure Pattern Coordination Point	M	Yes	
2.5.2.1.4	Manage Timing Patterns			Coord:M	Yes / NA	
		3.5.2.1.4.1.1	Configure Pattern Cycle Time	M	Yes	
		3.5.2.1.4.1.2	Configure Pattern Offset Time	M	Yes	
		3.5.2.1.4.1.3	Configure Pattern Split Association	M	Yes	
		3.5.2.1.4.1.4	Configure Pattern Sequence Association	M	Yes	
		3.5.2.1.4.1.5	Configure Pattern Maximum Mode	O	Yes / No	
		3.5.2.1.4.2.1	Determine Maximum Number of Phase-based Timing Pattern	M	Yes	The ASC shall support at least <input type="checkbox"/> timing patterns.
		3.5.2.1.4.2.2	Determine Timing Pattern Type	M	Yes	The ASC shall support one of the following types of signal patterns (Select one only): <input type="checkbox"/> Each pattern is unique <input type="checkbox"/> Each pattern consists of a plan with 3 different offsets <input type="checkbox"/> Each pattern consists of a plan with 5 different offsets

Protocol Requirements List (PRL)						
User Need ID	User Need	FR ID	Functional Requirement	Conformance	Support	Additional Specifications
2.5.2.1.5	Manage Splits Configurations			O	Yes / No	
		3.5.2.1.5.1.1	Configure Phase Split Time	M	Yes	
		3.5.2.1.5.1.2	Configure Phase Split Mode	M	Yes	
		3.5.2.1.5.1.3	Configure Split Coordination Phase	M	Yes	
		3.5.2.1.5.1.4	Configure Pre-timed Split	O	Yes / No	
		3.5.2.1.5.2	Determine Maximum Number of Phase Splits	M	Yes	The ASC shall support at least ___ splits
2.5.2.1.6 (Ring)	Manage Ring Configurations			O	Yes / No	
		3.5.2.1.6.1.1	Configure Sequence Data	M	Yes	
		3.5.2.1.6.1.2	Determine Maximum Number of Rings	M	Yes	The ASC shall support at least ___ rings
		3.5.2.1.6.1.3	Determine Maximum Number of Sequences	M	Yes	The ASC shall support at least ___ sequences
2.5.2.1.7 (Channel)	Manage Channel Configurations			O	Yes / No	
		3.5.2.1.7.1.1	Configure Channel Control Source	M	Yes	
		3.5.2.1.7.1.2	Configure Channel Control Type	M	Yes	
		3.5.2.1.7.1.3	Configure Channel Automatic Flash	M	Yes	
		3.5.2.1.7.1.4.1	Enable/Disable Channel Dim - Green	Dimming:O	Yes / No / NA	
		3.5.2.1.7.1.4.2	Enable/Disable Channel Dim - Yellow	Dimming:O	Yes / No / NA	
		3.5.2.1.7.1.4.3	Enable/Disable Channel Dim - Red	Dimming:O	Yes / No / NA	
		3.5.2.1.7.1.4.4	Enable/Disable Channel Dim - Alternate Half Hertz	Dimming:O	Yes / No / NA	
		3.5.2.1.7.2.1	Determine Maximum Number of Channels	M	Yes	The ASC shall support at least ___ channels (See appropriate hardware specification such as NEMA TS 2 to determine maximum number of supported channels)
		3.5.2.1.7.2.2	Retrieve Channel Definitions	M	Yes	
2.5.2.1.8 (Overlap)	Manage Overlap Configurations			O	Yes / No	

Protocol Requirements List (PRL)						
User Need ID	User Need	FR ID	Functional Requirement	Conformance	Support	Additional Specifications
		3.5.2.1.8.1.1.1	Configure Overlap Type - Vehicle Normal	O.7 (1..*)	Yes / No	
		3.5.2.1.8.1.1.2	Configure Overlap Type - Vehicle Minus Green and Yellow	O.7 (1..*)	Yes / No	
		3.5.2.1.8.1.1.3	Configure Overlap Type - Pedestrian Normal	O.7 (1..*)	Yes / No	
		3.5.2.1.8.1.1.4	Configure Overlap Type - Flashing Yellow Arrow - 3 Section Head	O.7 (1..*)	Yes / No	
		3.5.2.1.8.1.1.5	Configure Overlap Type - Flashing Yellow Arrow - 4 Section Head	O.7 (1..*)	Yes / No	
		3.5.2.1.8.1.1.6	Configure Overlap Type - Flashing Red Arrow - 3 Section Head	O.7 (1..*)	Yes / No	
		3.5.2.1.8.1.1.7	Configure Overlap Type - Flashing Red Arrow - 4 Section Head	O.7 (1..*)	Yes / No	
		3.5.2.1.8.1.1.8	Configure Overlap Type - 2 Section Transit Specific Signal Head	O.7 (1..*)	Yes / No	
		3.5.2.1.8.1.1.9	Configure Overlap Type – Minus Green Yellow Alternate	O.7(1..*)	Yes / No	
		3.5.2.1.8.1.2	Configure Overlap Included Phases	M	Yes	
		3.5.2.1.8.1.3	Configure Overlap Modifier Phases	O	Yes / No	
		3.5.2.1.8.1.4	Configure Pedestrian Modifier Phases	O	Yes / No	
		3.5.2.1.8.1.5	Configure Overlap Trailing Green	M	Yes	
		3.5.2.1.8.1.6	Configure Overlap Trailing Yellow	M	Yes	
		3.5.2.1.8.1.7	Configure Overlap Trailing Red Clearance	M	Yes	
		3.5.2.1.8.1.8	Configure Overlap Walk	O	Yes / No	
		3.5.2.1.8.1.9	Configure Overlap Pedestrian Clearance	O	Yes / No	
		3.5.2.1.8.2.1	Determine Maximum Number of Overlaps	M	Yes	The ASC shall support at least _____ overlaps
		3.5.2.1.8.2.2	Retrieve Overlap Definitions	M	Yes	
		2.5.2.1.9 (Preempt)	Manage Preempt Configurations			O
		3.5.2.1.9.1.1	Enable/Disable Preempt Inputs	O	Yes / No	

Protocol Requirements List (PRL)						
User Need ID	User Need	FR ID	Functional Requirement	Conformance	Support	Additional Specifications
		3.5.2.1.9.1.2	Configure Preempt Control - Non-Locking Memory	O	Yes / No	
		3.5.2.1.9.1.3	Configure Preempt Control - Override Automatic Flash	O	Yes / No	
		3.5.2.1.9.1.4	Configure Preempt Control - Preempt Override	O	Yes / No	
		3.5.2.1.9.1.5	Configure Preempt Control - Flash Dwell	O	Yes / No	
		3.5.2.1.9.1.6	Configure Preempt Link	M	Yes	
		3.5.2.1.9.1.7	Configure Preempt Delay	M	Yes	
		3.5.2.1.9.1.8	Configure Preempt Minimum Duration	M	Yes	
		3.5.2.1.9.1.9.1	Configure Preempt Enter Minimum Green Time	O	Yes / No	
		3.5.2.1.9.1.9.2	Configure Preempt Enter Minimum Walk Time	O	Yes / No	
		3.5.2.1.9.1.9.3	Configure Preempt Enter Pedestrian Clearance Time	O	Yes / No	
		3.5.2.1.9.1.9.4	Configure Preempt Enter Yellow Time	O	Yes / No	
		3.5.2.1.9.1.9.5	Configure Preempt Enter Red Clearance Time	O	Yes / No	
		3.5.2.1.9.1.10.1	Configure Preempt Track Clearance Yellow Change Time	O	Yes / No	
		3.5.2.1.9.1.10.2	Configure Preempt Track Clearance Red Clearance Time	O	Yes / No	
		3.5.2.1.9.1.10.3	Configure Preempt Track Clearance Interval Time	M	Yes	
		3.5.2.1.9.1.10.4	Configure Preempt Track Clearance Phases	M	Yes	
		3.5.2.1.9.1.10.5	Configure Preempt Track Clearance Overlaps	O	Yes / No	
		3.5.2.1.9.1.11.1	Configure Preempt Minimum Green Dwell Time	M	Yes	
		3.5.2.1.9.1.11.2	Configure Preempt Dwell Phases	M	Yes	
		3.5.2.1.9.1.11.3	Configure Preempt Dwell Pedestrian Movements	O	Yes / No	

Protocol Requirements List (PRL)						
User Need ID	User Need	FR ID	Functional Requirement	Conformance	Support	Additional Specifications
		3.5.2.1.9.1.11.4	Configure Preempt Dwell Overlaps	O	Yes / No	
		3.5.2.1.9.1.11.5	Configure Preempt Cycling Phases	O	Yes / No	
		3.5.2.1.9.1.11.6	Configure Preempt Cycling Pedestrian Movements	O	Yes / No	
		3.5.2.1.9.1.11.7	Configure Preempt Cycling Phases Sequence	O	Yes / No	
		3.5.2.1.9.1.11.8	Configure Preempt Cycling Overlaps	O	Yes	
		3.5.2.1.9.1.12.1 (preemptExit)	Configure Preempt Exit Phases	O	Yes / No	
		3.5.2.1.9.1.12.2	Configure Preempt Exit Overlaps	preemptExit:O	Yes / No	
		3.5.2.1.9.1.12.3	Configure Preempt Exit Phase Strategy	O	Yes / No	
		3.5.2.1.9.1.12.4	Configure Preempt Exit Priority Levels	C	Yes / No	Mandatory for Conformance if 'Exit to Queue Delay Recovery' is supported as a Preempt Exit Phase (See 3.5.2.1.9.1.12.1)
		3.5.2.1.9.1.13.1	Configure Preempt Maximum Presence Time	M	Yes	
		3.5.2.1.9.1.13.2	Configure Preempt Maximum Presence Exceeded	M	Yes	
		3.5.2.1.9.1.14	Configure Preempt Gate Description	O	Yes / No	
		3.5.2.1.9.2	Determine Maximum Number of Preempts	M	Yes	The ASC shall support at least _____ preempts
2.5.2.1.10 (Scheduler)	Manage Timing Pattern Scheduler			O	Yes / No	
		3.5.2.1.10.1	Configure Timebase Pattern Synchronization Time	M	Yes	
		ISO 26048-1§ 8.7.2.1	Change status of day plan scheduler	M	Yes	
		ISO 26048-1§ 8.7.2.2	Change status of day plan schedule rule	M	Yes	
		ISO 26048-1§ 8.7.2.3	Change status of day plan	M	Yes	
		ISO 26048-1§ 8.7.2.4	Change status of day plan trigger	M	Yes	

Protocol Requirements List (PRL)						
User Need ID	User Need	FR ID	Functional Requirement	Conformance	Support	Additional Specifications
		ISO 26048-1§ 8.7.2.5	Configure day plan selection rule	M	Yes	
		ISO 26048-1§ 8.7.2.6	Configure day plan	M	Yes	
		ISO 26048-1§ 8.7.2.7	Configure a day plan trigger	M	Yes	
		ISO 26048-1§ 8.7.2.8	Confirm day plan selection rule configuration	M	Yes	Not necessary. Delete.
		ISO 26048-1§ 8.7.2.9	Confirm day plan configuration	M	Yes	Not necessary. Delete.
		ISO 26048-1§ 8.7.2.10	Confirm day plan trigger configuration	M	Yes	Not necessary. Delete.
		ISO 26048-1§ 8.7.2.11	Delete a day plan schedule rule	M	Yes	
		ISO 26048-1§ 8.7.2.12	Delete a day plan	M	Yes	
		ISO 26048-1§ 8.7.2.13	Delete a day plan trigger	M	Yes	
		ISO 26048-1§ 8.7.2.14	Monitor day plan schedule statistics	M	Yes	
		ISO 26048-1§ 8.7.2.15	Monitor day plan scheduler status	M	Yes	
		2.5.2.1.11	Manage Action Scheduler			O
		3.5.2.1.11.1	Configure Action Scheduler Synchronization Time	M	Yes	
		3.5.2.1.11.2	Configure Timebased Action - Pattern	M	Yes	
		ISO 26048-1§ 8.7.2.1	Change status of day plan scheduler	M	Yes	
		ISO 26048-1§ 8.7.2.2	Change status of day plan schedule rule	M	Yes	
		ISO 26048-1§ 8.7.2.3	Change status of day plan	M	Yes	
		ISO 26048-1§ 8.7.2.4	Change status of day plan trigger	M	Yes	
		ISO 26048-1§ 8.7.2.5	Configure day plan selection rule	M	Yes	

Protocol Requirements List (PRL)						
User Need ID	User Need	FR ID	Functional Requirement	Conformance	Support	Additional Specifications
		ISO 26048-1§ 8.7.2.6	Configure day plan	M	Yes	
		ISO 26048-1§ 8.7.2.7	Configure a day plan trigger	M	Yes	
		ISO 26048-1§ 8.7.2.8	Confirm day plan selection rule configuration	M	Yes	Not necessary. Delete.
		ISO 26048-1§ 8.7.2.9	Confirm day plan configuration	M	Yes	Not necessary. Delete.
		ISO 26048-1§ 8.7.2.10	Confirm day plan trigger configuration	M	Yes	Not necessary. Delete.
		ISO 26048-1§ 8.7.2.11	Delete a day plan schedule rule	M	Yes	
		ISO 26048-1§ 8.7.2.12	Delete a day plan	M	Yes	
		ISO 26048-1§ 8.7.2.13	Delete a day plan trigger	M	Yes	
		ISO 26048-1§ 8.7.2.14	Monitor day plan schedule statistics	M	Yes	
		ISO 26048-1§ 8.7.2.15	Monitor day plan scheduler status	M	Yes	
		2.5.2.1.12	Manage I/O Mapping			O
		3.5.2.1.12.1.1	Set Active I/O Map	M	Yes	
		3.5.2.1.12.1.2.1	Configure I/O Map Description	M	Yes	
		3.5.2.1.12.1.2.2.1	Configure I/O Map Input Device	M	Yes	
		3.5.2.1.12.1.2.2.2	Configure I/O Map Input Device Pin	M	Yes	
		3.5.2.1.12.1.2.2.3	Configure I/O Map Input Function	M	Yes	
		3.5.2.1.12.1.2.3.1	Configure I/O Map Output Device	M	Yes	
		3.5.2.1.12.1.2.3.2	Configure I/O Map Output Device Pin	M	Yes	
		3.5.2.1.12.1.2.3.3	Configure I/O Map Output Function	M	Yes	
		3.5.2.1.12.2.1	Retrieve Maximum Number of I/O Maps	M	Yes	
		3.5.2.1.12.2.2	Retrieve Maximum Number of I/O Map Inputs	M	Yes	
		3.5.2.1.12.2.3	Retrieve Maximum Number of I/O Map Outputs	M	Yes	

Protocol Requirements List (PRL)						
User Need ID	User Need	FR ID	Functional Requirement	Conformance	Support	Additional Specifications
		3.5.2.1.12.2.4	Retrieve I/O Mapping Activate Conditions	M	Yes	The following conditions shall be satisfied before a new I/O map can be activated: <input type="checkbox"/> Cabinet Door Open <input type="checkbox"/> in any flash state <input type="checkbox"/> programmed all red flash in CVM flash <input type="checkbox"/> ASC restart
		3.5.2.1.12.2.5	Retrieve I/O Mapping Input Functions	M	Yes	
		3.5.2.1.12.2.6	Retrieve I/O Mapping Output Functions	M	Yes	
		3.5.2.1.12.2.7	Retrieve I/O Map Input Device Pin Status	M	Yes	
		3.5.2.1.12.2.8	Retrieve I/O Map Output Device Pin Status	M	Yes	
		3.5.2.1.12.2.9.1	Enumerate I/O Map - FIO Inputs	332:M	Yes / NA	
		3.5.2.1.12.2.9.2	Enumerate I/O Map - FIO Outputs	332:M	Yes / NA	
		3.5.2.1.12.2.9.3	Enumerate I/O Map - TS1 Inputs	TS1, TS2-2:M	Yes / NA	
		3.5.2.1.12.2.9.4	Enumerate I/O Map - TS1 Outputs	TS1, TS2-2:M	Yes / NA	
		3.5.2.1.12.2.9.5	Enumerate I/O Map - TS2 BIU Inputs	TS2-1:M	Yes / NA	
		3.5.2.1.12.2.9.6	Enumerate I/O Map - TS2 BIU Outputs	TS2-1:M	Yes / NA	
		3.5.2.1.12.2.9.7	Enumerate I/O Map - ATC Cabinet SIU Inputs	ATC:M	Yes / NA	
		3.5.2.1.12.2.9.8	Enumerate I/O Map - ATC Cabinet SIU Outputs	ATC:M	Yes / NA	
		3.5.2.1.12.2.9.9	Enumerate I/O Map - Auxiliary Device Inputs	O	Yes / No	
		3.5.2.1.12.2.9.10	Enumerate I/O Map - Auxiliary Device Outputs	O	Yes / No	
2.5.2.1.13 (Intra)	Manage Intra-Cabinet Communications Configuration			O	Yes / No	
		3.5.2.1.13.1	Determine Serial Bus 1 Device Present	ATC:M	Yes / NA	The ASC shall support at least <input type="checkbox"/> Serial Bus 1 Addresses (between 1 and 255).

Protocol Requirements List (PRL)						
User Need ID	User Need	FR ID	Functional Requirement	Conformance	Support	Additional Specifications
		3.5.2.1.13.2.1	Determine TS2 Port 1 Device Present	TS2-2:M	Yes / NA	The ASC shall support at least ____ TS2 Port1 Addresses (between 1 and 255).
		3.5.2.1.13.2.2	Determine TS2 Port 1 Frame 40 Enable	TS2-2:M	Yes / NA	
2.5.2.1.14	Manage Pedestrian Support			O	Yes / No	
		3.5.2.1.14.1.1	Configure APS Push Button Minimum Press Time	M	Yes	
		3.5.2.1.14.1.2	Configure APS Push Button to Phase Association	M	Yes	
		3.5.2.1.14.1.3	Configure APS Extra Crossing Time	M	Yes	
		3.5.2.1.14.2	Determine Maximum Number of Pedestrian Buttons	M	Yes	The ASC shall support at least ____ Pedestrian Push Button inputs (between 1 and 16).
2.5.2.2	Monitor Signal Operations Status					
2.5.2.2.1	Determine Controller Health			M	Yes	
		ISO 26048-1§ 8.6.2.9	Monitor when the SNMP capabilities last changed	M	Yes	
		ISO 26048-1§ 8.6.2.10	Monitor controller operational status	M	Yes	
		ISO 26048-1§ 8.6.2.11	Monitor controller up time	M	Yes	
		ISO 26048-1§ 8.6.2.12	Monitor watchdog failure count	M	Yes	
		3.5.2.2.1.1	Monitor Alarm State	M	Yes	The ASC shall support at least ____ Alarm Groups (between 1 and 255).
		3.5.2.2.1.2	Monitor Preempt Active	Preempt:M	Yes / NA	
		3.5.2.2.1.3	Monitor Terminal and Facilities Flash	M	Yes	
		3.5.2.2.1.4	Monitor Local Cycle Zero Alarm	M	Yes	
		3.5.2.2.1.5	Monitor Local Override	M	Yes	
		3.5.2.2.1.6	Monitor Coordination Alarm	Coord:M	Yes / NA	
3.5.2.2.1.7	Monitor Detector Fault	Detector:M	Yes / NA			
3.5.2.2.1.8	Monitor Non-Critical Alarm	M	Yes			
3.5.2.2.1.9	Monitor Stop Time Input Alarm	M	Yes			

Protocol Requirements List (PRL)						
User Need ID	User Need	FR ID	Functional Requirement	Conformance	Support	Additional Specifications
		3.5.2.2.1.10	Monitor Cycle Fault Alarm	M	Yes	
		3.5.2.2.1.11	Monitor Coordination Fault	Coord:M	Yes / NA	
		3.5.2.2.1.12	Monitor Coordination Fail Alarm	Coord:M	Yes / NA	
		3.5.2.2.1.13	Monitor Cycle Fail Alarm	M	Yes	
		3.5.2.2.1.14	Monitor SMU Flash Alarm	M	Yes	
		3.5.2.2.1.15	Monitor Local Flash Alarm	M	Yes	
		3.5.2.2.1.16	Monitor Local Free Alarm	M	Yes	
		3.5.2.2.1.17	Monitor Coordination Active Alarm	Coord:M	Yes / NA	
		3.5.2.2.1.18	Monitor Power Restart Alarm	Power:M	Yes / NA	
		3.5.2.2.1.19	Monitor Low Battery Alarm	Power:O	Yes / No / NA	
		3.5.2.2.1.20	Monitor Response Fault Alarm	M	Yes	
		3.5.2.2.1.21	Monitor External Start	M	Yes	
		3.5.2.2.1.22	Monitor Stop Time Alarm	M	Yes	
		3.5.2.2.1.23	Monitor Offset Transitioning Alarm	M	Yes	
		3.5.2.2.1.24	Monitor Stall Condition	M	Yes	The vendor shall list the ASC processes or services where a watchdog timer is maintained and is considered critical to the safe operation of the ASC.
		3.5.2.2.1.25	Monitor Memory Fault	M	Yes	
		3.5.2.2.1.26	Monitor Process Failure	M	Yes	
		3.5.2.2.1.27	Monitor Communications Timeout	M	Yes	
		3.5.2.2.1.28	Monitor Power Problems	Power:M	Yes / NA	
		3.5.2.2.1.29	Monitor UPS Errors	UPS:O	Yes / No / NA	
		3.5.2.2.1.30	Monitor Scheduler Errors	Scheduler:M	Yes / NA	
		3.5.2.2.1.31	Monitor Signal Monitor Communications Error	O	Yes / No	
		3.5.2.2.1.32	Monitor Signal Monitor Unit Presence	O	Yes / No	
		3.5.2.2.1.33	Monitor USB Memory Device	O	Yes / No	
		3.5.2.2.1.34	Monitor ASC Cabinet Temperature Alarm	M	Yes / NA	
		3.5.2.2.1.35	Monitor ASC Cabinet Humidity Alarm	M	Yes / NA	
		3.5.2.2.1.36	Monitor Clock Failure	M	Yes	
		3.5.2.2.1.37	Monitor Preempt Maximum Presence Alarm	Preempt:O	Yes / No / NA	

Protocol Requirements List (PRL)						
User Need ID	User Need	FR ID	Functional Requirement	Conformance	Support	Additional Specifications
		3.5.2.2.1.38	Monitor RSU Watchdog Timer	CV:M	Yes / NA	
		3.5.2.2.1.39	Monitor CV Certificate Faults	CV:O	Yes / No / NA	
2.5.2.2.2	Determine Mode of Operation					
2.5.2.2.2.1 (Unit)	Monitor Unit-wide General Operations			O	Yes / No	
		3.5.2.2.2.1.1	Monitor Unit Control Status	M	Yes	
		3.5.2.2.2.1.2	Monitor Interconnect	O	Yes / No	
		3.5.2.2.2.1.3 (Dimming)	Monitor Dimming Enabled	O	Yes / No	
2.5.2.2.2.2	Monitor Flashing			Unit:M	Yes / NA	
		3.5.2.2.2.2	Monitor Unit Flash Status	M	Yes	
2.5.2.2.2.3	Monitor Current Timing Pattern			Coord:M	Yes / NA	
		3.5.2.2.2.3.1	Monitor Current Pattern Status	M	Yes	
		3.5.2.2.2.3.2	Monitor Local Free Status	M	Yes	
		3.5.2.2.2.3.3	Monitor Current Mode of Operation	M	Yes	
		3.5.2.2.2.3.4	Monitor Programmed Pattern	M	Yes	
		3.5.2.2.2.3.5	Monitor Pattern Source	M	Yes	
2.5.2.2.2.4	Monitor Current Cycle			Coord:M	Yes / NA	
		3.5.2.2.2.4.1	Monitor Coordination Cycle Status	M	Yes	
		3.5.2.2.2.4.2	Monitor Coordination Synchronization Status	M	Yes	
		3.5.2.2.2.4.3	Monitor Current Split	M	Yes	
		3.5.2.2.2.4.4	Monitor Phase End Duration	M	Yes	
		3.5.2.2.2.4.5	Monitor Current Offset	M	Yes	
2.5.2.2.3	Monitor Signal Indication			M	Yes	
		3.5.2.2.3.1	Monitor Active Red Phases	M	Yes	
		3.5.2.2.3.2	Monitor Active Yellow Phases	M	Yes	
		3.5.2.2.3.3	Monitor Active Green Phases	M	Yes	
		3.5.2.2.3.4	Monitor Active Don't Walk Phases	M	Yes	
		3.5.2.2.3.5	Monitor Active Pedestrian Clearance Phases	M	Yes	
		3.5.2.2.3.6	Monitor Active Walk Phases	M	Yes	
		3.5.2.2.3.7	Monitor Active Flashing Yellow Arrow Phases	O	Yes / No	

Protocol Requirements List (PRL)						
User Need ID	User Need	FR ID	Functional Requirement	Conformance	Support	Additional Specifications
		3.5.2.2.3.8	Monitor Active Flashing Red Arrow Phases	O	Yes / No	
2.5.2.2.4	Monitor Phase Status			M	Yes	
		3.5.2.2.4.1	Monitor Active Phases	M	Yes	
		3.5.2.2.4.2	Monitor Next Phases	M	Yes	
		3.5.2.2.4.3	Monitor Vehicle Calls	M	Yes	
		3.5.2.2.4.4	Monitor Pedestrian Calls	M	Yes	
2.5.2.2.5	Monitor Ring Status			Ring:M	Yes / NA	
		3.5.2.2.5.1	Monitor Ring Status	M	Yes	
		3.5.2.2.5.2	Monitor Ring Termination Cause	M	Yes	
2.5.2.2.6	Monitor Channel Status			Channel:M	Yes / NA	
		3.5.2.2.6.1	Monitor Active Red Channels	M	Yes	
		3.5.2.2.6.2	Monitor Active Yellow Channels	M	Yes	
		3.5.2.2.6.3	Monitor Active Green Channels	M	Yes	
2.5.2.2.7	Monitor Overlap Status			Overlap:M	Yes / NA	
		3.5.2.2.7.1	Monitor Active Red Overlaps	M	Yes	
		3.5.2.2.7.2	Monitor Active Yellow Overlaps	M	Yes	
		3.5.2.2.7.3	Monitor Active Green Overlaps	M	Yes	
		3.5.2.2.7.4	Monitor Active Flashing Yellow Arrow Overlaps	O	Yes / No	
		3.5.2.2.7.5	Monitor Active Flashing Red Arrow Overlaps	O	Yes / No	
2.5.2.2.8	Monitor Preempt Status			Preempt:M	Yes / NA	
		3.5.2.2.8.1	Monitor Currently Active Preempt	M	Yes	
		3.5.2.2.8.2	Monitor Current Preempt Inputs	M	Yes	
		3.5.2.2.8.3	Monitor Current Preempt State	M	Yes	
		3.5.2.2.8.4	Monitor Current Gate Status	O	Yes / No	
2.5.2.2.9 (SpecialFunc)	Monitor Special Function Outputs			O	Yes / No	
		3.5.2.2.9.1	Determine Maximum Number of Special Functions	M	Yes	The ASC shall support at least ___ Special Functions (between 1 and 255).
		3.5.2.2.9.2	Monitor Special Function Status	M	Yes	

Protocol Requirements List (PRL)						
User Need ID	User Need	FR ID	Functional Requirement	Conformance	Support	Additional Specifications
		3.5.2.2.9.3	Monitor Special Function Control Source	O	Yes / No	
2.5.2.2.10	Monitor Timebase Action Status			Scheduler:M	Yes / NA	
		3.5.2.2.10.1	Monitor Timebase Action Status	M	Yes	
		3.5.2.2.10.2	Monitor Timebase Timing Pattern Status	M	Yes	
2.5.2.2.11	Monitor Intra-Cabinet Communications Configuration			O	Yes / No	
		3.5.2.2.11.1	Monitor TS2 Port 1 Status	TS2-2:M	Yes / NA	
		3.5.2.2.11.2	Monitor TS2 Port 1 Fault Frame	TS2-2:M	Yes / NA	
		3.5.2.2.11.3	Monitor Serial Bus 1 Status	ATC:M	Yes / NA	
2.5.2.2.12	Monitor Peer-to-Peer State			O	Yes / No	
		3.5.2.2.12.1	Monitor Peer-to-Peer Trigger Count	M	Yes	
		3.5.2.2.12.2	Monitor Peer-to-Peer Trigger Failure Count	M	Yes	
		3.5.2.2.12.3	Monitor Peer-to-Peer Action Failure Count	M	Yes	
2.5.2.2.13	Monitor Signal Monitoring Unit			O	Yes / No	
		3.5.2.2.13.1	Monitor Signal Monitoring Cabinet Flash State	M	Yes	
		3.5.2.2.13.2	Monitor Signal Monitoring Unit Channel Voltage	M	Yes	
		3.5.2.2.13.3	Monitor Signal Monitoring Unit Channel Current	M	Yes	
		3.5.2.2.13.4	Retrieve Programmed Conflicts from the Signal Monitoring Unit	M	Yes	
2.5.2.3	Control Signal Operations			M	Yes	
2.5.2.3.1	Control ASC-wide General Operations			M	Yes	
		3.5.2.3.1.1	Control External Minimum Recall	M	Yes	
		3.5.2.3.1.2	Control Call to Nonactuated 1	M	Yes	
		3.5.2.3.1.3	Control Call to Nonactuated 2	O	Yes / No	
		3.5.2.3.1.4	Control Walk Rest Modifier	M	Yes	
		3.5.2.3.1.5	Control Interconnect	O	Yes / No	
		3.5.2.3.1.6	Control Dimming Enabled	Dimming:M	Yes / NA	
		3.5.2.3.1.7	Disable Remote Commands	O	Yes / No	
		3.5.2.3.1.8	Acknowledge Local Cycle Zero Alarm	M	Yes	

Protocol Requirements List (PRL)						
User Need ID	User Need	FR ID	Functional Requirement	Conformance	Support	Additional Specifications
2.5.2.3.2	Command Timing Pattern			Coord:M	Yes / NA	
		3.5.2.3.2.1	Command System Timing Pattern	M	Yes	
		3.5.2.3.2.2	Command System Timing Pattern System Reference Point	M	Yes	
2.5.2.3.3 (PhsCtrl)	Phase Requests			O	Yes / No	
		3.5.2.3.3.1	Control Phase Omits	M	Yes	
		3.5.2.3.3.2	Control Pedestrian Phase Omits	M	Yes	
		3.5.2.3.3.3	Control Phase Holds	M	Yes	
		3.5.2.3.3.4	Control Phase Force Offs	O	Yes / No	
		3.5.2.3.3.5	Control Phase Vehicle Calls	M	Yes	
		3.5.2.3.3.6	Control Phase Pedestrian Calls	M	Yes	
2.5.2.3.4	Activate Preempt			Preempt:O	Yes / No	
		3.5.2.3.4.1	Command Preempt Remote Activation	M	Yes	
2.5.2.3.5	Control Ring Operations			Ring:O	Yes / No / NA	
		3.5.2.3.5.1	Control Ring Stop Time	M	Yes	
		3.5.2.3.5.2	Control Ring Force Offs	M	Yes	
		3.5.2.3.5.3	Control Ring Maximum Settings	M	Yes	
		3.5.2.3.5.4	Control Ring Pedestrian Recycle Settings	M	Yes	
		3.5.2.3.5.5	Control Ring Red Rest Settings	M	Yes	
		3.5.2.3.5.6	Control Ring Red Clearance Omit Settings	M	Yes	
2.5.2.3.6	Activate Special Function Output			SpecialFunc:O	Yes / No / NA	
		3.5.2.3.6.1	Activate Special Function	M	Yes	
		3.5.2.3.6.2	Release Special Function Control	M	Yes	
2.5.2.3.7	Control Frame 40			TS1:O TS2-2:O TS2-1:O	Yes / No / NA	
		3.5.2.3.7.1	Control TS2 Port 1 Frame 40 Messages	M	Yes	
2.5.2.3.8	Activate Action Plan			O	Yes / No	
		3.5.2.3.8	Activate Action Plan	M	Yes	
2.5.2.3.9	Remote Manual Control			O	Yes / No	

Protocol Requirements List (PRL)						
User Need ID	User Need	FR ID	Functional Requirement	Conformance	Support	Additional Specifications
		3.5.2.3.9.1	Enable Remote Manual Control	M	Yes	
		3.5.2.3.9.2	Remote Manual Control Advance Command	M	Yes	
		3.5.2.3.9.3	Configure Manual Control Timeout	M	Yes	
2.5.3	Manage Detectors					
2.5.3.1 (Detector)	Manage Detector Configuration			M	Yes	
		3.5.3.1.1.1	Configure Vehicle Travel Mode	O	Yes / No	
		3.5.3.1.1.2	Configure Vehicle Detector Yellow Lock Call Enabled	O	Yes / No	
		3.5.3.1.1.3	Configure Vehicle Detector Red Lock Call Enabled	O	Yes / No	
		3.5.3.1.1.4	Configure Vehicle Detector Passage Enabled	O	Yes / No	
		3.5.3.1.1.5	Configure Vehicle Detector Added Initial Time Enabled	O	Yes / No	
		3.5.3.1.1.6	Configure Vehicle Detector Queue Enabled	O	Yes / No	
		3.5.3.1.1.7	Configure Vehicle Detector Call Enabled	M	Yes	
		3.5.3.1.1.8	Configure Vehicle Detector Call Phase	M	Yes	
		3.5.3.1.1.9	Configure Vehicle Detector Switch Phase	M	Yes	
		3.5.3.1.1.10	Configure Vehicle Detector Delay Time	M	Yes	
		3.5.3.1.1.11	Configure Vehicle Detector Extend Time	M	Yes	
		3.5.3.1.1.12	Configure Vehicle Detector Queue Limit Time	O	Yes / No	
		3.5.3.1.1.13	Configure Vehicle Detector No Activity Fault Time	M	Yes	
		3.5.3.1.1.14	Configure Vehicle Detector Maximum Presence Fault Time	M	Yes	
		3.5.3.1.1.15	Configure Vehicle Detector Erratic Counts	M	Yes	

Protocol Requirements List (PRL)						
User Need ID	User Need	FR ID	Functional Requirement	Conformance	Support	Additional Specifications
		3.5.3.1.1.16	Configure Vehicle Detector Fail Time	O	Yes / No	
		3.5.3.1.2.1	Configure Pedestrian Detector Call Phase	M	Yes	
		3.5.3.1.2.2	Configure Pedestrian Detector No Activity Fault Time	M	Yes	
		3.5.3.1.2.3	Configure Pedestrian Detector Maximum Presence Fault Time	M	Yes	
		3.5.3.1.2.4	Configure Pedestrian Detector Erratic Counts	M	Yes	
		3.5.3.1.2.5	Configure Pedestrian Detector Non-Lock Calls	O	Yes / No	
		3.5.3.1.2.6	Configure Pedestrian Detector Alternate Pedestrian Timing	O	Yes / No	
		3.5.3.1.2.7	Configure Pedestrian Detector Type	O	Yes / No	
		3.5.3.1.3.1.1	Determine Maximum Number of Vehicle Detectors	O	Yes / No	The ASC shall support at least ____ vehicle detectors (between 1 and 255).
		3.5.3.1.3.1.2	Retrieve Vehicle Detector Configurations	O	Yes / No	
		3.5.3.1.3.2.1	Determine Maximum Number of Pedestrian Detectors	O	Yes / No	The ASC shall support at least ____ pedestrian detectors (between 1 and 255).
		3.5.3.1.3.2.2	Retrieve Pedestrian Detector Configurations	O	Yes / No	
		2.5.3.2	Monitor Detector Status			O
		3.5.3.2.1	Determine Detector Data Active Detectors	M	Yes	
		3.5.3.2.2	Monitor Active Vehicle Detector Status	M	Yes	
		3.5.3.2.3	Determine Pedestrian Detector Data Active Detectors	M	Yes	
		3.5.3.2.4	Monitor Active Pedestrian Detector Status	M	Yes	
2.5.3.3	Monitor Detector Health			O	Yes / No	
		3.5.3.3.1.1	Monitor Vehicle Detector Alarm Status	M	Yes	

Protocol Requirements List (PRL)						
User Need ID	User Need	FR ID	Functional Requirement	Conformance	Support	Additional Specifications
		3.5.3.3.1.2	Monitor Vehicle Detector No Activity Fault	M	Yes	
		3.5.3.3.1.3	Monitor Vehicle Detector Maximum Presence Fault	M	Yes	
		3.5.3.3.1.4	Monitor Vehicle Detector Erratic Output Fault	M	Yes	
		3.5.3.3.1.5	Monitor Vehicle Detector Communications Fault	M	Yes	
		3.5.3.3.1.6	Monitor Vehicle Detector Configuration Fault	M	Yes	
		3.5.3.3.2.1	Monitor Loop Vehicle Detector Watchdog Failure	O	Yes / No	Loop:
		3.5.3.3.2.2	Monitor Loop Vehicle Detector Open Loop Failure	O	Yes / No	
		3.5.3.3.2.3	Monitor Loop Vehicle Detector Shorted Loop Fault	O	Yes / No	
		3.5.3.3.2.4	Monitor Loop Vehicle Detector Excessive Change Fault	O	Yes / No	
		3.5.3.3.3.1	Monitor Pedestrian Detector Alarm Status	M	Yes	
		3.5.3.3.3.2	Monitor Pedestrian Detector No Activity Fault	M	Yes	
		3.5.3.3.3.3	Monitor Pedestrian Detector Maximum Presence Fault	M	Yes	
		3.5.3.3.3.4	Monitor Pedestrian Detector Erratic Output Fault	M	Yes	
		3.5.3.3.3.5	Monitor Pedestrian Detector Communications Fault	M	Yes	
		3.5.3.3.3.6	Monitor Pedestrian Detector Configuration Fault	M	Yes	
		3.5.3.3.3.7	Monitor Pedestrian Services	M	Yes	
2.5.3.4	Control Detectors			O	Yes / No	
		3.5.3.4.1	Control Vehicle Detector Reset	M	Yes	
		3.5.3.4.2	Control Pedestrian Detector Reset	M	Yes	
		3.5.3.4.3	Control Vehicle Detector Actuation	O	Yes / No	

Protocol Requirements List (PRL)						
User Need ID	User Need	FR ID	Functional Requirement	Conformance	Support	Additional Specifications
		3.5.3.4.4	Control Pedestrian Detector Actuation	O	Yes / No	
2.5.3.5	Manage Detector Data			O	Yes / No	
2.5.3.6	Monitor Detector Data from External Detectors					
2.5.4 (CV)	Manage Connected Vehicles Interface			O	Yes / No	
2.5.4.1	Connected Vehicle Interface: Management Station – ASC Interface			M	Yes / No	
2.5.4.1.1	Manage CV Application Process Interface			M	Yes	
		3.5.4.1.1.1	Configure RSU Interface	M	Yes	
		3.5.4.1.1.2	Configure Logical RSU Ports	M	Yes	
		3.5.4.1.1.3	Configure RSU Interface Polling Period	O	Yes / No	
2.5.4.1.2	Manage CV Application Process Interface Watchdog			O	Yes / No	
		3.5.4.1.2.1	Configure RSU Interface Watchdog	M	Yes	
		3.5.4.1.2.2	Monitor RSU Interface Watchdog Timer	M	Yes	
2.5.4.1.3	Manage Signal Phase and Timing Data			CV:M	Yes / NA	
		3.5.4.1.3.1	Enable Signal Phase and Timing Data	M	Yes	
		3.5.4.1.3.2	Retrieve Signal Phase and Timing Generation Time	O	Yes / No	
		3.5.4.1.3.3.1.1	Monitor Movement Minimum End Time	M	Yes	
		3.5.4.1.3.3.1.2	Monitor Movement Maximum End Time	M	Yes	
		3.5.4.1.3.3.1.3	Monitor Movement Likely End Time	O	Yes / No	
		3.5.4.1.3.3.1.4	Monitor Movement Likely End Time Confidence	O	Yes / No	
		3.5.4.1.3.3.1.5	Monitor Movement Next Occurrence	M	Yes	
		3.5.4.1.3.3.1.6	Monitor Next Movement Minimum End Time	M	Yes	
		3.5.4.1.3.3.1.7	Monitor Next Movement Maximum End Time	M	Yes	
		3.5.4.1.3.3.1.8	Monitor Next Movement Start Time	M	Yes	

Protocol Requirements List (PRL)						
User Need ID	User Need	FR ID	Functional Requirement	Conformance	Support	Additional Specifications
		3.5.4.1.3.3.1.9	Determine Maximum Number of Movement Events	M	Yes	
		3.5.4.1.3.3.2.1	Configure Queue Detectors for Movement Assistance	MvtQueue:M	Yes / NA	
		3.5.4.1.3.3.2.2	Configure Pedestrian Detectors for Movement Assistance	MvtConflict:O.11 (1..*)	Yes / No / NA	
		3.5.4.1.3.3.2.3	Configure Bicycle Detectors for Movement Assistance	MvtConflict:O.11 (1..*)	Yes / No / NA	
		3.5.4.1.3.3.3.1 (MvtQueue)	Monitor Lane Connection Queue Length	O	Yes / No	
		3.5.4.1.3.3.3.2 (MvtConflict)	Monitor Lane Connection Traveler Detection	O	Yes / No	
		3.5.4.1.3.3.4.1 (SpdAdvice)	Configure Advisory Speed Type	O	Yes / No	
		3.5.4.1.3.3.4.2	Configure Advisory Speed	SpdAdvice:O	Yes / No / NA	
		3.5.4.1.3.3.4.3	Configure Advisory Speed Zone	SpdAdvice:O	Yes / No / NA	
		3.5.4.1.3.3.4.4	Configure Advisory Speed Vehicle Type	SpdAdvice:O	Yes / No / NA	
		3.5.4.1.3.3.5	Monitor Movement State	M	Yes	
		3.5.4.1.3.3.6	Monitor Next Movement State	M	Yes	
		3.5.4.1.3.3.7	Monitor Movement Status	M	Yes	
		3.5.4.1.3.4.1	Configure Concurrent Enabled Lanes	M	Yes	
		3.5.4.1.3.4.2	Configure Enabled Lanes by Time of Day	M	Yes	
		3.5.4.1.3.4.3	Determine Lanes Enabled	M	Yes	
		3.5.4.1.3.4.4	Command Enabled Lanes	M	Yes	
		3.5.4.1.3.5	Enable Signal Phase and Timing Data Exchange	M	Yes	
		3.5.4.1.3.6	Configure Road Authority	M	Yes	
		3.5.4.1.3.7.1	Monitor Manual Control Indication	M	Yes	
		3.5.4.1.3.7.2	Monitor Stop Indication	M	Yes	
		3.5.4.1.3.7.3	Monitor Failure Flash Indication	M	Yes	
		3.5.4.1.3.7.4	Monitor Preemption Operation Indication	M	Yes	
		3.5.4.1.3.7.5	Monitor Priority Operation Indication	M	Yes	

Protocol Requirements List (PRL)						
User Need ID	User Need	FR ID	Functional Requirement	Conformance	Support	Additional Specifications
		3.5.4.1.3.7.6	Monitor Fixed Time Control Indication	M	Yes	
		3.5.4.1.3.7.7	Monitor Non-Fixed Time Control Indication	M	Yes	
		3.5.4.1.3.7.8	Monitor Standby Operation Indication	M	Yes	
		3.5.4.1.3.7.9	Monitor Controller Failure	M	Yes	
		3.5.4.1.3.7.10	Monitor MAP Message Validity	M	Yes	
		3.5.4.1.3.7.11	Monitor SPaT Data Validity	M	Yes	
		3.5.4.1.3.8	Mark SPaT Invalid - Controller	M	Yes	
		3.5.4.1.3.9	Mark SPaT Invalid - Port	O	Yes / No	
		3.5.4.1.3.10	Mark MAP Message Invalid - Controller	M	Yes	
		3.5.4.1.3.11	Mark MAP Message Invalid - Port	O	Yes / No	
		3.5.4.1.3.12.1	Determine Maximum Number of Signal Groups	M	Yes	
		3.5.4.1.3.12.2	Configure Signal Group Intersection Mapping	M	Yes	
		3.5.4.1.3.12.3	Configure Signal Group Control Source	M	Yes	
		3.5.4.1.3.12.4	Configure Signal Group Indication Types	M	Yes	
		3.5.4.1.3.12.5	Configure Signal Group Permissive Control Source	M	Yes	
		3.5.4.1.3.12.6	Configure Signal Group Lanes	M	Yes	
		3.5.4.1.3.12.7	Determine Maximum Number of Signal State Entries	M	Yes	
3.5.4.1.3.12.8	Configure Signal State Parameters	M	Yes			
2.5.4.1.4	Manage Assured Green Period			O	Yes / No	
		3.5.4.1.4.1	Configure Assured Green Period			
		3.5.4.1.4.2	Configure RLVW Detection Zone Detector Input			
		3.5.4.1.4.3	Monitor Assured Green End Time			
2.5.4.2	Connected Vehicle Interface: ASC – CV Application Process Interface			CV:M	Yes / NA	
2.5.4.2.1	Exchange Current and Next Movement Information			CV:M	Yes / NA	

Protocol Requirements List (PRL)						
User Need ID	User Need	FR ID	Functional Requirement	Conformance	Support	Additional Specifications
		3.5.4.2.1.1.1	Provide UPER-encoded SPaT Message			
		3.5.4.2.1.1.2	Provide Movement Time Point	M	Yes	
		3.5.4.2.1.1.3	Provide Movement State	M	Yes	
		3.5.4.2.1.1.4	Provide Movement Minimum End Time	M	Yes	
		3.5.4.2.1.1.5	Provide Movement Maximum End Time	M	Yes	
		3.5.4.2.1.1.6	Provide Movement Likely End Time	O	Yes / No	
		3.5.4.2.1.1.7	Provide Movement Likely End Time Confidence	O	Yes / No	
		3.5.4.2.1.1.8	Provide Next Movement State	M	Yes	
		3.5.4.2.1.1.9	Provide Next Movement Minimum End Time	M	Yes	
		3.5.4.2.1.1.10	Provide Next Movement Maximum End Time	M	Yes	
		3.5.4.2.1.1.11	Provide Next Movement Start Time	M	Yes	
		3.5.4.2.1.2.1	Provide Lane Connection Queue Length	O	Yes / No	
		3.5.4.2.1.2.2	Provide Lane Connection Traveler Detection	O	Yes / No	
		3.5.4.2.1.3.1	Provide Advisory Speed Type	O	Yes / No	
		3.5.4.2.1.3.2	Provide Advisory Speed	O	Yes / No	
		3.5.4.2.1.3.3	Provide Advisory Speed Zone	O	Yes / No	
		3.5.4.2.1.3.4	Provide Advisory Speed Vehicle Type	O	Yes / No	
		3.5.4.2.1.4	Provide Road Authority ID	M	Yes	
		3.5.4.2.1.5	Provide Signal Phase and Timing Intersection Status	M	Yes	
		3.5.4.2.1.6	Provide SPaT Information to a CV Application Process	M	Yes	
		3.6.5.1	SPaT Maximum Transmission Start Time	M	Yes / NA	The Maximum Transmission Start Time for all SPAT data shall be ___ milliseconds (Default=10).

Protocol Requirements List (PRL)						
User Need ID	User Need	FR ID	Functional Requirement	Conformance	Support	Additional Specifications
		3.6.5.2	Movement Time Point Minimum Transmission Rate	M	Yes / NA	The Movement Time Point Minimum Transmission Rate shall be once per _____ milliseconds (Default=100).
		3.6.5.3	SPaT Maximum Transmission Rate	M	Yes / NA	
		3.6.5.4	SPaT Time Accuracy	M	Yes / NA	
2.5.4.2.2	Exchange Next Occurrence of a Movement			CV:M	Yes / NA	
		3.5.4.2.2.1	Provide Movement Next Occurrence	M	Yes	
		3.6.5.1	SPaT Maximum Transmission Start Time	M	Yes / NA	The Maximum Transmission Start Time for all SPAT data that changed shall be _____ milliseconds (Default=10).
		3.6.5.2	Movement Time Point Minimum Transmission Rate	M	Yes / NA	The Movement Time Point Minimum Transmission Rate shall be once per _____ milliseconds (Default=100).
		3.6.5.3	SPaT Maximum Transmission Rate	M	Yes / NA	
		3.6.5.4	SPaT Time Accuracy	M	Yes / NA	
2.5.4.2.3	Exchange Presence of Connected Devices			O	Yes / No	
		3.5.4.2.3.1	Retrieve BSMs	O.12(1..*)	Yes / No / NA	
		3.5.4.2.3.2	Retrieve PSMs	O	Yes / No	
		3.5.4.2.3.3	Retrieve Actuation Report	O.12(1..*)	Yes / No / NA	
		3.5.4.2.3.4	Retrieve Detection Report	O	Yes / No	
2.5.4.2.4	Exchange Roadway Geometrics Information			O	Yes / No	
		3.5.4.2.4.1	Retrieve MAP Plan in Effect	M	Yes / NA	
		3.5.4.2.4.2	Confirm MAP Plan Compatibility	M	Yes	
2.5.4.3	ASC – ECLA Interface			O	Yes / No	
		3.5.4.3.1	Retrieve Next Movement Start Time from an ECLA	M	Yes	
		3.5.4.3.2	Retrieve Current Minimum End Time from an ECLA	M	Yes	
		3.5.4.3.3	Retrieve Current Maximum End Time from an ECLA	M	Yes	
		3.5.4.3.4	Retrieve Current Likely End Time from an ECLA	M	Yes	

Protocol Requirements List (PRL)						
User Need ID	User Need	FR ID	Functional Requirement	Conformance	Support	Additional Specifications
		3.5.4.3.5	Retrieve Current Likely End Time Confidence from an ECLA	M	Yes	
		3.5.4.3.6	Retrieve Next Movement State from an ECLA	M	Yes	
		3.5.4.3.7	Retrieve Next Minimum End Time from an ECLA	M	Yes	
		3.5.4.3.8	Retrieve Next Maximum End Time from an ECLA	M	Yes	
		3.5.4.3.9	Retrieve Next Movement Start Time from an ECLA	M	Yes	
2.5.5	Backward Compatibility Features					
2.6	Security			M	Yes	
2.6.1	Manage Authentication			M	Yes	
2.6.2	Manage Accessibility			M	Yes	
2.6.3	Manage Users			M	Yes	
		ISO 26048-1§ 8.17.2.1	Configure a security group	M	Yes	
		ISO 26048-1§ 8.17.2.2	Configure a MIB view	M	Yes	
		ISO 26048-1§ 8.17.2.3	Configure access rights for group	M	Yes	
		ISO 26048-1§ 8.17.2.4	Configure security group configuration	M	Yes	
		ISO 26048-1§ 8.17.2.5	Confirm a MIB view	M	Yes	
		ISO 26048-1§ 8.17.2.6	Confirm access rights for group	M	Yes	
		ISO 26048-1§ 8.17.2.7	Determine device contexts	M	Yes	
2.6.4	Log User Access			O	Yes / No	

Protocol Requirements List (PRL)						
User Need ID	User Need	FR ID	Functional Requirement	Conformance	Support	Additional Specifications
		ISO 26048-1§ 8.1.3.1	Validate access upon action activation	M	Yes	
		ISO 26048-1§ 8.1.3.2	Validate access upon action being called	M	Yes	
		3.6.1	Response Time for Requests	M	Yes	The Response Time for all requests shall be ____ milliseconds (5-500: Default=25).
2.6.5	Manage ASC Interface Security			O	Yes / No	
2.6.5.1	Manage Security for the ASC to RSU Interface					
2.6.5.2	Manage Security for Other ASC Interfaces					

3.4 Architectural Requirements

Requirements for communication capabilities follow.

3.4.1 Support Basic Communications Requirements

The requirements to respond to requests follow. In addition, some requirements to determine the communications capabilities are found in Sections 8.6 of ISO 26048-1 – the specific requirements can be found under User Need 2.4.1, Provide Live Data in Table 5 Protocol Requirements List (PRL)

3.4.1.1 Retrieve Data

Upon request from a management station, the ASC shall provide the data requested.

3.4.1.2 Deliver Data

Upon request from a management station, the ASC shall receive the data (e.g., configuration data, commands, etc.) provided.

3.4.1.3 Explore Data

Upon request from a management station, the ASC shall allow dynamic discovery of the data concepts and data instances supported by the ASC.

3.4.1.4 SNMP Requirements

The requirements for SNMP conformance follow. In addition, some requirements to monitor and control the ASC are found in Section 8.6 of ISO 26048-1.

3.4.1.4.1 Monitor SNMP Information

Upon request from a management station, the ASC shall return basic instrumentation and control information of the SNMP device.

Note: The following objects are still supported in RFC 1907: snmpInPkts, snmpInBadVersions, snmpInBadCommunityNames, snmpInBadCommunityUses, snmpInASNParseErrs, snmpEnableAuthenTraps, snmpSilentDrops, snmpProxyDrops

3.4.2 Manage Data Blocks Requirements

The requirements to manage sets of data so that data may be exchanged more efficiently over communications networks follow. In addition, some requirements to manage sets of data are found in Sections 8.8.2 and 8.8.3 of ISO 26048-1 – the specific requirements can be found under User Need 2.4.2, Provide Pre-Defined Data Blocks in Table 5 Protocol Requirements List (PRL).

3.4.2.1 Store Pre-defined Compressed Data Blocks

Upon request from a management station, the ASC shall store pre-defined sequences (blocks) of configuration data. Each pre-defined block contains configuration parameters for a functional area associated with the operation and management of an ASC. The pre-defined blocks are used to reduce the upload and download times of data between a management station and the ASC or between an ASC and another device. Several pre-defined blocks are defined by this standard.

Each block contains configuration parameters for a functional area associated with the operation and management of an ASC. These blocks allow a transportation manager to select what sets of configuration

data need to be exchanged with the ASC in a bandwidth efficient manner, either because the data is exchanged often, or the set otherwise requires a large amount of bandwidth.

3.4.3 Support Logged Data Requirements

The requirements to download logged data from an ASC follow. The logged data may be used for different purposes and by different groups, so to provide the logged data in an organized manner, the logged data may be stored in different event logs (classes) managed by different owners. Each event type defines the condition(s) when an event is logged. The requirements for monitoring the operating environment of the cabinet with the ASC are found in Section 8.2.2 of ISO 26048-1 – the specific requirements can be found under User Need 2.4.3, Provide for Log Data Local Storage and Retrieval in Table 5 Protocol Requirements List (PRL).

3.4.4 Support Database Management

The requirements to manage the ASC database follow. The requirements to manage the ASC database are found in Section 8.16 of ISO 26048-1 – the specific requirements can be found under User Need 2.4.4, Provide for Database Management in Table 5 Protocol Requirements List (PRL).

3.4.5 Support Condition-based Exception Reporting

An ASC system may wish to transmit data to another system when specific events occur. The requirements to configure notifications and acknowledgements in an ASC and to notify other systems are found in Section 8.10.1 of ISO 26048-1 – the specific requirements can be found under User Need 2.4.5, Condition-based Exception Reporting in Table 5 Protocol Requirements List (PRL).

3.5 Data Exchange and Operational Environment Requirements

Data exchange requirements for an ASC follows.

To reduce the number of requirements stated, it is assumed that if a requirement to configure or store a value exists, an implicit requirement exists that when a management station requests confirmation of a value, the ASC will return that value.

3.5.1 ASC Configuration Management Requirements

The requirements for managing an ASC configuration follow.

3.5.1.1 Manage ASC Information Requirements

The requirements to manage the physical location and other identification details of an ASC follow. In addition, some requirements to describe the ASC are found in Sections 8.2.2.1.1, 8.2.2.1.2, 8.6, and 8.11 of ISO 26048-1 – the specific requirements can be found under User Need 2.5.1.1, Manage Device Identity in Table 5 Protocol Requirements List (PRL).

3.5.1.1.1 Configure ASC Location

This functional requirement is only needed if there is no external GNSS or similar geopositioning device attached to the ASC to allow a management station to set the location of the ASC. Upon request from the management station, the ASC shall store the location of the ASC, as provided within the request. The ASC location consists of the latitude, longitude, and elevation. The latitude and longitude are measured in micro degrees (10^{-6} degrees) based on the WGS-84 (World Geodetic System 1984). The elevation of the ASC is in meters above mean sea level, and is measured to the base of the structure for a permanent ASC.

3.5.1.1.2 Configure ASC Location - Antenna Offset

If an external GNSS or similar geopositioning device is attached to the ASC, upon request from the management station, the ASC shall store the offset in elevation, in meters, between the antenna used by a GNSS or similar geopositioning device and the base of the structure for a permanent ASC. A geographic position provided by a GNSS (or similar) device is usually based on the location of the antenna. Generally, the longitude and latitude of the antenna is the same location as the ASC, but the height of the antenna will normally be higher than the base of the structure. This requirement corrects the GNSS reading, which includes the elevation of the antenna, for the base of the structure.

3.5.1.1.3 Determine Supported Standards

Upon request from a management station, the ASC shall return the NTCIP standards which it supports.

3.5.1.2 Manage Communications Requirements

An ASC typically has several communications ports for exchanging information with the cabinet subsystems and other external devices in the cabinet. There are different potential ports configurations that might be used including Ethernet, RS-232, and dial-up, as well as ports to connect to wireless infrastructures such as Wi-Fi, cellular, or others. Additionally, an ASC is likely to have at least two ports for external communications (one for communications with a central management system and one to connect to a local port to be used by authorized persons interacting with the ASC directly), but additional ports might be present, particularly for interconnecting neighboring controllers and/or when connecting to a roadside unit.

3.5.1.2.1 Configure Communications Requirements

The requirements for configuring the communications ports in the ASC follow.

3.5.1.2.1.1 Enable/Disable Communications Port

Upon request from a management station, an ASC shall enable or disable a communications port on the ASC.

3.5.1.2.1.2 Configure ASC Ethernet Ports

Upon request from a management station, an ASC shall store the communications parameters of an Ethernet port on the ASC including information such as the IP address, MAC address, gateway address, subnet mask and whether DHCP is enabled.

3.5.1.2.1.3 Configure ASC Asynchronous Serial Ports

Upon request from a management station, an ASC shall store the communications parameters of the asynchronous serial port on the ASC including information such as the baud rate, full duplex or half duplex, and the port address.

3.5.1.2.1.4 Configure ASC Synchronous Serial Ports

Upon request from a management station, an ASC shall store the communications parameters of a synchronous serial port on the ASC including information such as the baud rate, full duplex or half duplex, and the port address.

3.5.1.2.1.5 Configure ASC Communications Protocol - Serial Ports

Upon request from a management station, an ASC shall store the communications protocol to be used on each individual communications port in the ASC. Valid values are NTCIP, Port 1, Serial Bus #1, Serial Bus #3, and Console. This requirement applies to only serial ports supported by the ASC.

3.5.1.3 Manage Cabinet Environment Requirements

An ASC system includes a cabinet within which the controller subsystems reside including the controller unit. Each cabinet has at least one door, and many cabinets have fans that turn on when temperature thresholds have been reached. Up to 255 different cabinet environmental devices can be monitored. The requirements to manage the cabinet environment follow. In addition, some requirements for monitoring the operating environment of the cabinet with the ASC are found in Section 8.2 of ISO 26048-1 – the specific requirements can be found under User Need 2.5.1.3, Manage Cabinet Environment in Table 5 Protocol Requirements List (PRL).

3.5.1.3.1 Configure ATC Cabinet Device LEDs

Upon request from a management station, the ASC shall store the mode of the LED displays in an ATC cabinet. This requirement allows a management station to control the operation of LEDs on cabinet devices. Valid values are other, on, and off.

3.5.1.4 Monitor Power Requirements

The requirements to monitor the status of the power-provision-related equipment associated with the ASC cabinet follow. In addition, some requirements for monitoring power are found in Section 8.2 of ISO 26048-1 – the specific requirements can be found under User Need 2.5.1.4, Monitor Power in Table 5 Protocol Requirements List (PRL).

3.5.1.4.1 Determine Power Source

Upon request from a management station, an ASC shall return the current power source for the ASC cabinet. Valid values are AC Power, generator, solar, battery-UPS, 48Vdc, and 24Vdc.

3.5.1.5 Manage Operational Performance Data Requirements

Operational performance data consists of frequent snapshots of signal operations data and detector data measured by the ASC and allows the management station to view the temporal relationship between signal indications and traveler arrivals. The requirements to manage the collection and retrieval of high-resolution operational data are found in Section 8.12 of ISO 26048-1 – the specific requirements can be found under User Need 2.5.1.5, Retrieve Operational Performance Data in Table 5 Protocol Requirements List (PRL).

3.5.1.6 Manage Auxiliary External Inputs/Outputs Requirements

The requirements to support the monitoring and control of auxiliary external devices or functions, also called supplemental roadside sensors and actuator (SRSA) ports, to satisfy other transportation operational needs follow. SRSA ports may interface with sensors or actuators such as float switches that indicate if there is flooding in and around the ASC cabinet. The requirements to monitor and control SRSA ports are found in Section 8.15.2 of ISO 26048-1 – the specific requirements can be found under User Need 2.5.1.6, Manage Auxiliary External Inputs/Outputs in Table 5 Protocol Requirements List (PRL). ISO 26048-1 defines separate requirements for cabinet door sensors, temperature sensors, humidity sensors, fans, and heater, so these requirements do not consider those sensors or devices.

3.5.1.7 Manage Database Operations

The requirements to manage an ASC database, which is required for consistency checks of certain objects, follow. The requirement to identify any change to the field device's configuration is found in Section 8.6.2.13 of ISO 26048-1 – the specific requirements can be found under User Need 2.5.1.7, Manage Database in Table 5 Protocol Requirements List (PRL).

3.5.1.7.1 Determine Unique Deployment Configuration Identifier

Upon request from a management station, the ASC shall return the identifier created using a checksum-creation-like approach across all configuration parameters contained in the ASC database, which the ASC creates across all configuration parameter values at powerup and updated whenever changes are made to any of the configuration parameters.

Note: While the order of the configuration parameters within the ASC database to create the unique configuration identifier is not important, the number and actual configuration parameters to be used to create the identifier is essential to determine whether any, but not which, changes to the configuration parameters contained within the ASC database have been made.

3.5.1.7.2 Determine Configuration Identifier Parameter Content

Upon request from a management station, the ASC shall return the configuration parameters being used to create configuration parameter identifier by listing all configuration parameters based on their SNMP Object Identifiers (Object OIDs) including scalar and instance indicators and starting with configuration parameter OIDs defined in the NTCIP standards and followed by any manufacturer-specific configuration parameter OIDs.

3.5.1.7.3 Configure Parameters for Creation of an Alternate Device Configuration Identifier

Upon request from a management station, the ASC shall store a set of configuration parameters that are used to create the value of an alternate device configuration identifier. This requirement allows an operator to select the configuration parameters used to generate the configuration identifier (See 3.5.1.7.1).

3.5.1.8 Manage Peer-to-Peer Connection Requirements

Peer-to-peer communications allow a ("host") ASC to use state conditions from a neighboring ("remote") NTCIP-compliant ASC or other NTCIP-compliant device as an input for coordinated signal operations.

The requirements to manage peer-to-peer communications within the ASC follow.

3.5.1.8.1 Configure Peer-to-Peer Identifier Description

Upon request from a management station, an ASC shall store a description of a NTCIP-compliant peer-to-peer connection. This text description can be used to provide information about the remote device or the trigger conditions can be received from the remote device.

3.5.1.8.2 Configure Peer-to-Peer Connection Target

Upon request from a management station, an ASC shall store the IP address and port number of the remote device that is to receive the notification that a trigger condition has occurred. Receiving the notification by the remote device triggers an action to be performed by the remote device.

No Timeout?
What about source device configuration?

3.5.1.8.3 Configure Peer-to-Peer Connection Trigger Conditions

Upon request from a management station, an ASC shall store the trigger conditions that generates a notification to a remote device. The trigger conditions consist of a trigger test, the value(s) to be tested, the frequency for sampling, and the duration (in tenths of a second) that the value(s) must remain true. Valid trigger tests are onChange, greaterThan, lessThan, equal, notEqual, creation of, and deletion of. hysteresis, periodic integerBitwiseAnd, and octetBitwiseAnd.

3.5.1.8.4 Configure Peer-to-Peer Connection Action

Upon request from a management station, an ASC shall store the action(s) to be performed when it receives a notification from a trusted remote device. Note: how does the management station configure if a remote device is trusted.

3.5.1.8.5 Determine Maximum Number of Peer-to-Peer Connections

Upon request from a management station, the ASC shall return the maximum number of trigger conditions supported by the ASC.

3.5.1.9 Manage Signal Monitoring Unit Interface Requirements

The requirements to configure the interface between the ASC and the Signal Monitoring Unit follow.

3.5.1.9.1 Enable/Disable Monitoring of the Flash State from the Signal Monitoring Unit

Upon request from a management station, the ASC shall store if the ASC is to monitor the flash state of the cabinet as provided by the signal monitoring unit (may be based on SMU type). This requirement allows the ASC to share the flash state of the cabinet, as reported by the SMU, with the management station, such as a traffic management system.

3.5.1.9.2 Enable/Disable Monitoring of Channel Voltage from the Signal Monitoring Unit

Upon request from a management station, the ASC shall store if the ASC is to monitor the voltage on a channel as provided by the signal monitoring unit (may be based on SMU type). This requirement allows the ASC to share the measured voltage on a channel, as reported by the SMU, with the management station, for preventative maintenance purposes.

3.5.1.9.3 Enable/Disable Monitoring of Channel Current from the Signal Monitoring Unit

Upon request from a management station, the ASC shall store if the ASC is to monitor the current on a channel as provided by the signal monitoring unit (may be based on SMU type). This requirement allows the ASC to share the measured current on a channel, as reported by the SMU, with the management station, for preventative maintenance purposes.

3.5.1.10 Manage Interface with External Detectors Requirements

The ASC WG agrees that the requirements for to receive detector data from an external detector should be contained in NTCIP 1209, Object Definitions for Transportation Sensor Systems (TSS).

3.5.1.11 Manage ASC Clock Requirements

The requirements to manage the ASC clock is found in Section 8.3 of ISO 26048-1 – the specific requirements can be found under User Need 2.5.1.11, Manage ASC Clock in Table 5 Protocol Requirements List (PRL).

3.5.1.12 Manage External Control Local Application State Requirements

In some scenarios, the signal timing is determined by an external device called the ECLA (See Section 2.3.4.c), which sends commands to the ASC to advance the interval at specific times determined by the ECLA. The requirements that allow a management station to configure retrieving signal timing durations and movement states from an ECLA follow.

3.5.1.12.1 Enable / Disable ECLA

Upon request from a management station, the ASC shall enable or disable exchanging information with an ECLA. return the Assured Green End Time (AGET) for a movement.

3.5.1.12.2 Configure ECLA Communications Port

Upon request from a management station, the ASC shall store the name, network address and communications port to exchange data with an ECLA.

3.5.1.12.3 Configure ECLA Polling Period

Upon request from a management station, the ASC shall store the period, in milliseconds, that the ASC exchanges data with an RSU for connected vehicle data.

3.5.2 Manage Signal Operations Management Requirements

The requirements for managing the signal operations of an ASC follow.

3.5.2.1 Manage Signal Configuration Requirements

The requirements to manage the traffic signal configurations are defined in the following paragraphs.

3.5.2.1.1 Manage Unit Configuration Requirements

The requirements to manage the unit configurations of the ASC follow.

3.5.2.1.1.1 Manage Start-Up Flash Requirements

The requirements to manage the ASC Start-Up Flash state follow.

Note: The Fault Monitor and Voltage Monitor outputs shall be inactive during the Start-Up Flash state (See NEMA TS-2).

3.5.2.1.1.1.1 Configure Start-Up Flash Mode

Upon request from a management station, the ASC shall store the Start-Up flash mode for the controller after restoration of a defined power interruption or activation of the external start input. By default, the Start-Up flash state for each signal indication is the state of a channel during Automatic Flash mode. Other options are all signal indications are flashing red via the load switch flash; and all signal indications are flashing red while overriding the Channel Flash settings.

Note: MUTCD states that "Changes from (all-red) flashing mode to steady (stop-and-go) mode shall be made by changing the flashing red indications to steady red indications followed by appropriate green indications to begin the steady mode cycle" (see FHWA MUTCD 2023 Edition, Section 4G.04.A) and "The steady red clearance interval provided

during the change from red-red flashing mode to steady (stop-and-go) mode should have a duration of 6 seconds." (see FHWA MUTCD 2023 Edition, Section 4G.04 02).

3.5.2.1.1.1.2 Configure Start-Up Flash Time

Upon request from a management station, the ASC shall store the period of time, in seconds, the ASC remains in the Start-Up flash state after the power is restored following a power interruption. The period of time the ASC is allowed to be in the start-up state is 0 to 255 seconds.

3.5.2.1.1.2 Configure Backup Time Requirements

The backup time defines the period of time to be exceeded when no SET operation to any of the system control parameters as defined in Section 5.4.3 Backup Time Parameter, after which the ASC reverts to Backup Mode. The requirements to manage the ASC backup time follow.

3.5.2.1.1.2.1 Configure Backup Time

Upon request from a management station, the ASC shall store the backup time, in seconds, as provided in the request. The backup time is a value from 0 to 16777216 seconds, with a value of 0 indicating this feature is disabled.

3.5.2.1.1.2.2 Configure User-Defined Backup Time Functions

Upon request from a management station, the ASC shall store the functions, which resets the backup timer, if any Deliver operations (e.g., SET) are received on any of the defined functions.

3.5.2.1.1.2.3 Determine Maximum Number of Functions Supported for Backup Time

Upon request from a management station, the ASC shall return the maximum number of functions that can be used to reset the user-defined backup timer in the ASC.

3.5.2.1.1.3 Enable/Disable Automatic Pedestrian Clearance Setting

Upon request from a management station, the ASC shall set the Pedestrian Clearance interval to be protected from being terminated by an Interval Advance input when Manual Control Enable is active.

NOTE: NEMA TS-2 does not allow a Yellow interval to be terminated by the Interval Advance input.

3.5.2.1.2 Manage Phase Configuration Requirements

The requirements to manage the phase configurations of the ASC follow.

Unless otherwise noted, such as a pedestrian phase, a phase may be assigned to a vehicular, transit vehicle, or bicycle movement.

3.5.2.1.2.1 Configure Phases Requirements

To manage a phase-based controller, the requirements to allow a management system to configure each defined phase follow.

3.5.2.1.2.1.1 Enable/Disable Phase

Upon request from a management station, the ASC shall store if a phase is enabled or disabled for the current configuration. A disabled phase does not provide any outputs nor respond to any phase inputs.

3.5.2.1.2.1.2 Configure Phase Minimum Green Time

Upon request from a management station, the ASC shall store the minimum amount of time the Green indication is to be displayed for a phase in seconds, between 0 and 255 seconds.

3.5.2.1.2.1.3 Configure Phase Passage Time

Upon request from a management station, the ASC shall store the extensible time of the Green indication for a phase in tenths of a second, between 0 and 25.5 seconds. The extensible time of the Green indication is the amount of time that the Green indication is extended after a vehicle actuation. The Green indication is extended until the passage timer is timed out.

3.5.2.1.2.1.4 Configure Phase Maximum Green Times

Upon request from a management station, the ASC shall store a default and up to three additional user-defined values for the maximum amount of time in seconds, from 0 to 6000 seconds, for which the vehicle phase shows a Green indication. In the absence of a serviceable conflicting call, the ASC holds the Maximum Green timer in reset unless Max Vehicle Recall is enabled for this phase, which may be overridden by external input, coordMaximumMode, or another method defined in NTCIP 1202.

3.5.2.1.2.1.5 Configure Phase Yellow Time

Upon request from a management station, the ASC shall store the amount of time the Yellow indication is to be displayed for a phase in tenths of a second from 0 to 25.5 seconds.

3.5.2.1.2.1.6 Configure Red Clearance Time

Upon request from a management station, the ASC shall store the red clearance interval for a phase in tenths of a second, from 0 to 25.5 seconds.

3.5.2.1.2.1.7 Configure Phase Red Revert Time

Upon request from a management station, the ASC shall store the minimum amount of time a Red indication is to be displayed following a yellow change interval, prior to the next Green Interval for the same phase as provided in the request. The minimum red indication for this phase is in tenths of a second, from 0 to 25.5 seconds. This requirement applies when a phase ends and the signal timing goes back to the same phase. Check definition. To reservice a phase.

3.5.2.1.2.1.8 Configure Unit Red Revert Time

Upon request from a management station, the ASC shall store the minimum amount of time a Red indication is to be displayed following a yellow change interval, prior to the next Green Interval for the same phase as provided in the request. The minimum red indication for all phases defined in the ASC is in tenths of a second, from 0.0 to 25.5 seconds.

3.5.2.1.2.1.9 Configure Added Initial Time

Upon request from a management station, the ASC shall store the amount of time for a phase, in tenths of a second, by which the ASC is to increase the variable green time period (initial time period) based on the vehicle actuations detected during the associated phase's yellow and red indications. The possible amount of added initial time is between 0 to 25.5 seconds. The value is used in conjunction with the Volume Density operation that might be used within an ASC.

3.5.2.1.2.1.10 Configure Maximum Initial Time

Upon request from a management station, the ASC shall store the maximum amount of time in seconds, from 0 to 255, that the variable green time period (initial time period) of a phase can be increased, which cannot be less than the minimum green time of the phase. (Question – do we want to increase to 6000 seconds)?

3.5.2.1.2.1.11 Configure Time Before Reduction

Upon request from a management station, the ASC shall store the Time Before Reduction period for a phase in seconds from 0 to 255. The Time Before Reduction (TBR) period begins when the phase is Green, and there is a serviceable conflicting call. The linear reduction of the allowable gap from the Passage Time begins when the TBR period or the Cars Before Reduction (CBR) is satisfied, whatever occurs first. If the serviceable conflicting call is removed while timing the TBR period, the associated internal ASC timer is reset.

3.5.2.1.2.1.12 Configure Phase Time to Reduce

Upon request from a management station, the ASC shall store the time to reduce for a phase in seconds from 0 to 255 seconds. The time to reduce is used to control the linear rate of reduction between the Passage Time and the minimum gap, as defined by NEMA TS 1 and NEMA TS 2.

3.5.2.1.2.1.13 Configure Cars Before Reduction

Upon request from a management station, the ASC shall store the Cars Before Reduction (CBR) parameter for a phase in number of vehicles, from 0 to 255. The CBR begins counting when the phase is Green, and there is a serviceable conflicting call. The linear reduction of the allowable gap from the Passage Time begins when the CBR or Time Before Reduction (TBR) period is satisfied, whatever occurs first.

3.5.2.1.2.1.14 Configure Phase Reduce By Time

Upon request from a management station, the ASC shall store a parameter to control the rate of reduction for a phase in tenths of a second, from 0 to 25.5 seconds. This parameter allows the use of an alternate time to reduce algorithm other than the linear reduction defined by NEMA TS 1 and NEMA TS 2. However, the time to reduce remains the same.

3.5.2.1.2.1.15 Configure Phase Minimum Gap Time

Upon request from a management station, the ASC shall store the minimum amount of time in tenths of seconds, from 0 to 25.5 seconds, to which the gap between vehicles can be reduced with the purpose that the phase can be terminated, if the detected gap between subsequent detector actuations is greater than this value.

3.5.2.1.2.1.16 Configure Phase Dynamic Maximum Limit

Upon request from a management station, the ASC shall store the upper limit or lower limit of the maximum allowable time of the Green indication for a phase, from 0 to 255 seconds. If the Dynamic Maximum Limit is larger than the normal maximum time of the Green Indication, it becomes the upper limit. If the Dynamic Maximum Limit is lower than the normal maximum time of the Green indication, it becomes the lower limit. The ASC disables the use of this function, if the maximum recall time or a failed detector associated with the phase is active.

3.5.2.1.2.1.17 Configure Phase Dynamic Maximum Step

Upon request from a management station, the ASC shall store the step value for increasing or decreasing the allowable maximum time of the Green indication in tenths of a second, from 0 to 25.5 seconds. If a phase maxes out twice in a row, the ASC increases the allowable maximum time of the Green indication by the step value until the upper limit of the dynamic maximum is reached. If the phase gaps out twice in a row, the ASC decreases the allowable maximum time of the Green indicated by the step value until the lower limit of the dynamic maximum value is reached. If the phase alternates between gapping out and maxing out, the ASC does not change the dynamic maximum value of the Green indication.

3.5.2.1.2.1.18 Configure Phase Start-Up State

Upon request from a management station, the ASC shall store the state for a phase after the termination of the Start-Up flash state (See Section 3.5.2.1.1.1.1). The valid phase Start-Up states are:

- a) phaseNotOn – the phase is not active and no intervals are timing.
- b) greenWalk – the phase starts at the beginning of the green and walk timing intervals.
- c) greenNoWalk – the phase starts at the beginning of the green interval with no walks.
- d) yellowChange – the phase starts at the beginning of the yellow change interval.
- e) redClear – the phase starts at the beginning of the red clearance interval

Note: MUTCD states that "Changes from (all-red) flashing mode to steady (stop-and-go) mode shall be made by changing the flashing red indications to steady red indications followed by appropriate green indications to begin the steady mode cycle" (see FHWA MUTCD 2023 Edition, Section 4G.04.A) and "The steady red clearance interval provided during the change from red-red flashing mode to steady (stop-and-go) mode should have a duration of 6 seconds." (see FHWA MUTCD 2023 Edition, Section 4G.04 02). Thus if the Start-Up flash mode is all-red, then the phase Start-Up state must be redClear.

3.5.2.1.2.1.19 Configure Automatic Flash Entry Phase

Upon request from a management station, the ASC shall store which phases are serviced before initiating Automatic Flash when Automatic Flash is called.

3.5.2.1.2.1.20 Configure Automatic Flash Exit Phase

Upon request from a management station, the ASC shall store which phases are serviced when Automatic Flash terminates.

3.5.2.1.2.1.21 Configure Call to Nonactuated 1

Upon request from a management station, the ASC shall store which phases respond if the Call to Nonactuated 1 input is active.

3.5.2.1.2.1.22 Configure Call to Nonactuated 2

Upon request from a management station, the ASC shall store which phases respond if the Call to Nonactuated 2 input is active.

3.5.2.1.2.1.23 Configure Non-Lock Detector Memory

Upon request from a management station, the ASC shall store whether a call present at the beginning of a phase's yellow time is locked.

3.5.2.1.2.1.24 Configure Minimum Vehicle Recall

Upon request from a management station, the ASC shall store if a recurring call for vehicle service exists for a phase when that phase is not in its Green interval.

3.5.2.1.2.1.25 Configure Maximum Vehicle Recall

Upon request from a management station, the ASC shall store if a call for service is created to extend the green interval to the maximum Green time.

3.5.2.1.2.1.26 Configure Soft Vehicle Recall

Upon request from a management station, the ASC shall store if a call is to be placed on a phase when all conflicting phases are in green or red dwell, and there are no serviceable conflicting calls.

In design, use enumeration for recalls (mutually exclusive)

3.5.2.1.2.1.27 Configure Dual Phase Entry

Upon request from a management station, the ASC shall store if a phase is to become active upon entry into a concurrency group, when no calls exist in its ring within its concurrency group. This is valid for multi-ring configurations only.

3.5.2.1.2.1.28 Configure Simultaneous Gap Disable

Upon request from a management station, the ASC shall store if a gapped-out phase is allowed to revert to the extensible portion of the phase. This is valid for multi-ring configurations only.

3.5.2.1.2.1.29 Configure Guaranteed Passage

Upon request from a management station, the ASC shall store if the phase operates in volume density mode. The volume density mode uses gap reduction to retain the right of way for the unexpired portion of the Passage time following the decision to terminate the green due to a reduced gap.

3.5.2.1.2.1.30 Configure Actuated Rest-in-Walk

Upon request from a management station, the ASC shall store if an actuated phase rests in Walk if there is no serviceable conflicting call at the end of the Walk time.

3.5.2.1.2.1.31 Configure Conditional Service Enable

Upon request from a management station, the ASC shall store if conditional service, as defined in NEMA TS 2 Section 3.5.3.9, is allowed. Conditional service provides an optional method for phase selection in multi-ring configurations.

3.5.2.1.2.1.32 Configure Added Initial Calculation

Upon request from a management station, the ASC shall store what detector values to use for the calculation of the variable portion of the green time (added initial time): a) the largest count value from all associated detectors or b) the sum from all associated detectors.

3.5.2.1.2.1.33 Configure Phase-to-Ring Association

Upon request from a management station, the ASC shall store the ring (number), with which the phase is associated with or if the phase is disabled.

3.5.2.1.2.1.34 Configure Phase Concurrency

Upon request from a management station, the ASC shall store the phase numbers allowed to run concurrently with the phase. Phases within the same ring cannot run concurrently.

3.5.2.1.2.1.35 Configure Yellow Change Time Before End of Pedestrian Clearance

Upon request from a management station, an ASC shall store the amount of the yellow and red change interval, from 0 to 25.5 second in tenths of a second, that may precede the end of the pedestrian clearance interval for a phase. Should it be, "Upon request from a management station, an ASC shall store the amount of time, from 0 to 25.5 second in tenths of a second, the pedestrian clearance may extend into the vehicle clearance time (yellow and red) for a phase."

3.5.2.1.2.1.36 Enable/Disable Ped-only Phase

Upon request from a management station, the ASC shall store if a pedestrian-only phase is enabled or disabled for the current configuration. A disabled pedestrian-only phase does not provide any outputs nor respond to any phase inputs.

3.5.2.1.2.1.37 Configure Pedestrian Green Time

Upon request from a management station, the ASC shall store the amount of time the pedestrian WALK indication is to be displayed for a pedestrian phase in seconds, between 0 and 255 seconds.

Note: MUTCD states that the WALK indication should be at least 4 seconds with a normal minimum duration of 7 seconds (see FHWA MUTCD 2023 Edition, Figure 4I-4 and Section 4I-06 12).

3.5.2.1.2.1.38 Configure Pedestrian Clearance Time

Upon request from a management station, the ASC shall store the amount of time the first pedestrian clearance indication is to be displayed for a pedestrian phase in seconds, between 0 and 255 seconds. The first pedestrian clearance indication is the interval following a pedestrian WALK indication and is normally a flashing-don't-walk.

3.5.2.1.2.1.39 Configure Pedestrian Phase Walk Recycle Time

Upon request from a management station, an ASC shall store if the pedestrian Walk indication is allowed to be shown again within the same pedestrian phase (after the initial pedestrian Walk, Flashing Don't Walk, and minimum Don't Walk time).

3.5.2.1.2.1.40 Configure Pedestrian Phase Don't Walk Revert Time

Upon request from a management station, the ASC shall store the minimum amount of time a pedestrian Don't Walk indication is to be displayed following a Flashing Don't Walk time, prior to the next Walk indication as provided in the request. The minimum pedestrian Don't Walk time indication for this pedestrian phase is in tenths of a second, from 0 to 25.5 seconds.

3.5.2.1.2.1.41 Configure Non-Lock Ped Detector Memory

Upon request from a management station, the ASC shall store if a pedestrian call present at the beginning of the pedestrian phase's pedestrian clearance interval (flashing don't walk) is locked.

3.5.2.1.2.1.42 Configure Pedestrian Recall

Upon request from a management station, the ASC shall store if a recurring call for pedestrian service exists for a pedestrian phase when that phase is not in its Walk interval. The ASC does not recycle the pedestrian service until a conflicting phase is serviced.

3.5.2.1.2.1.43 Configure Alternate Pedestrian Clearance Time

Upon request from a management station, the ASC shall store an alternate pedestrian clearance time for a pedestrian phase, in seconds from 0 to 255 seconds. This alternate time may be used to support an ADA pedestrian clearance time.

3.5.2.1.2.1.44 Configure Alternate Pedestrian Walk Time

Upon request from a management station, the ASC shall store the amount of time for a pedestrian phase, in seconds from 0 to 255 seconds. This alternate time may be used to support an extended Walk time period based on an ADA pedestrian detector input.

3.5.2.1.2.1.45 Configure Vehicle Phase Walk Offset Time

Upon request from a management station, an ASC shall store the amount of time, in tenths of a second, that a parallel pedestrian Walk indication starts offset to the start of the green indication for the phase. For example, MUTCD states that the (leading) Pre-WALK indication should start at least 3 seconds prior to the start of Green.

Merge two objects into one object with negative numbers?

3.5.2.1.2.1.46 Configure Advanced Green Warning

Upon request from a management station, an ASC shall store the amount of time, in tenths of a second for a period of 0 to 12.8 seconds, that an Advanced Warning Green indication is displayed before the start of the phase Green. The warning signal indication, which may be a separate signal indication or device, is placed upstream of the phase's approach and indicates that the phase Green indication is about to start or has started.

3.5.2.1.2.1.47 Configure Red Indication Advanced Warning

Upon request from a management station, an ASC shall store the amount of time, in tenths of a second for a period of 0.0 to 25.5 seconds, that an Advanced Warning Red indication is to be displayed before the start of the phase Red. The warning signal, which may be a separate signal indication or device, is placed upstream of the phase's approach and indicates that the phase Red is about to start or has started.

3.5.2.1.2.1.48 Configure Flashing Yellow Arrow Associated Vehicle Phase

Upon request from a management station, the ASC shall store the associated phase for which the Flashing Yellow Arrow indication is displayed.

3.5.2.1.2.1.49 Configure Flashing Red Arrow Associated Vehicle Phase

Upon request from a management station, the ASC shall store the associated phase for which the Flashing Red Arrow indication is displayed.

3.5.2.1.2.1.50 Configure Phase Omits

Upon request from a management station, the ASC shall store the phases that are allowed to be omitted. A phase that is enabled to be omitted might be skipped, if no demand is detected or if the ASC is to perform a particular operation.

3.5.2.1.2.1.51 Enable/Disable Phase Omit during Transition

Upon request from a management station, the ASC shall store if phases may be omitted during the transition from one timing plan to another is enabled or disabled for the current configuration. A phase that is enabled to be omitted during transition might be skipped during transition to shorten the time required to reach the transition point.

3.5.2.1.2.1.52 Configure Alternate Minimum Green Time during Transition

Upon request from a management station, the ASC shall store the alternate minimum green time for a phase, in seconds from 0 to 255 seconds, that is to be used if the correction mode has been set to Shortway or Subtract Only. The alternate minimum green cannot be less than minimum green for this phase. See 3.5.2.1.3.2.

3.5.2.1.2.1.53 Configure Alternate Minimum Walk Time during Transition

Upon request from a management station, the ASC shall store the alternate minimum Walk time, in seconds from 0 to 255 seconds, that is to be used for a pedestrian phase, if the correction mode has been set to the Shortway or Subtract Only. The alternate minimum Walk cannot be less than minimum Walk for this phase. See 3.5.2.1.3.2.

3.5.2.1.2.2 Retrieve Phase Configuration Requirements

The requirements to return the configuration parameters associated with each defined phase follow.

3.5.2.1.2.2.1 Determine Maximum Number of Phases

Upon request from a management station, the ASC shall return the maximum number of phases that can be configured within the ASC.

3.5.2.1.2.2.2 Retrieve Current Phase Configuration

Upon request from a management station, the ASC shall return the configuration parameters for all defined phases.

3.5.2.1.3 Manage Coordination Configuration Requirements

The requirements to configure the traffic signal coordination parameters of the ASC follow.

3.5.2.1.3.1 Configure Operational Mode for Coordination

Upon request from a management station, the ASC shall set the operational mode for coordination. Valid values for operational modes are:

- a) 'automatic', which provides for coordinated operation, free and flash to be determined automatically by the possible sources (i.e., system command, timebase schedule or interconnect inputs).
- b) A pattern number, which provides for coordinated operation running a (timing) pattern.
- c) 'manual free', which provides for Free operation without coordination or Automatic Flash from any source.

- d) 'manual flash', which provides for Automatic Flash without coordination or Free from any source.

3.5.2.1.3.2 Configure Correction Mode for Coordination

Upon request from a management station, the ASC shall set the coordination correction mode, which changes the offset for the coordination algorithm. Coordination corrections may be done using vendor-specific methods. Valid correction modes are:

- a) Dwell - the ASC dwells in the coordinated phase until the new offset is reached.
- b) Shortway - the ASC adds to or subtracts from the timing in a manner that limits the cycle change.
- c) Add Only - the ASC adds to the timing in a manner that limits the cycle change.
- d) Subtract Only - the ASC subtracts from the timing in a manner that limits the cycle change.

3.5.2.1.3.3 Configure Maximum Mode for Coordination Requirements

Upon request from a management station, the ASC shall store the default (unit) maximum mode for coordination. The valid maximum modes are:

- a) maxInhibit - the maximum timing settings are not used while coordination is running a pattern.
- b) maximum1 - the Maximum 1 timing is used while coordination is running a pattern.
- c) maximum2 - the Maximum 2 timing is used while coordination is running a pattern.
- d) maximum3 - the Maximum 3 timing is used while coordination is running a pattern.

A user may define a Maximum Mode for Coordination for each pattern separately (See 3.5.2.1.4.1.5). If a maximum mode for coordination is defined for a pattern, the pattern maximum mode is used.

3.5.2.1.3.4 Configure Force Mode for Coordination Requirements

The requirements to configure the force mode for coordination of the ASC, of which only one value can be active at a time, follow. A user defines a force mode for coordination on the unit level and may also define a different force mode for each phase separately. This setting of the unit-level mode is overridden if a force mode for coordination is defined for a phase.

3.5.2.1.3.4.1 Configure Unit-level Force Mode for Coordination - Floating

Upon request from a management station, the ASC shall store the default (unit) coordination process to force each non-coordinated phase to limit its time to the split time value, allowing unused split times to revert to the coordinated phase.

3.5.2.1.3.4.2 Configure Unit-level Force Mode for Coordination - Fixed

Upon request from a management station, the ASC shall store the default (unit) coordination process to force each non-coordinated phase off at a fixed position in the cycle, allowing unused split time to revert to the next phase. Clarify last coordinated phase?

3.5.2.1.3.4.3 Configure Phase-level Force Mode for Coordination - Floating

Upon request from a management station, the ASC shall store for a phase to use a coordination process that forces the non-coordinated phase to limit its time to the split time value, allowing unused split times to revert to the coordinated phase.

3.5.2.1.3.4.4 Configure Phase-level Force Mode for Coordination - Fixed

Upon request from a management station, the ASC shall store for a phase to use a coordination process that forces the non-coordinated phase off at a fixed position in the cycle, allowing unused split times to revert to the next phase.

3.5.2.1.3.5 Configure Coordination Point Requirements

The requirements to configure the coordination point for an ASC follow.

3.5.2.1.3.5.1 Configure Unit Coordination Point

Upon request from a management station, an ASC shall store the default (unit) coordination point. The valid default coordination points are:

- a) firstPhaseGreenBegin. The start of the Green indication of the first coordinated phase.
- b) lastPhaseGreenBegin. The start of the Green indication of the last coordinated phase.
- c) firstPhaseGreenEnd. The end of the Green indication of the first coordinated phase.
- d) lastPhaseGreenEnd. The end of the Green indication of the last coordinated phase.
- e) firstPhaseYellowEnd. The end of the Yellow indication of the first coordinated phase.
- f) lastPhaseYellowEnd. The end of the Yellow indication of the last coordinated phase.

3.5.2.1.3.5.2 Configure Pattern Coordination Point

A user may define a coordination point for each pattern separately. If a coordination point is defined for a pattern, the pattern coordination point is used.

Upon request from a management station, the ASC shall store the coordination point for a timing pattern. The valid coordination points for a timing pattern are:

- a) unitCoordSyncPoint. The unit coordination point.
- b) firstCoordPhsGrnBegin. The start of the Green indication of the first coordinated phase.
- c) lastCoordPhsGrnBegin. The start of the Green indication of the last coordinated phase.
- d) firstCoordPhsGrnEnd. The end of the Green indication of the first coordinated phase.
- e) lastCoordPhsGrnEnd. The end of the Green indication of the last coordinated phase.
- f) firstCoordPhsYelEnd. The end of the Yellow indication of the first coordinated phase.
- g) lastCoordPhsYelEnd. The end of the Yellow indication of the last coordinated phase.

3.5.2.1.4 Manage Phase-Based Timing Patterns Requirements

The requirements to manage the traffic signal timing pattern parameters of the ASC follow.

3.5.2.1.4.1 Configure Phase-Based Timing Patterns Requirements

The requirements to configure the traffic signal timing patterns stored within an ASC follow.

3.5.2.1.4.1.1 Configure Pattern Cycle Time

Upon request from a management station, the ASC shall store the length of the pattern cycle in seconds, from 30 to 254 seconds. Longer cycle lengths?

If the pattern cycle time is of insufficient length to service the minimum timing parameters (Minimum Green, Walk, Pedestrian Clearance, Yellow Clearance, Minimum Red, etc.) of all phases, the ASC automatically implements Free Mode and indicate this in the ASC's alarm status. If the pattern cycle time is configured to be zero, the ASC implements the split time values for each phase's maximum green time values, assuming that the associated split table contains values greater than zero. If the pattern cycle time is configured to be 255, the ASC extends the duration for the pattern cycle time based on the value set in the Pattern Cycle Time - Extended Duration.

3.5.2.1.4.1.2 Configure Pattern Offset Time

Upon request from a management station, the ASC shall store the time in seconds, from 0 to 254 seconds that the local time zero lags the system time zero for this pattern.

If the Offset value is greater than the Pattern Cycle Time value, the ASC implements Free Mode, and indicates this in the ASC's alarm status. If the pattern offset time is configured to be 255, the ASC extends the offset time based on the value set in the Pattern Offset Time – Extended Duration.

3.5.2.1.4.1.3 Configure Pattern Split Association

Upon request from a management station, the ASC shall store the split associated with a traffic signal timing pattern.

3.5.2.1.4.1.4 Configure Pattern Sequence Association

Upon request from a management station, the ASC shall store the sequence associated with a traffic signal timing plan.

3.5.2.1.4.1.5 Configure Pattern Maximum Mode

Upon request from a management station, the ASC shall store the maximum mode for a pattern. The valid maximum modes are:

- a) coordMaximumMode. Use the default maximum mode defined by the ASC.
- b) maxInhibit. The maximum timing settings are not used while coordination is running this pattern.
- c) maximum1. The Maximum 1 timing is used while coordination is running this pattern.
- d) maximum2. The Maximum 2 timing is used while coordination is running this pattern.
- e) maximum3. The Maximum 3 timing is used while coordination is running this pattern.

3.5.2.1.4.2 Retrieve Phase-Based Timing Patterns Requirements

The requirements to retrieve the traffic signal timing patterns stored within a phase-based ASC follow.

3.5.2.1.4.2.1 Determine Maximum Number of Phase-based Timing Patterns

Upon request from a management station, the ASC shall return the maximum number of traffic signal plans / patterns that can be configured in the ASC.

3.5.2.1.4.2.2 Determine Timing Pattern Type

Upon request from a management station, the ASC shall return the organizational structure for the pattern table in the ASC. NTCIP 1202 supports three organizational types of pattern tables, defined by the number of offsets supported for each timing plan. The valid types of pattern tables are:

- a) Patterns - Stored timing patterns are unique and are not dependent on other timing patterns
- b) Offset3 - A timing plan is stored as three separate timing patterns but with (three) different offsets
- c) Offset5 - A timing plan is stored as five separate timing patterns but with (five) different offsets

Do we want to reconsider this in the design?

3.5.2.1.5 Manage Splits Configuration Requirements

The requirements to manage the phase splits within traffic signal timing plans / patterns parameters of the ASC follow.

3.5.2.1.5.1 Configure Split Requirements

The requirements to configure the phase splits to be used within the traffic signal timing plans / patterns stored within the ASC follow.

3.5.2.1.5.1.1 Configure Phase Split Time

Upon request from a management station, the ASC shall store the time, in seconds from 0 to 255 seconds that the split phase is allowed to receive, before the phase is terminated / forced off, when constant demand exists on all phases. The split time includes all phase clearance times for the associated phase.

The ASC operates differently depending on the configuration of other parameters as follows:

- a) If the ASC is operating in floating coordination force mode, the split time parameter is equal to the maximum amount a time a non-coordinated parameter may receive.
- b) If the ASC is operating in fixed coordination force mode, the allowed time may be longer, if a previous phase gapped out.
- c) If the cycle time for a pattern is zero (i.e., the ASC is in Manual Free Mode), then the split time is used as a maximum time for the phase, as long as the split time is not zero.
- d) If the sum of split times for all phases of a pattern is less than the cycle time, the ASC allocates any extra time to the coordinated phase. If the sum of split times for all phases of a pattern is greater than the defined cycle time for a pattern, then the ASC places itself into the Manual Free mode.
- e) If the ASC operates in the Manual Free mode, the local override bit of the Short Alarm is enabled.

3.5.2.1.5.1.2 Configure Phase Split Mode

Upon request from a management station, the ASC shall store that the operational phase split mode of a phase. The valid split modes are:

- a) Other. The split mode in use is not specified by the standard.
- b) None. The split mode of the phase is not operated under split mode control.
- c) Minimum Recall. The split mode of the phase is operated using the minimum recall setting, where demand is placed for the phase when the phase is not in its Green interval.
- d) Maximum Recall. The split mode of the phase is operated using the maximum recall setting, where a constant demand is placed for the phase during all phases. This setting applies for phases with vehicle, transit-only or bicycle movements.
- e) Pedestrian Recall. The split mode of the phase is operated with a pedestrian recall, or a constant demand for pedestrian service during all other phases.
- f) Maximum and Pedestrian Recall. The split mode of the phase is operated using the larger of maximum vehicle recall setting and of the pedestrian recall setting.
- g) Phase Omitted. The split mode of the phase is operated with this phase omitted.
- h) Nonactuated. The split mode of the phase is operated using a fixed split time for this phase.

3.5.2.1.5.1.3 Configure Split Coordination Phase

Upon request from a management station, the ASC shall store if a given phase is designated as the coordinated phase.

3.5.2.1.5.1.4 Configure Pre-timed Split

Upon request from a management station, an ASC shall allow a management station to configure a pre-timed split in units of seconds. Valid values are 0 to 255 seconds, in 1-second increments.

3.5.2.1.5.2 Determine Maximum Number of Phase Splits

Upon request from a management station, the ASC shall return the maximum number of phase splits, as a number from 1 to 255 splits that can be configured in the ASC.

3.5.2.1.6 Manage Ring Configuration Requirements

The requirements to manage the traffic signal timing rings of the ASC follow.

3.5.2.1.6.1.1 Configure Sequence Data

Upon request from a management station, the ASC shall store the sequential listing of valid phases to be included in a sequence plan.

3.5.2.1.6.1.2 Determine Maximum Number of Rings

Upon request from a management station, the ASC shall return the maximum number of rings, as a number from 1 to 255 rings that can be configured in the ASC.

3.5.2.1.6.1.3 Determine Maximum Number of Sequences

Upon request from a management station, the ASC shall return the maximum number of sequences, as a number from 1 to 255 sequences that can be configured in the ASC.

3.5.2.1.7 Manage Channel Configuration Requirements

The requirements to manage the channels of the ASC follow.

3.5.2.1.7.1 Configure Channel Requirements

The requirements to configure the channels within the ASC follow.

3.5.2.1.7.1.1 Configure Channel Control Source

Upon request from a management station, the ASC shall store the phase or overlap which controls each channel.

3.5.2.1.7.1.2 Configure Channel Control Type

Upon request from a management station, the ASC shall store what type of signal head is controlled by the channel. Valid types are:

- a) phaseVehicle. The channel controls a vehicle signal head using a phase. This includes bicycle and transit signal heads.
- b) phasePedestrian. The channel controls a pedestrian signal head using a phase.
- c) Overlap. The channel controls a vehicle signal head using an overlap. This includes flashing yellow arrows, flashing red arrows, as well as bicycle and transit signal head.
- d) pedOverlap. The channel controls a pedestrian signal head using an overlap.
- e) queueJump. The channel controls a signal head for a queue jump, typically used in transit signal priority.

3.5.2.1.7.1.3 Configure Channel Automatic Flash

Upon request from a management station, the ASC shall store the state of the channel during Automatic Flash. Valid states are:

- a) Flash Yellow. Flash yellow signal indication.
- b) Flash Red. Flash red signal indication.
- c) Flash Alternate Half Hertz.

3.5.2.1.7.1.4 Configure Channel Dim Enable/Disable Requirements

The requirements to enable or disable the state of a channel during the Dimming mode within the ASC follow.

3.5.2.1.7.1.4.1 Enable/Disable Channel Dim - Green

Upon request from a management station, the ASC shall store if the Green dimming is on during the Dimming mode.

3.5.2.1.7.1.4.2 Enable/Disable Channel Dim - Yellow

Upon request from a management station, the ASC shall store if the Yellow dimming is on during the Dimming mode.

3.5.2.1.7.1.4.3 Enable/Disable Channel Dim - Red

Upon request from a management station, the ASC shall store if the Red dimming is on during the Dimming mode.

3.5.2.1.7.1.4.4 Enable/Disable Channel Dim - Alternate Half Hertz

Upon request from a management station, the ASC shall store if Alternate Half Line Cycle dimming is on during the Dimming mode.

3.5.2.1.7.2 Retrieve Channel Requirements

The requirements to retrieve the channel definitions within the ASC follow.

3.5.2.1.7.2.1 Determine Maximum Number of Channels

Upon request from a management station, the ASC shall return the maximum number of channels supported by the ASC.

Note: See the appropriate hardware reference such as NEMA TS2, Caltrans TEES, or other to determine the hardware's maximum number of channels.

3.5.2.1.7.2.2 Retrieve Channel Definitions

Upon request from a management station, the ASC shall return the configuration parameters for all channels in service.

3.5.2.1.8 Manage Overlap Configuration Requirements

The requirements to manage overlaps within the ASC follow.

3.5.2.1.8.1 Configure Overlap Requirements

The requirements to configure the overlaps within the ASC follow.

3.5.2.1.8.1.1 Configure Overlap Type Requirements

The requirements to configure the overlap types used within the ASC follow.

3.5.2.1.8.1.1.1 Configure Overlap Type - Vehicle Normal

Upon request from a management station, the ASC shall store that the Overlap control type is 'Normal.'
The overlap may be assigned to vehicular, transit-only or bicycle movements.

- a) The ASC sets the overlap output to be Green, when an included overlap phase is green, and when an included overlap phase is yellow (or in the Red Clearance interval), and simultaneously another included overlap phase is next in the sequence.
- b) The overlap is yellow when an included overlap phase is yellow and simultaneously another included overlap phase is not next in the associated phase sequence.
- c) Otherwise, the overlap output is red.

3.5.2.1.8.1.1.2 Configure Overlap Type - Vehicle Minus Green and Yellow

Upon request from a management station, the ASC shall store that the Overlap control type is 'Vehicle Minus Green and Yellow.'

- a) The overlap output is green if an included overlap phase is green and an overlap modifier phase is not green, or if an included overlap phase is yellow (or in the Red Clearance interval) and simultaneously another included overlap phase is next and while an overlap modifier phase is not green.
- b) The overlap is yellow when an included overlap phase is yellow, and an overlap modifier phase is not yellow, and another included overlap phase is not next in the associated phase sequence.
- c) Otherwise, the overlap output is red.

3.5.2.1.8.1.1.3 Configure Overlap Type - Pedestrian Normal

Upon request from a management station, the ASC shall store that the Overlap control type is 'Pedestrian Normal'.

- a) The overlap output is Walk when an included overlap phase is green, and when an included overlap phase is yellow (or in the Red Clearance interval) and simultaneously another included overlap phase is next in the sequence. Upon completion of the Walk interval, the overlap enters the pedestrian clearance interval.
- b) The overlap remains in the pedestrian clearance interval or steady don't-walk when an included overlap phase is yellow and simultaneously another included overlap phase is not next in the associated phase sequence.
- c) Otherwise, the overlap output is steady don't-walk.

3.5.2.1.8.1.1.4 Configure Overlap Type - Flashing Yellow Arrow - 3 Section Head

Upon request from a management station, the ASC shall store that the Overlap control type is 'fYA3-1'.
This overlap control type is used with a 3-section signal head where the overlap output drives the green arrow, combined yellow/flashing yellow arrow, and red arrow.

- a) The overlap output is flashing yellow arrow when an overlap included phase is green and an overlap modifier phase is NOT green; or when an overlap included phase is yellow (or red clearance), an overlap included phase is next or an overlap modifier phase is next, and a modifier phase is NOT green.
- b) The overlap output is yellow when an overlap included phase is yellow, an overlap included phase is not next, and an overlap modifier phase is NOT green; or when an overlap modifier phase is yellow.

- c) The overlap output is red when an overlap included phase is red, an overlap modifier phase is NOT green, and an overlap modifier phase is NOT yellow; or when an overlap modifier phase is timing a red-clearance interval.
- d) The overlap output is green when an overlap modifier phase is green.

3.5.2.1.8.1.1.5 Configure Overlap Type - Flashing Yellow Arrow - 4 Section Head

Upon request from a management station, the ASC shall store that the Overlap control type is 'fYA4-1'. This overlap control type is used with a 4-section signal head where the overlap output drives the flashing yellow arrow, yellow and red.

- a) The overlap output is flashing yellow arrow when an overlap included phase is green and an overlap modifier phase is NOT green; or when an overlap included phase is yellow (or red clearance), an overlap included phase or an overlap modifier phase is next and an overlap modifier phase is NOT green.
- b) The overlap output is yellow when an overlap included phase is yellow, an overlap included phase is not next, and an overlap modifier phase is NOT green; and when an overlap modifier phase is yellow.
- c) The overlap output is red when an overlap included phase is red, an overlap modifier phase is NOT green, and an overlap modifier phase is NOT yellow; or when an overlap modifier phase is timing a red-clearance interval.
- d) The overlap output is blank/dark when an overlap modifier phase is green.

3.5.2.1.8.1.1.6 Configure Overlap Type - Flashing Red Arrow - 3 Section Head

Upon request from a management station, the ASC shall store that the Overlap control type is 'fRA3'. This overlap control type drives the green arrow, yellow arrow, and combined red/flashing red arrow.

- a) The overlap output is green when an overlap modifier phase is green.
- b) The overlap output is yellow when an overlap modifier phase is yellow; or when an overlap modifier phase is red and an overlap included phase is yellow.
- c) The overlap output is red when the overlap modifier and included phases are red.
- d) The overlap output is flashing red when an overlap included phase is green and an overlap modifier phase is red.

3.5.2.1.8.1.1.7 Configure Overlap Type - Flashing Red Arrow - 4 Section Head

Upon request from a management station, the ASC shall store that the Overlap control type is 'fRA4'. The overlap control type drives the yellow arrow, red arrow, and flashing red arrow.

- a) The overlap outputs are blank when the overlap modifier phase is green.
- b) The overlap output is yellow when an overlap modifier phase is yellow; or when an overlap modifier phase is red and an overlap included phase is yellow.
- c) The overlap output is red when an overlap modifier phase and an overlap included phase are red.
- d) The overlap output is flashing red when an overlap included phase is green and an overlap modifier phase is red.

3.5.2.1.8.1.1.8 Configure Overlap Type - 2 Section Transit Specific Signal Head

Upon request from a management station, the ASC shall store that the Overlap control type is 'transit-2'. The overlap control type drives a 2-section bar signal for transit vehicles using overlap green (vertical bar) and red (horizontal bar) outputs.

- a) The overlap output is green (vertical bar) when an overlap included phase is green;
- b) The overlap output is a flashing vertical bar when an overlap included phase is yellow and an overlap included phase is not next.

- c) The overlap output is red (horizontal bar) when an overlap included phase is red.

3.5.2.1.8.1.1.9 Configure Overlap Type – Minus Green Yellow Alternate

Upon request from a management station, the ASC shall store that the Overlap control type is 'Vehicle Minus Green and Yellow Alternate'.

- a) The overlap output is green when an overlap included phase is green and an overlap modifier phase is NOT green; OR when an overlap included phase is yellow (or red clearance) and an overlap included phase is next and an overlap modifier phase is NOT green and an overlap modifier phase is not next.
- b) The overlap output is yellow when an overlap included phase is yellow and an overlap modifier phase is NOT yellow and an overlap included phase is not next.
- c) The overlap output is red when the overlap green and yellow are not ON.

3.5.2.1.8.1.2 Configure Overlap Included Phases

Upon request from a management station, the ASC shall store the phase numbers that are 'included phases' for the overlap.

3.5.2.1.8.1.3 Configure Overlap Modifier Phases

Upon request from a management station, the ASC shall store the phase numbers that are modifier phases for a vehicle overlap. The modifier phase, when present, affects how the overlap responds, based on the overlap control type. For example, an active modifier phase may exclude the operation of the overlap.

3.5.2.1.8.1.4 Configure Pedestrian Modifier Phases

Upon request from a management station, the ASC shall store the phase numbers that are pedestrian modifier phases for a vehicle overlap. The pedestrian modifier phase, when active, affects how the overlap responds, based on the overlap type.

3.5.2.1.8.1.5 Configure Overlap Trailing Green

Upon request from a management station, the ASC shall store the trailing green time in seconds, from 0 to 255 seconds, which is the time that an overlap green that would normally terminate might be extended.

Note: this requirement also covers the use of a Flashing Yellow Arrow in lieu of or in addition to a Green.

3.5.2.1.8.1.6 Configure Overlap Trailing Yellow

Upon request from a management station, the ASC shall store the trailing yellow time in tenths of a second, from 0 to 25.5 seconds. When the overlap green time has been extended (see Overlap Trailing Green), then this value **determines the current length of the** overlap's yellow duration.

Note: this requirement also covers the use of a Flashing Yellow Arrow in lieu of or in addition to a Yellow.

3.5.2.1.8.1.7 Configure Overlap Trailing Red Clearance

Upon request from a management station, the ASC shall store the trailing red time in tenths of a second, from 0 to 25.5 seconds. When the overlap green time has been extended (see Overlap Trailing Green), then this value **determines the current length of the** overlap's red clearance duration.

Note: this requirement also covers the use of a Flashing Red Arrow in lieu of or in addition to a red clearance indication.

3.5.2.1.8.1.8 Configure Overlap Walk

Upon request from a management station, the ASC shall store the walk time for a pedestrian overlap in seconds, from 0 to 255 seconds.

3.5.2.1.8.1.9 Configure Overlap Pedestrian Clearance

Upon request from a management station, the ASC shall store the duration of the pedestrian clearance time in seconds, from 0 to 255 seconds.

3.5.2.1.8.2 Retrieve Overlaps Requirements

The requirements to retrieve the overlaps within the ASC follow.

3.5.2.1.8.2.1 Determine Maximum Number of Overlaps

Upon request from a management station, the ASC shall return the maximum number of overlaps, as a number from 1 to 255 channels that can be configured in the ASC.

3.5.2.1.8.2.2 Retrieve Overlap Definitions

Upon request from a management station, the ASC shall return the configuration parameters for all overlaps in service.

3.5.2.1.9 Manage Preempt Configuration Requirements

The requirements to manage the preemptions within the ASC follow.

3.5.2.1.9.1 Configure Preempts for Phase-based ASC Requirements

The requirements to configure preempts within a phase-based ASC follow.

3.5.2.1.9.1.1 Enable/Disable Preempt Inputs

Upon request from a management station, an ASC shall store the enabling or disabling of a preempt input within the ASC.

Note: Disabling preempts should be done with extreme caution.

3.5.2.1.9.1.2 Configure Preempt Control - Non-Locking Memory

Upon request from a management station, the ASC shall store if operation is enabled that does not require detector memory, meaning that the preempt does not occur, if the preempt request terminates prior to the expiration of the preempt delay time.

3.5.2.1.9.1.3 Configure Preempt Control - Override Automatic Flash

Upon request from a management station, the ASC shall store if a preempt is allowed to override automatic flash.

3.5.2.1.9.1.4 Configure Preempt Control - Preempt Override

Upon request from a management station, the ASC shall store if a preempt is allowed to override the next higher numbered preempt definition. Normally, a lower number preempt may override a higher number preempt, e.g., preempt number 1 may override preempt 2. This requirement prevents the lower number preempt from over-riding the next higher numbered preempt. For example, if preempt 1 is NOT allowed to override the next higher numbered preempt, in this case 2, then a call on preempt 1 will not override a call on preempt 2.

3.5.2.1.9.1.5 Configure Preempt Control - Flash Dwell

Upon request from a management station, the ASC shall store if the phases identified as preempt dwell phases and the overlaps identified as preempt dwell overlaps, flash Yellow during the Preempt Dwell interval. If the Flash Dwell feature is enabled, the ASC flashes all other phases and overlaps in a red indication.

3.5.2.1.9.1.6 Configure Preempt Link

Upon request from a management station, the ASC shall store the identity of a higher priority preempt (lower preempt number) to be combined with the current preempt. At the end of the preempt's Dwell Green time, the ASC automatically calls the linked preempt, which remains active until the preempt signal for the current preempt is removed. The ASC does not link a lower priority preempt (higher preempt number) or a non-valid preempt with the current preempt.

3.5.2.1.9.1.7 Configure Preempt Delay

Upon request from a management station, the ASC shall store the time, in seconds, from 0 to 600 seconds, that a preempt input might be active prior to initiating a preempt sequence. If a call for a non-locking preempt is removed prior to completion of this time, the ASC does not initiate the preempt sequence.

3.5.2.1.9.1.8 Configure Preempt Minimum Duration

Upon request from a management station, the ASC shall store the minimum duration in seconds, from 0 to 65535 seconds, that a preempt is active. The timing begins at the end of the preempt's delay time, if one is defined, otherwise the timing begins when the preempt input goes active, and prevents an exit from the preempt dwell interval until this time has elapsed.

3.5.2.1.9.1.9 Preempt Entry Configuration Requirements

The requirements to configure a preempt when the ASC enters preemption follow. The period of time is sometimes called the right-of-way transfer time.

3.5.2.1.9.1.9.1 Configure Preempt Enter Minimum Green Time

Upon request from a management station, the ASC shall store the minimum green duration for a preempt initiated transition in seconds, from 0 to 255 seconds. A preempt initiated transition does not cause the termination of an existing Green display prior to the lesser of the phase's Minimum Green Time or this preempt minimum green time. If the preempt minimum green time is set to zero, when the ASC immediately terminates the phase's Green display.

3.5.2.1.9.1.9.2 Configure Preempt Enter Minimum Walk Time

Upon request from a management station, the ASC shall store the minimum walk time for a preempt initiated transition in seconds, from 0 to 255 seconds. A preempt initiated transition does not cause the termination of an existing Walk display prior to the lesser of the phase's Pedestrian Green Time or this

preempt minimum walk time. If the preempt minimum walk time is set to zero, the ASC immediately terminates the phase's Walk display.

3.5.2.1.9.1.9.3 Configure Preempt Enter Pedestrian Clearance Time

Upon request from a management station, the ASC shall store the pedestrian clearance time for a normal Walk display terminated by a preempt initiated transition in seconds, from 0 to 255 seconds. A preempt initiated transition does not cause the termination of an existing pedestrian clearance display prior to the lesser of the phase's pedestrian clearance time or this preempt pedestrian clearance time. If the preempt enter pedestrian clearance time is set to zero, the ASC immediately terminates the phase's pedestrian clearance (Flashing Don't Walk) display.

3.5.2.1.9.1.9.4 Configure Preempt Enter Yellow Time

Upon request from a management station, the ASC shall store the duration in tenths of a second, from 0 to 25.5 seconds, of the Enter Yellow interval terminated by a preempt initiated transition. A preempt initiated transition does not cause the termination of an existing Yellow indication prior to the lesser of the phase's Yellow time or this preempt Enter Yellow time. If the preempt enter Yellow Change time is set to zero, the ASC immediately terminates the **phase's Yellow indication.**

3.5.2.1.9.1.9.5 Configure Preempt Enter Red Clearance Time

Upon request from a management station, the ASC shall store the duration in tenths of a second, from 0 to 25.5 seconds, of the Enter Red Clearance interval for a normal Red Clearance interval terminated by a preempt initiated transition. A preempt initiated transition does not cause the termination of the Red Clearance time prior to the lesser of the phase's Red Clearance time or this preempt Enter Red Clearance time. If the preempt Enter Red Clearance time is set to zero, the ASC immediately terminates the phase's Red Clearance time.

3.5.2.1.9.1.10 Preempt Track Clearance Configuration Requirements

The requirements to configure a preempt during the track clearance interval follow.

3.5.2.1.9.1.10.1 Configure Preempt Track Clearance Yellow Change Time

Upon request from a management station, the ASC shall store the duration of the Track Yellow change interval in tenths of a second, from 0 to 25.5 seconds. The lesser of the phase's Yellow Change time or this preempt Track Yellow Change time controls the yellow timing for the track clearance movement.

3.5.2.1.9.1.10.2 Configure Preempt Track Clearance Red Clearance Time

Upon request from a management station, the ASC shall store the duration of the Track Red Clearance interval in tenths of a second, from 0 to 25.5 seconds. The lesser of the phase's Red Clearance time or this preempt Track Red Clearance time controls the Red Clearance timing for the track clearance movement.

3.5.2.1.9.1.10.3 Configure Preempt Track Clearance Interval Time

Upon request from a management station, the ASC shall store the track clearance time for the defined preempt track phases in seconds, from 0 to 255 seconds. The track clearance time consists of the track clearing intervals and the clear track interval. If the preempt track clearance time is set to zero, the ASC omits the track clearance movement.

3.5.2.1.9.1.10.4 Configure Preempt Track Clearance Phases

Upon request from a management station, the ASC shall store the phases to be active for the preempt during the preempt track clearance interval.

3.5.2.1.9.1.10.5 Configure Preempt Track Clearance Overlaps

Upon request from a management station, the ASC shall store the overlaps to be active for a preempt during the preempt track clearance interval.

3.5.2.1.9.1.11 Configure Preempt Dwell Requirements

The requirements to configure a preempt during the dwell interval follow.

3.5.2.1.9.1.11.1 Configure Preempt Minimum Green Dwell Time

Upon request from a management station, the ASC shall store the minimum green time for a preempt to remain in a preempt dwell interval, in seconds, from 1 to 255 seconds. The ASC determines the phases that are active during the dwell interval green time based on the settings for the preempt dwell phases. The preempt dwell interval green duration does not terminate prior to the completion of the preempt minimum duration and the preempt minimum green dwell time, and if the preempt call is no longer present / active.

3.5.2.1.9.1.11.2 Configure Preempt Dwell Phases

Upon request from a management station, the ASC shall store the phases to be serviced by a preempt during the preempt dwell interval, which is followed by the phases served in the preemption cycling phase.

3.5.2.1.9.1.11.3 Configure Preempt Dwell Pedestrian Movements

Upon request from a management station, the ASC shall store the phases that may have their pedestrian movement(s) served by a preempt during the preempt dwell interval, which is followed by the pedestrian movements defined in the preempt cycling pedestrian list.

3.5.2.1.9.1.11.4 Configure Preempt Dwell Overlaps

Upon request from a management station, the ASC shall store the overlaps to be active for a preempt during the preempt dwell interval.

3.5.2.1.9.1.11.5 Configure Preempt Cycling Phases

Upon request from a management station, the ASC shall store the phases to be allowed to cycle during the preempt dwell interval.

3.5.2.1.9.1.11.6 Configure Preempt Cycling Pedestrian Movements

Upon request from a management station, the ASC shall store the phases with pedestrian movements to be allowed to cycle during the preempt dwell interval.

3.5.2.1.9.1.11.7 Configure Preempt Cycling Phases Sequence

Upon request from a management station, an ASC shall store the sequence of the phases that the ASC cycles through during the preempt dwell interval.

3.5.2.1.9.1.11.8 Configure Preempt Cycling Overlaps

Upon request from a management station, the ASC shall store the overlaps to be allowed to cycle during the preempt dwell interval.

3.5.2.1.9.1.12 Configure Preempt Exit Requirements

The requirements to configure a preempt when the preempt dwell interval ends follow.

3.5.2.1.9.1.12.1 Configure Preempt Exit Phases

Upon request from a management station, the ASC shall store the phases that are allowed to be active following the preempt dwell interval.

3.5.2.1.9.1.12.2 Configure Preempt Exit Overlaps

Upon request from a management station, the ASC shall store the overlaps that are allowed to be active following the preempt dwell interval.

3.5.2.1.9.1.12.3 Configure Preempt Exit Phase Strategy

Upon request from a management station, an ASC shall store the exit strategy to be used following the end of the preempt dwell interval. The valid exit strategies are:

- a) Exit to Normal Operations. The ASC immediately enters the exit phases (and overlaps?) to be active as configured following the preempt dwell interval.
- b) Return to Coordination. The ASC immediately returns to the place in the coordinated cycle where the ASC would have been had there been no preempt.
- c) Exit to Queue Delay Recovery. The ASC enters the phase with the highest demand or longest wait time, as determined by the Preempt Exit Priority Level.
- d) Return to Short Service Phase. The ASC goes to the first "short service phase", which is a phase where only the preempt minimum green time was serviced during the advanced preemption time or right-of-way transfer time (preemption entry intervals).

3.5.2.1.9.1.12.4 Configure Preempt Exit Priority Levels

Upon request from a management station, an ASC shall store the relative weights for the priority level for each phase when the Queue Delay Recovery exit strategy is used following the end of the preempt dwell interval. The relative weights are in integers, and a higher number indicates a larger weight for the demand and wait time for that phase.

3.5.2.1.9.1.13 Configure Preempt Max Presence Exceeded Requirements

The requirements to configure the actions to be taken if the preempt maximum presence time has been exceeded within the ASC follow.

3.5.2.1.9.1.13.1 Configure Preempt Maximum Presence Time

Upon request from a management station, the ASC shall store the maximum presence time in seconds, from 0 to 65535 seconds, for which a preempt can remain active. If this preempt presence time has elapsed, the call for preemption is considered invalid until a change of the preempt's state occurs (such as the preempt is no longer active). The timing begins at the end of the preempt's delay time, if one is defined, otherwise the timing begins when the preempt input goes active. If the preempt maximum presence time is set to zero, the ASC is to disable the preempt maximum presence time.

3.5.2.1.9.1.13.2 Configure Preempt Maximum Presence Exceeded

Upon request from a management station, an ASC shall store how to exit preemption if the preempt maximum presence time has been exceeded. Valid exit sequences when the maximum presence time has been exceeded are:

- a) Preempt Exit sequence. The ASC will use the exit strategy following the end of the preempt dwell interval (See 3.5.2.1.9.1.12.3).
- b) All-Red Flash. The ASC will go to all-red flash.

3.5.2.1.9.1.14 Configure Preempt Gate Description

Upon request from a management station, the ASC shall store a description for a gate that activates during preemption.

3.5.2.1.9.2 Determine Maximum Number of Preempts

Upon request from a management station, the ASC shall return the maximum number of preempts, as a number from 1 to 255, that can be configured in the ASC.

3.5.2.1.10 Manage ASC Scheduler Requirements

The ASC may be configured to use different traffic signal timing patterns based on a schedule. The requirements to manage the timing pattern schedule follow. Additional requirements to manage the ASC's scheduler functions are found in Section 8.7 of ISO 26048-1 – the specific requirements can be found under User Need 2.5.2.1.10, Manage Timing Pattern Scheduler in Table 5 Protocol Requirements List (PRL).

3.5.2.1.10.1 Configure Timebase Pattern Synchronization Time

Upon request from a management station, the ASC shall store the timebase pattern synchronization reference time, in minutes past midnight, from 0 to 65535 minutes. If this value is 65535, the start or activation time (in hours and minutes since midnight of that day) of the timebase pattern is used as the Synchronization reference by the ASC.

3.5.2.1.11 Manage Action Scheduler Requirements

The ASC may be configured to use perform a function (action) or a group of functions based on a schedule. The requirements to manage the ASC's scheduler functions are found in Section 8.7 of ISO 26048-1 – the specific requirements can be found under User Need 2.5.2.1.11, Manage Action SchedulerManage Timing Pattern Scheduler in Table 5 Protocol Requirements List (PRL).

3.5.2.1.11.1 Configure Action Scheduler Synchronization Time

Upon request from a management station, the ASC shall store the scheduler synchronization reference time, in minutes past midnight, from 0 to 65535 minutes. If this value is 65535, the start or activation time (in hours and minutes since midnight of that day) of the timebased pattern is used as the Synchronization reference by the ASC.

3.5.2.1.11.2 Configure Timebased Action - Pattern

Upon request from a management station, the ASC shall store the identity of the timing pattern that is active when the Action is active. If the timebased action pattern is set to zero, the ASC reverts to a lower priority entity such as 'interconnect' (if available).

3.5.2.1.12 Manage I/O Mapping Requirements

The ASC communicates with different Field I/O Devices in the cabinet. The number and types of Field I/O Devices depend on the transportation cabinet architecture used. The types of Field I/O Devices supported for each transportation cabinet architecture are indicated in Table 6.

Table 6 Field I/O Devices Supported

Cabinet Architecture	Field I/O Devices Supported
Model 332 Cabinet	Model 2070-2A (or equivalent) - Defined in ATC 5202 - Model 2070 Controller Standard Version 3.
NEMA TS 1 Cabinet	Model 2070-8 (or equivalent) - Defined in ATC 5202 - Model 2070 Controller Standard Version 3.
NEMA TS 2 Type 1 Cabinet	Terminal & Facilities (T&F) Bus Interface Unit (BIU) - Defined in NEMA TS 2 (R2008). Detector Bus Interface Unit (BIU) - Defined in NEMA TS 2 (R2008).
NEMA TS 2 Type 2 Cabinet	Model 2070-8 (or equivalent) - Defined in ATC 5202 - Model 2070 Controller Standard Version 3.
ATC Cabinet	Serial Interface Unit - Defined in ATC Cabinet Standard, v02

In addition to these the ASC may communicate with Auxiliary I/O devices (such as the front panel AUX switch on the 170 and 2070 controllers) and manufacturer specific custom I/O (such as 'D' connectors on TS1 controllers).

The ASC I/O mapping supports all these types of I/O devices and combinations of them to create a mapping of all I/O active at any one time. Multiple I/O mappings are supported which allow default I/O maps for different situations and cabinet configurations to be pre-loaded.

The Active I/O map is the I/O map that the ASC is currently using for signal operations. Changing the Active I/O map requires a database transaction. A new Active I/O map will only take effect if the database transaction data is successfully verified and the I/O Map Activate Conditions are satisfied (See Section 3.5.2.1.12.2.4).

The requirements to manage the Input/Output (I/O) Mapping within the ASC follow.

3.5.2.1.12.1 Configure I/O Mapping Requirements

The requirements to configure the I/O Mapping within the ASC follow.

3.5.2.1.12.1.1 Set Active I/O Map

Upon request from a management station, an ASC shall change the Active I/O map currently being used. This change is required to be made as part of a database transaction, and only if the Activate Requirements specified in section 3.5.2.1.12.2.4 are satisfied for the new I/O map to take effect.

3.5.2.1.12.1.2 Configure I/O Map Requirements

The requirements to configure an I/O Map within the ASC follow.

3.5.2.1.12.1.2.1 Configure I/O Map Description

Upon request from a management station, an ASC shall store the description for an I/O map. This description may be any text describing the I/O map such as the intended cabinet type, the intended intersection, etc.

3.5.2.1.12.1.2.2 Configure I/O Map Input Requirements

The requirements to configure the inputs for an I/O Map within the ASC follow.

3.5.2.1.12.1.2.2.1 Configure I/O Map Input Device

Upon request from a management station, an ASC shall store a value indicating the device for each input pin in an I/O map.

3.5.2.1.12.1.2.2.2 Configure I/O Map Input Device Pin

Upon request from a management station, an ASC shall store a value indicating the device pin number for each input pin in an I/O map.

3.5.2.1.12.1.2.2.3 Configure I/O Map Input Function

Upon request from a management station, an ASC shall store a value indicating the input function to be mapped to each input pin in an I/O map.

3.5.2.1.12.1.2.3 Configure I/O Map Output Requirements

The requirements to configure the outputs for an I/O Map within the ASC follow.

3.5.2.1.12.1.2.3.1 Configure I/O Map Output Device

Upon request from a management station, an ASC shall store a value indicating the device for each output pin in an I/O map.

3.5.2.1.12.1.2.3.2 Configure I/O Map Output Device Pin

Upon request from a management station, an ASC shall store a value indicating the device pin number for each output pin in an I/O map.

3.5.2.1.12.1.2.3.3 Configure I/O Map Output Function

Upon request from a management station, an ASC shall store a value indicating the output function to be mapped to each output pin in an I/O map.

3.5.2.1.12.2 Determine I/O Mapping Requirements

The requirements to retrieve the I/O Mapping within the ASC follow.

3.5.2.1.12.2.1 Retrieve Maximum Number of I/O Maps

Upon request from a management station, an ASC shall return the maximum number of I/O maps supported by the ASC.

3.5.2.1.12.2.2 Retrieve Maximum Number of I/O Map Inputs

Upon request from a management station, an ASC shall return the maximum number of I/O map inputs supported by the ASC. This is the number of inputs that the ASC can support at any one time from all input devices.

3.5.2.1.12.2.3 Retrieve Maximum Number of I/O Map Outputs

Upon request from a management station, an ASC shall return the maximum number of I/O map outputs supported by the ASC. This is the number of inputs that the ASC can support at any one time from all input devices.

3.5.2.1.12.2.4 Retrieve I/O Mapping Activate Conditions

Upon request from a management station, an ASC shall return requirements to be fulfilled for a new I/O map to take effect. These requirements may include that a cabinet door be open (indicating that a technician is at the cabinet), that the cabinet be in any flash state, that the cabinet be in all red flash, that the cabinet be in cabinet (CVM) flash, or that the ASC be restarted.

3.5.2.1.12.2.5 Retrieve I/O Mapping Input Functions

Upon request from a management station, an ASC shall return a listing of the input functions that the ASC supports for I/O mapping.

3.5.2.1.12.2.6 Retrieve I/O Mapping Output Functions

Upon request from a management station, an ASC shall return a listing of the output function that the ASC supports for I/O mapping.

3.5.2.1.12.2.7 Retrieve I/O Map Input Device Pin Status

Upon request from a management station, an ASC shall return the status of each input in an I/O map.

3.5.2.1.12.2.8 Retrieve I/O Map Output Device Pin Status

Upon request from a management station, an ASC shall return the status of each output in an I/O map.

3.5.2.1.12.2.9 Enumerate I/O Mapping Device Pin Requirements

The ASC MIB shall contain enumerations of the standard devices and their device pins that an ASC shall support. These enumerations are:

3.5.2.1.12.2.9.1 Enumerate I/O Map - FIO Inputs

The ASC shall support a default mapping of the device input pins for a Model 332 cabinet.

3.5.2.1.12.2.9.2 Enumerate I/O Map - FIO Outputs

The ASC shall support a default mapping of the device output pins for a Model 332 cabinet.

3.5.2.1.12.2.9.3 Enumerate I/O Map - TS1 Inputs

The ASC shall support a default mapping of the device input pins for a NEMA TS 1 or a NEMA TS 2 Type 2 cabinet.

3.5.2.1.12.2.9.4 Enumerate I/O Map - TS1 Outputs

The ASC shall support a default mapping of the device output pins for a NEMA TS 1 or a NEMA TS 2 Type 2 cabinet.

3.5.2.1.12.2.9.5 Enumerate I/O Map - TS2 BIU Inputs

The ASC shall support a default mapping of the device input pins for a NEMA TS 2 Type 1 cabinet.

3.5.2.1.12.2.9.6 Enumerate I/O Map - TS2 BIU Outputs

The ASC shall support a default mapping of the device output pins for a NEMA TS 2 Type 1 cabinet.

3.5.2.1.12.2.9.7 Enumerate I/O Map - ATC Cabinet SIU Inputs

The ASC shall support a default mapping of the device input pins for an ATC cabinet.

3.5.2.1.12.2.9.8 Enumerate I/O Map - ATC Cabinet SIU Outputs

The ASC shall support a default mapping of the device output pins for an ATC cabinet.

3.5.2.1.12.2.9.9 Enumerate I/O Map - Auxiliary Device Inputs

The ASC shall support a default mapping for the auxiliary input pins.

3.5.2.1.12.2.9.10 Enumerate I/O Map - Auxiliary Device Outputs

The ASC shall support a default mapping for the auxiliary output pins.

3.5.2.1.13 Manage Intra-Cabinet Communications Requirements

The requirements to manage intra-cabinet communications within the ASC follow.

3.5.2.1.13.1 Determine Serial Bus 1 Device Present

Upon request from a management station, the ASC shall return if a device is present for a Serial Bus 1 address. The ASC only transmits command frames to those devices that are present as determined by this value.

3.5.2.1.13.2 Retrieve Intra-Cabinet Communications Requirements - TS2

The requirements to retrieve intra-cabinet communications configuration in the ASC follow.

3.5.2.1.13.2.1 Determine TS2 Port 1 Device Present

Upon request from a management station, the ASC shall return if a device is present for a TS2 Port 1 address. The ASC only transmits command frames to those devices that are present as determined by this value.

3.5.2.1.13.2.2 Determine TS2 Port 1 Frame 40 Enable

Upon request from a management station, the ASC shall return if Frame 40 message to the device is enabled for a TS2 Port 1 address.

3.5.2.1.14 Manage ADA Support Requirements

The requirements to manage ADA Support in the ASC follow.

3.5.2.1.14.1 Configure ADA Support Requirements

The requirements to configure the ASC to support ADA in the ASC follow.

3.5.2.1.14.1.1 Configure APS Push Button Minimum Press Time

Upon request from a management station, the ASC shall store the time in tenths of seconds, from 0.0 to 25.5 seconds, that an Accessible Pedestrian Signal (APS) Push Button needs to be pressed as a minimum to actuate any APS features. This requirement enables the ASC to receive inputs from installed APS push buttons to actuate any APS features. MUTCD Section 4K.05, item 02 states that the push button should be pressed for 1.0 seconds or greater to actuate any APS features. A value of 0.0 indicates that the APS features are disabled.

3.5.2.1.14.1.2 Configure APS Push Button to Phase Association

Upon request from a management station, the ASC shall return a list of the phase identifiers with whom an APS push button is associated with.

3.5.2.1.14.1.3 Configure APS Extra Crossing Time

Upon request from a management station, the ASC shall store the time in **seconds**, from 0 to 255 seconds, that the pedestrian clearance time is extended, if an APS push button has been pressed for equal to or greater than the APS push button minimum press time. A value of 0 indicates no additional crossing time.

3.5.2.1.14.2 Determine Maximum Number of Pedestrian Buttons

Upon request from a management station, the ASC shall return the maximum number of pedestrian buttons supported by the device.

3.5.2.2 Monitor Signal Operations Requirements

The requirements to monitor signal operations within the ASC follow.

3.5.2.2.1 Determine Controller Health Requirements

The requirements to determine the ASC's health status follow. In addition, some requirements to monitor the status of the ASC are found in Section 8.6.2.x of ISO 26048-1 – the specific requirements can be found under User Need 2.5.2.1.11, Manage Action Scheduler in Table 5 Protocol Requirements List (PRL).

3.5.2.2.1.1 Monitor Alarm State

Upon request from a management station, the ASC shall return if a physical alarm input is active.

3.5.2.2.1.2 Monitor Preempt Active

Upon request from a management station, the ASC shall return an alarm value when any of the preemption inputs become active.

3.5.2.2.1.3 Monitor Terminal and Facilities Flash

Upon request from a management station, the ASC shall return an alarm value when either the Local Flash or the Signal Monitoring Unit Flash input becomes active.

3.5.2.2.1.4 Monitor Local Cycle Zero Alarm

Upon request from a management station, the ASC shall return an alarm value when the ASC is in coordination mode and the currently active timing plan/pattern has passed through zero. The ASC does not clear this alarm value until the alarm is read by the management station.

3.5.2.2.1.5 Monitor Local Override

Upon request from a management station, the ASC shall return an alarm value when any external input or ASC programming has prevented the device from responding to a system pattern command.

3.5.2.2.1.6 Monitor Coordination Alarm

Upon request from a management station, the ASC shall return an alarm value when the ASC is not running the called pattern without offset correction within a user-specified number of cycles from receiving the command (default = three cycles). The ASC does not cause an alarm to be set, if an offset correction requires less than the user-specified number of cycles (default = three) due to cycle overrun caused by servicing a pedestrian call.

3.5.2.2.1.7 Monitor Detector Fault

Upon request from a management station, the ASC shall return an alarm value when a detector alarm fault occurs.

3.5.2.2.1.8 Monitor Non-Critical Alarm

Upon request from a management station, the ASC shall return an alarm value when a physical alarm input is active.

3.5.2.2.1.9 Monitor Stop Time Input Alarm

Upon request from a management station, the ASC shall return an alarm value when the stop time input is active.

3.5.2.2.1.10 Monitor Cycle Fault Alarm

Upon request from a management station, the ASC shall return an alarm value when the ASC is operating in the coordinated mode and cycling diagnostics indicate that a serviceable call exists that has not been serviced for two cycles.

3.5.2.2.1.11 Monitor Coordination Fault

Upon request from a management station, the ASC shall return an alarm value when a cycle fault is in effect and the serviceable call has been serviced within two cycles after the cycle fault.

3.5.2.2.1.12 Monitor Coordination Fail Alarm

Upon request from a management station, the ASC shall return an alarm value when a Coordination Fault is in effect and a Cycle Fault occurs again within two cycles of the coordination retry.

3.5.2.2.1.13 Monitor Cycle Fail Alarm

Upon request from a management station, the ASC shall return an alarm value when the ASC is operating in non-coordinated mode as the result of either a Cycle Fault or the ASC operating in Free mode, and cycling diagnostics indicate that a serviceable call exists that has not been serviced for two cycles.

3.5.2.2.1.14 Monitor SMU Flash Alarm

Upon request from a management station, the ASC shall return an alarm value when the Signal Monitoring Unit (e.g., Malfunction Management Unit) flash remains active for a period of time exceeding the Start-Up Flash time.

3.5.2.2.1.15 Monitor Local Flash Alarm

Upon request from a management station, the ASC shall return an alarm value when the local flash input becomes active, while the Malfunction Management Unit Flash input is not active and the Flash mode was not commanded.

3.5.2.2.1.16 Monitor Local Free Alarm

Upon request from a management station, the ASC shall return an alarm value when any of the ASC's inputs and/or programming cause the ASC not to run coordination.

3.5.2.2.1.17 Monitor Coordination Active Alarm

Upon request from a management station, the ASC shall return an alarm value when coordination is active and not preempted or overridden.

3.5.2.2.1.18 Monitor Power Restart Alarm

Upon request from a management station, the ASC shall return an alarm when power returns after a power interruption. When enabled, the ASC does not clear this alarm until the alarm has been returned.

3.5.2.2.1.19 Monitor Low Battery Alarm

Upon request from a management station, the ASC shall return an alarm value when any internal standby voltage drops below sustainable levels.

3.5.2.2.1.20 Monitor Response Fault Alarm

Upon request from a management station, the ASC shall return an alarm value when a NEMA TS2 Port 1 or Serial Bus 1 monitor response frame fault occurs.

3.5.2.2.1.21 Monitor External Start

Upon request from a management station, the ASC shall return an alarm when the Controller Unit External Start becomes active.

3.5.2.2.1.22 Monitor Stop Time Alarm

Upon request from a management station, the ASC shall return an alarm value when the Controller Unit Stop Time input becomes active.

3.5.2.2.1.23 Monitor Offset Transitioning Alarm

Upon request from a management station, the ASC shall return an alarm value when the Controller Unit is performing an offset transition.

3.5.2.2.1.24 Monitor Stall Condition

Upon request from a management station, an ASC shall return if the ASC detects a stall condition based on any "critical" watchdog timer. A watchdog timer is regularly restarted by a process or service. A stall condition for a watchdog timer occurs when the watchdog timer is not restarted by the process or service after an elapsed period of time ("times out"). A "critical" watchdog timer is a watchdog timer where a stall condition on that process or service may jeopardize the continued, safe operation of the ASC. An ASC may have one or more "critical" watchdog timers within the ASC, one for the main program and perhaps for each process or service deemed "critical" for the ASC, as determined by the ASC vendor and/or the agency operating the ASC.

3.5.2.2.1.25 Monitor Memory Fault

Upon request from a management station, an ASC shall return if the ASC detects a memory fault. Memory faults include faults of the firmware, database, RAM including flash and static RAM. Faults are detected by the ASC automatically and regularly (1024 bytes per second for ROM and Non-Volatile Memory according to NEMA TS2). Faults are normally detected by comparing the automatic memory test result checksum with a pre-programmed checksum value.

3.5.2.2.1.26 Monitor Process Failure

Upon request from a management station, an ASC shall return if the ASC detects a process (task) failure.

3.5.2.2.1.27 Monitor Communications Timeout

Upon request from a management station, an ASC shall return if the ASC detects a communications timeout on an enabled communications port on the ASC. This is different than the backup timer in that the communications port timer is a communications layer function, while the backup timer is an ASC application timer. See Sections **xxxx and xxx** for requirements to monitor communications timeouts for a specific communications port.

3.5.2.2.1.28 Monitor Power Problems

Upon request from a management station, an ASC shall return if the ASC detects power problems such as brown-outs or brief blackouts (very short power failures), which do not lead to a shutdown of the ASC (complete power failures would lead to a restart of the ASC).

3.5.2.2.1.29 Monitor UPS Errors

Upon request from a management station, an ASC shall return if the communications link between the ASC and the UPS unit is failed (assuming that the ASC is configured to communicate with the UPS via an NTCIP-compliant interface), or if the UPS battery sends battery-specific alarms such as BatteryBad, BatteryLow, BatteryDepleted, or TemperatureBad (out of tolerance) to the ASC.

3.5.2.2.1.30 Monitor Scheduler Errors

An ASC shall return if the ASC is not implementing its scheduled pattern or scheduled action.

3.5.2.2.1.31 Monitor Signal Monitor Communications Error

Upon request from a management station, an ASC shall return if the ASC is configured to communicate with the MMU and the communications link is failed.

3.5.2.2.1.32 Monitor Signal Monitor Unit Presence

Upon request from a management station, an ASC shall return if an MMU is removed from the cabinet.

3.5.2.2.1.33 Monitor USB Memory Device

Upon request from a management station, an ASC shall return if a USB memory device is present on the USB port of the ASC.

3.5.2.2.1.34 Monitor ASC Cabinet Temperature Alarm

Upon request from a management station, an ASC shall return if the current temperature measured in the ASC Cabinet exceeds the temperature thresholds.

3.5.2.2.1.35 Monitor ASC Cabinet Humidity Alarm

Upon request from a management station, an ASC shall return if the current humidity measured in the ASC cabinet exceeds the humidity threshold.

3.5.2.2.1.36 Monitor Clock Failure

Upon request from a management station, the ASC shall return an alarm value when an error is detected with the ASC's internal clock.

3.5.2.2.1.37 Monitor Preempt Maximum Presence Alarm

Upon request from a management station, the ASC shall return if the preempt maximum presence timer has been exceeded. This fault indicates that a preempt call has remained active for a time period greater than the maximum time configured.

3.5.2.2.1.38 Monitor RSU Watchdog Timer

Upon request from a management station, an ASC shall return if any RSU watchdog no activity timer fault is detected. This fault indicates that no activity has been detected across any the RSU interface for a period longer than a stored threshold.

3.5.2.2.1.39 Monitor CV Certificate Faults

Upon request from a management station, the ASC shall return if faults pertaining to invalid CV certificates have been detected.

3.5.2.2.2 Retrieve Mode of Operation Requirements

The requirements to determine the ASC's mode of operations within the ASC follow.

3.5.2.2.2.1 Monitor Unit-wide General Operations Requirements

The requirements to determine the unit-wide control status information and unit-wide parameters within the ASC follow.

3.5.2.2.2.1.1 Monitor Unit Control Status

Upon request from a management station, the ASC shall return the control mode for the ASC. Valid ASC unit control states are:

- a) Other. The ASC is controlled by a source not specified by the standard.
- b) System Control. The ASC is controlled by master or central commands.

- c) System Standby. The ASC is controlled locally based on master or central command to use local control.
- d) Backup Mode. The ASC is in backup mode.
- e) Manual. The ASC is controlled by a manual selection of a timing pattern, manual free or manual flash.
- f) Timebase. The ASC is controlled by the local time base.
- g) Interconnect. The ASC is controlled by the local interconnect inputs.
- h) Interconnect Backup. The ASC is controlled by the local TBC due to invalid Interconnect inputs or loss of sync.
- i) Police Panel Control. The ASC is controlled via the police panel.
- j) System Control Remote Advance Control. The ASC is controlled by central command by issuing Holds on a Green Rest point in each phase or interval and then issues a Remote Advance Control command to advance to the next phase or interval.
- k) Manual Control. The ASC is controlled by manual advances issued by central to the next interval.

3.5.2.2.1.2 Monitor Interconnect

Upon request from a management station, the ASC shall return if the interconnect inputs operate at a higher priority than the timebase control.

3.5.2.2.1.3 Monitor Dimming Enabled

Upon request from a management station, the ASC shall return if channel dimming operates as configured. Dimming only occurs if this value or a dimming input is enabled and simultaneously an auxiliary function is defined in the timebased scheduler.

3.5.2.2.2 Monitor Unit Flash Status

Upon request from a management station, the ASC shall return its flash status. Valid flash states are:

- a) Not in flash state
- b) An automatic flash state
- c) local flash input is active, SMU Flash is not active, and Flash is not commanded by the central system.
- d) Fault monitor state
- e) SMU flash input is active
- f) Startup flash input is active
- g) Timing the preempt flash
- h) Flash for a reason not specified by the standard

Only one flash status can be active at a time.

3.5.2.2.3 Monitor Current Timing Pattern Requirements

The requirements to monitor the ASC's current timing pattern follow.

3.5.2.2.3.1 Monitor Current Pattern Status

Upon request from a management station, the ASC shall return the coordination pattern or mode currently operating in the ASC.

- a) The signal timing pattern operating in Coordination mode.
- b) The ASC is operating in Free mode.
- c) The ASC is operating in Flash mode.

3.5.2.2.2.3.2 Monitor Local Free Status

Upon request from a management station, the ASC shall return one of the following states that led to the ASC operating in local free mode.

- a) The ASC is not running in free mode.
- b) The ASC has been commanded to free mode.
- c) The ASC has been commanded to free mode but is cycling to a point to begin coordination.
- d) The ASC is not responding to coordination due to one of the ASC inputs.
- e) The ASC programming for the called pattern is to operate in the Free mode.
- f) The ASC is running in Free mode because the called pattern is invalid.
- g) The ASC is running in Free mode because the pattern cycle time is less than the amount of time needed to serve the minimum requirements of all phases.
- h) The ASC is running in Free mode because the sum of the split times is greater than the pattern cycle time.
- i) The ASC is running in Free mode because of an invalid offset. This value is reserved/not used.
- j) The ASC is running in Free mode due to a request by the ASC's internal cycling diagnostics.
- k) The ASC is running in a Free mode not specified by the standard.

The ASC can report only one state at a time.

3.5.2.2.2.3.3 Monitor Current Mode of Operation

Upon request from a management station, an ASC shall return the mode of operation in effect. Mode of operation includes normal, manual, preempt, priority, traffic adaptive, traffic responsive, free actuated, and fault.

3.5.2.2.2.3.4 Monitor Programmed Pattern

Upon request from a management station, the ASC shall return the pattern number or mode that the ASC has been programmed for. The ASC transitions to the programmed pattern at the next transition point. A value from 1 to 253 indicates the number of the programmed pattern and that the ASC is to operate in Coordination mode. Other values indicate that ASC is to operate in Free mode, or the ASC is to operate in Flash mode. The programmed pattern allows a management station to determine what pattern is to be in effect in the ASC at the next transition point, assuming that the pattern is not overridden by a higher priority command or event.

3.5.2.2.2.3.5 Monitor Pattern Source

Upon request from a management station, the ASC shall return the source of the pattern or mode that is current in effect. Valid values are

- a) Remote. The pattern / mode was commanded from the system interface.
- b) Timebased. The pattern / mode was commanded from a schedule.
- c) Front Panel. The pattern / mode was commanded from the front panel.
- d) Local. The pattern / mode was commanded via a local interface (management station).
- e) Failure / Backup Mode. The pattern / mode was caused by a Backup mode or a failure.
- f) Other. The pattern / mode was commanded from a source not specified by the standard.

3.5.2.2.2.4 Monitor Current Cycle Requirements

The requirements to monitor the current cycle information follow.

3.5.2.2.4.1 Monitor Coordination Cycle Status

Upon request from a management station, the ASC shall return the current position in the local coordination cycle of the running pattern in seconds, from 0 to 2x the maximum cycle length. This value counts down from the current pattern's cycle time to zero. This value may be greater than the current pattern's cycle time during a coordination cycle with offset correction by the amount of the correction.

3.5.2.2.4.2 Monitor Coordination Synchronization Status

Upon request from a management station, the ASC shall return the time since the system reference point for the running pattern in seconds, from 0 to 2x the maximum cycle length. This value counts from zero to current pattern's cycle time, but may exceed the current pattern's cycle time if the system reference point has changed.

3.5.2.2.4.3 Monitor Current Split

Upon request from a management station, an ASC shall return the time into the current phase, in seconds, of the current cycle in effect.

3.5.2.2.4.4 Monitor Phase End Duration

Upon request from a management station, an ASC shall return the duration of the current phase, in seconds, of the current cycle in effect.

3.5.2.2.4.5 Monitor Current Offset

Upon request from a management station, an ASC shall return the pre-timed offset currently in effect.

3.5.2.2.3 Monitor Signal Indication Requirements

The requirements to monitor the active signal indications within the ASC follow.

3.5.2.2.3.1 Monitor Active Red Phases

Upon request from a management station, the ASC shall return which phases (or overlaps) currently have an active Red indication.

3.5.2.2.3.2 Monitor Active Yellow Phases

Upon request from a management station, the ASC shall return which phases (or overlaps) currently have an active Yellow indication.

3.5.2.2.3.3 Monitor Active Green Phases

Upon request from a management station, the ASC shall return which phases (or overlaps) currently have an active Green indication.

3.5.2.2.3.4 Monitor Active Don't Walk Phases

Upon request from a management station, the ASC shall return which pedestrian phases (or overlaps) currently have an active Don't Walk indication.

3.5.2.2.3.5 Monitor Active Pedestrian Clearance Phases

Upon request from a management station, the ASC shall return which pedestrian phases (or overlaps) currently have an active Pedestrian Clearance indication.

3.5.2.2.3.6 Monitor Active Walk Phases

Upon request from a management station, the ASC shall return which pedestrian phases (or overlaps) currently have an active Walk indication.

3.5.2.2.3.7 Monitor Active Flashing Yellow Arrow Phases

Upon request from a management station, the ASC shall return which phases currently have an active Flashing Yellow Arrow indication.

3.5.2.2.3.8 Monitor Active Flashing Red Arrow Phases

Upon request from a management station, the ASC shall return which phases currently have an active Flashing Red Arrow indication.

3.5.2.2.4 Monitor Phase Status Requirements

The requirements to monitor the phases within the ASC follow.

3.5.2.2.4.1 Monitor Active Phases

Upon request from a management station, the ASC shall return which phases are currently active. A phase is active during the Green, Yellow, Red Clearance, Walk, or Pedestrian Clearance Intervals for the given phase.

3.5.2.2.4.2 Monitor Next Phases

Upon request from a management station, the ASC shall return for which phases are currently committed to be active next (after the current Active Phase terminates). The ASC determines the next phase to be serviced at the end of the Green interval of the terminating phase, if possible. If the next phase to be serviced cannot be determined at the end of the Green interval, the ASC makes the determination after the end of all vehicle change and clearance intervals.

3.5.2.2.4.3 Monitor Vehicle Calls

Upon request from a management station, the ASC shall return which phases currently have an active vehicle call.

3.5.2.2.4.4 Monitor Pedestrian Calls

Upon request from a management station, the ASC shall return which phases currently have an active pedestrian call.

3.5.2.2.5 Retrieve Current Ring Requirements

The requirements to monitor the ring control status within the ASC follow.

3.5.2.2.5.1 Monitor Ring Status

Upon request from a management station, the ASC shall return all of the current status indications, which are valid at the time this request was issued, for each configured ring. Valid ring states are:

- a) Minimum Green
- b) Extension

- c) Maximum
- d) Green Rest
- e) Yellow Change
- f) Red Clearance
- g) Red Rest
- h) Queue Jump
- i) Flashing Yellow Arrow
- j) Flashing Red Arrow
- k) Leading / Early ped Walk
- l) Delayed ped Walk
- m) Ped Minimum Walk
- n) Ped Walk outside of Min Walk
- o) Ped Clearance / Flash Don't Walk
- p) Ped Don't Walk
- q) Waiting for negative Overlap to end
- r) Waiting for Overlap to end
- s) Undefined

3.5.2.2.5.2 Monitor Ring Termination Cause

Upon request from a management station, the ASC shall return if the active phase in the ring was terminated by force off, maximum time out or gap out.

3.5.2.2.6 Retrieve Current Channel Status Requirements

The requirements to retrieve the current status of the channels (organized as channel status groups) within the ASC follow.

3.5.2.2.6.1 Monitor Active Red Channels

Upon request from a management station, the ASC shall return for which channels currently have an active Red indication.

3.5.2.2.6.2 Monitor Active Yellow Channels

Upon request from a management station, the ASC shall return for which channels currently have an active Yellow indication.

3.5.2.2.6.3 Monitor Active Green Channels

Upon request from a management station, the ASC shall return for which channels currently have an active Green indication.

3.5.2.2.7 Retrieve Current Overlap Status Requirements

The requirements to retrieve the current status of the overlaps within the ASC follow.

3.5.2.2.7.1 Monitor Active Red Overlaps

Upon request from a management station, the ASC shall return which overlaps currently have an active Red indication.

3.5.2.2.7.2 Monitor Active Yellow Overlaps

Upon request from a management station, the ASC shall return which overlaps currently have an active Yellow indication.

3.5.2.2.7.3 Monitor Active Green Overlaps

Upon request from a management station, the ASC shall return which overlaps currently have an active Green indication.

3.5.2.2.7.4 Monitor Active Flashing Yellow Arrow Overlaps

Upon request from a management station, the ASC shall return which overlaps currently have an active Flashing Yellow Arrow indication.

3.5.2.2.7.5 Monitor Active Flashing Red Arrow Overlaps

Upon request from a management station, the ASC shall return which overlaps currently have an active Flashing Red Arrow indication.

Are there pedestrian overlaps?

3.5.2.2.8 Retrieve Current Preempt Status Requirements

The requirements to retrieve the current status of the preempts within the ASC follow.

3.5.2.2.8.1 Monitor Currently Active Preempt

Upon request from a management station, the ASC shall return the identifier of the preempts that are currently being serviced, if any.

3.5.2.2.8.2 Monitor Current Preempt Inputs

Upon request from a management station, an ASC shall return the input state for each preempt input configured in the ASC. Valid input states include:

- a) no preempt input signal detected
- b) preempt input signal is detected

3.5.2.2.8.3 Monitor Current Preempt State

Upon request from a management station, the ASC shall return the preempt status of the current active preempt. Valid preempt states are:

- a) Not Active - the preempt input is not active, and this preempt is not active
- b) Not Active With Call - the preempt input is active, but the preempt service has not initiated (Delay Interval or higher preempt service). This state is mutually exclusive to the 'Advanced Preemption' status.
- c) Advanced Preemption - the preempt service is timing the advanced preempt time. This state is mutually exclusive to the 'Not Active With Call' status.
- d) Entry Started - the preempt service is timing the entry intervals
- e) Track Service - the preempt service is timing the track clearance intervals
- f) Dwell - the preempt service is timing the dwell intervals
- g) Link Active - the preempt service is performing the linked operation
- h) Exit Strategy in Effect - the preempt service is timing the exit strategy
- i) Maximum Presence - the preempt input has exceeded the preempt's maximum presence time
- j) Other - preempt service is not specified in NTCIP 1202.

Each preempt input can be only in one state at a time. Is there a hierarchy?

3.5.2.2.8.4 Monitor Current Gate Status

Upon request from a management station, the ASC shall return whether each of the gates are **fully** lowered.

3.5.2.2.9 Retrieve Special Function Outputs Requirements

The requirements to retrieve the special functions within the ASC follow.

3.5.2.2.9.1 Determine Maximum Number of Special Functions

Upon request from a management station, the ASC shall return the maximum number of special functions, as a number from 1 to 255, which can be configured in the ASC.

3.5.2.2.9.2 Monitor Special Function Status

Upon request from a management station, the ASC shall return an indication whether a special function, regardless if it is a physical or logical function, is on or off.

3.5.2.2.9.3 Monitor Special Function Control Source

Upon request from a management station, the ASC shall return the source that activated a special function, regardless if it is a physical or logical function. Valid Values are:

- a) Remote. A management station activated the special function
- b) Timebased. The Action Scheduler activated the special function
- c) Front Panel. The special function was activated via the front panel

3.5.2.2.10 Monitor Timebase Action Status Requirements

The requirements to monitor the timebased scheduler operations within the ASC follow.

3.5.2.2.10.1 Monitor Timebase Action Status

Upon request from a management station, the ASC shall return the identifier of the scheduled function (or group of functions) that is in effect if the ASC is in timebase operation. A value of zero indicates that no timebase action is active at the requested return time.

3.5.2.2.10.2 Monitor Timebase Timing Pattern Status

Upon request from a management station, the ASC shall return the scheduled timebase pattern that is in effect if the ASC is in timebase operation. A value of zero indicates that no time base action is active at the requested return time.

3.5.2.2.11 Monitor Intra-Cabinet Communications Requirements

The requirements to monitor the intra-cabinet communications within the ASC follow.

3.5.2.2.11.1 Monitor TS2 Port 1 Status

Upon request from a management station, the ASC shall return the communications status with the device on a TS2 Port 1 address. Valid TS2 Port 1 States are:

- a) Online. Indicates that at least five of the most recent ten response transfers were received correctly.

- b) Response Fault. Indicates that more than five of the most recent ten response transfers were received incorrectly.
- c) Other. Indicates a state not specified by this standard.

3.5.2.2.11.2 Monitor TS2 Port 1 Fault Frame

Upon request from a management station, the ASC shall return the frame number that caused the most recent fault for a TS2 Port 1 address.

3.5.2.2.11.3 Monitor Serial Bus 1 Status

Upon request from a management station, the ASC shall return the communications status with the device on a Serial Bus 1 address. Valid Serial Bus 1 States are:

- a) Online. Indicates that at least five of the most recent ten response transfers were received correctly.
- b) Response Fault. Indicates that more than five of the most recent ten response transfers were received incorrectly.
- c) Other. Indicates a state not specified by the standard.

3.5.2.2.12 Monitor Peer-to-Peer Connection Requirements

The requirements to monitor the status of a peer-to-peer connection follow.

3.5.2.2.12.1 Monitor Peer-to-Peer Trigger Count

Upon request from a management station, the ASC shall return the number of times the trigger condition evaluated to 'true' since the ASC was last rebooted.

3.5.2.2.12.2 Monitor Peer-to-Peer Trigger Failure Count

Upon request from a management station, the ASC shall return the number of times the evaluation of the trigger conditions failed since the ASC was last rebooted. For example, a trigger evaluation might fail if a variable in an expression cannot be obtained.

3.5.2.2.12.3 Monitor Peer-to-Peer Action Failure Count

Upon request from a management station, the ASC shall return the number of times the action called by this conditional trigger failed since the last reboot.

Note: this requires a response from the remote device.

3.5.2.2.13 Monitor Signal Monitoring Unit Requirements

The requirements to monitor the signal monitoring unit follow.

3.5.2.2.13.1 Monitor Signal Monitoring Cabinet Flash State

Upon request from a management station, the ASC shall return the flash state of the cabinet as provided by the signal monitoring unit. This is an indication of whether the flash transfer relay has the cabinet in a flashing state.

3.5.2.2.13.2 Monitor Signal Monitoring Unit Channel Voltage

Upon request from a management station, the ASC shall return the voltage, in VAC RMS, from 0 to 254 VAC RMS, on a channel as provided by the signal monitoring unit. A value of 255 is used to indicate unknown, or no measurement.

3.5.2.2.13.3 Monitor Signal Monitoring Unit Channel Current

Upon request from a management station, the ASC shall return the current, in milliAmps, from 0 to 65000 mA, on a channel as provided by the signal monitoring unit. A value of 65535 indicates unknown or no measurement. (may be based on SMU type).

3.5.2.2.13.4 Retrieve Programmed Conflicts from the Signal Monitoring Unit

Upon request from a management station, the ASC shall return the programmed conflicting phases as programmed in the SMU. This requirement assumes that the ASC retrieves the programmed conflicting phases from the SMU in the cabinet. For some SMUs, this requires reading the state of the dip switches or the diodes on the SMU (may be based on the SMU type).

3.5.2.3 Manage Signal Operations Control Requirements

The requirements to manage the control of the signal operations within the ASC follow.

3.5.2.3.1 Control ASC Function Requirements

The requirements to activate functions within the ASC follow.

3.5.2.3.1.1 Control External Minimum Recall

Upon request from a management station, the ASC shall store if a recurring demand is to exist on all phases for minimum vehicle service.

3.5.2.3.1.2 Control Call to Nonactuated 1

Upon request from a management station, the ASC shall store if all phases programmed to respond to a Call To Nonactuated 1 input should operate in nonactuated mode.

3.5.2.3.1.3 Control Call to Nonactuated 2

Upon request from a management station, the ASC shall store if all phases programmed to respond to a Call To Nonactuated 2 input should operate in nonactuated mode.

3.5.2.3.1.4 Control Walk Rest Modifier

Upon request from a management station, the ASC shall store if any nonactuated phases remain in the timed-out Walk state (Rest in Walk) in the absence of a serviceable conflicting call.

3.5.2.3.1.5 Control Interconnect

Upon request from a management station, the ASC shall store if the interconnect inputs operate at a higher priority than the timebase control.

3.5.2.3.1.6 Control Dimming Enabled

Upon request from a management station, the ASC shall store if channel dimming operates as configured. Dimming only occurs if this value or a dimming input is enabled and simultaneously an auxiliary function is defined in the time-based scheduler.

3.5.2.3.1.7 Disable Remote Commands

Upon request from a management station, the ASC shall store if the ASC may not accept remote commands from a master or from central. This requirement allows a maintenance worker at the ASC cabinet to perform maintenance without interference from a management station.

3.5.2.3.1.8 Acknowledge Local Cycle Zero Alarm

Upon request from a management station, the ASC shall return the alarm value for passing the Local Cycle Zero point. If the alarm value is on (enabled), then upon returning the alarm value, the ASC shall reset the alarm value to off.

3.5.2.3.2 Command Timing Pattern Requirements

The requirements to select the mode of operation or a timing pattern within the ASC follow.

3.5.2.3.2.1 Command System Timing Pattern

Upon request from a management station, the ASC shall allow a management station to select the coordinated timing pattern or operational mode for the ASC. Valid patterns/modes that can be commanded are:

- a) Standby. Allows the ASC to select the pattern or mode based on the local timebase schedule or interconnect inputs.
- b) Pattern Number. Commands the ASC to a specific timing pattern. Timing patterns are identified by an identifier from 1 to 253.
- c) Free. Commands the ASC to operate in free mode without coordination.
- d) Flash. Commands the ASC to operate in automatic flash.

3.5.2.3.2.2 Command System Timing Pattern System Reference Point

Upon request from a management station, the ASC shall store the System Reference Point for the called system pattern by defining a point in the system pattern cycle in seconds, from 0 to 254 seconds. This System Reference Point is established to the next System Reference Point. If the System Reference Point is set to 255, the ASC references the system reference point to the local timebase.

3.5.2.3.3 Control Phases Requirements

The requirements to control the phases within the ASC follow.

3.5.2.3.3.1 Control Phase Omits

Upon request from a management station, the ASC shall store which phases are to be prevented from being active. The ASC removes the omit command for all phases if the ASC is placed into backup mode. If a phase is omitted remotely, the ASC resets the backup timer to zero seconds.

3.5.2.3.3.2 Control Pedestrian Phase Omits

Upon request from a management station, the ASC shall store which phases are to have their corresponding pedestrian movements prevented from being active. The ASC removes the omit command

for all pedestrian movements in the control group if the ASC is placed into backup mode. If a pedestrian movement is omitted remotely, the ASC resets the backup timer to zero seconds.

3.5.2.3.3.3 Control Phase Holds

Upon request from a management station, the ASC shall activate/deactivate a hold command for a phase, which is equivalent to energizing the Hold input (See NEMA TS-2, Section 3.5.3.11.1). The ASC removes the phase hold command for all phases if the ASC is placed into backup mode. If a phase is put into hold state remotely, the ASC resets the backup timer to zero seconds.

3.5.2.3.3.4 Control Phase Force Offs

Upon request from a management station, the ASC shall activate/deactivate a Force Off command for a phase, which is equivalent to energizing the Force Off input (See NEMA TS-2, Section 3.5.4.1.1). The ASC removes the phase force off command for all phases if the ASC is placed into backup mode. If a phase is forced off remotely, the ASC resets the backup timer to zero seconds.

3.5.2.3.3.5 Control Phase Vehicle Calls

Upon request from a management station, the ASC shall store which phases are to have vehicle calls placed on them. The ASC removes the phase vehicle call command for all phases if the ASC is placed into backup mode. If a vehicle call for a phase is placed remotely, the ASC resets the backup timer to zero seconds. This requirement is applicable to bicycle calls and transit vehicle calls also.

3.5.2.3.3.6 Control Phase Pedestrian Calls

Upon request from a management station, the ASC shall store which phases are to have pedestrian calls placed on them. The ASC removes the phase pedestrian call command for all phases if the ASC is placed into backup mode. If a pedestrian call for a phase is placed remotely, the ASC resets the backup timer to zero seconds.

3.5.2.3.4 Control Preempt Requirements

The requirements to control the preempts within the ASC follow.

3.5.2.3.4.1 Command Preempt Remote Activation

Upon request from a management station, the ASC shall manually activate a preempt. If the preemption action has already been started by a preemption input, the ASC keeps that already-started preemption action. When manually activating a preempt, the ASC remains in preemption until it completes the preemption sequence or until the management station removes the preempt.

The ASC resets the preempt control state to zero when the ASC goes into Backup Mode. If the ASC is commanded to change the preempt control state remotely, the ASC resets the backup timer to zero.

3.5.2.3.5 Control Ring Requirements

The requirements to activate the ring control functions within the ASC follow.

3.5.2.3.5.1 Control Ring Stop Time

Upon request from a management station, the ASC shall activate/deactivate the stop timing input for a ring. The ASC removes the stop timing input when the ASC goes into Backup Mode. If the ASC is commanded to change the ring control stop time settings remotely, the ASC resets the backup timer to zero seconds.

3.5.2.3.5.2 Control Ring Force Offs

Upon request from a management station, the ASC shall activate/deactivate a Force Off input for a ring. The ASC removes the ring control force off input when the ASC goes into Backup Mode. If the ASC is commanded to change the ring control force off settings remotely, the ASC resets the backup timer to zero seconds.

3.5.2.3.5.3 Control Ring Maximum Settings

Upon request from a management station, the ASC shall activate/deactivate the maximum mode for a ring. The valid maximum modes are:

- a) maxInhibit. The maximum timing settings are not used while this ring is in use.
- b) maximum1. The Maximum 1 timing is used while this ring is in use.
- c) maximum2. The Maximum 2 timing is used while this ring is in use.
- d) maximum3. The Maximum 3 timing is used while this ring is in use.

If the ASC is commanded to change the ring maximum time settings remotely, the ASC resets the backup timer to zero seconds.

Why do we need this? This is done on pattern level. Response: So it's still in effect even if I change patterns. This is temporary – such as for special events.

3.5.2.3.5.4 Control Ring Pedestrian Recycle Settings

Upon request from a management station, the ASC shall store if the pedestrian recycle setting is active for each ring. The ASC resets the ring control pedestrian recycle settings to zero, when the ASC goes into Backup Mode. If the ASC is commanded to change the ring control pedestrian recycle settings remotely, the ASC resets the backup timer to zero seconds.

3.5.2.3.5.5 Control Ring Red Rest Settings

Upon request from a management station, the ASC shall store if the Red rest setting is active for each ring. The ASC resets the ring control Red rest settings to zero, when the ASC goes into Backup Mode. If the ASC is commanded to change the ring control Red rest settings remotely, the ASC resets the backup timer to zero seconds.

3.5.2.3.5.6 Control Ring Red Clearance Omit Settings

Upon request from a management station, the ASC shall store if the Red clearance setting is omitted for each ring. The ASC resets the ring control Red clearance omit settings to zero, when the ASC goes into Backup Mode. If the ASC is commanded to change the ring control Red clearance omit settings remotely, the ASC resets the backup timer to zero seconds.

3.5.2.3.6 Special Functions Control Requirements

The requirements to control the special functions within the ASC follow.

3.5.2.3.6.1 Activate Special Function

Upon request from a management station, the ASC shall store if the special function, regardless if it is a physical or logical function, is turned on or off. The ASC sets this value to zero, when the ASC is in backup mode.

3.5.2.3.6.2 Release Special Function Control

Upon request from a management station, the ASC shall release the control of the special function, regardless of the current control source, and revert control back to the ASC.

3.5.2.3.7 Control Frame 40 Requirements

The requirements for active action plans within the ASC follow.

3.5.2.3.7.1 Control TS2 Port 1 Frame 40 Messages

Upon request from a management station, the ASC shall enable or disable the Frame 40 messages for each Port 1 address. Frame 40 is used to poll the secondary stations for a secondary-to-secondary message exchange. The ASC only transmits Command 40 series frames to those devices that are enabled, as determined by this value.

3.5.2.3.8 Activate Action Plan

Upon request from a management station, the ASC shall activate a configured action plan. This requirement allows a management station to activate or override a timebased action plan entry, even if the timing pattern the action plan is associated with is not in effect.

3.5.2.3.9 Remote Manual Control Requirements

The requirements to remotely advance the ASC to the next interval follow.

3.5.2.3.9.1 Enable Remote Manual Control

Upon request from a management station, the ASC shall enable or disable remote manual control mode. While in remote manual control mode, the ASC advances to the next interval only upon receiving an advance command from a management station.

3.5.2.3.9.2 Remote Manual Control Advance Command

Upon request from a management station, the ASC shall allow a management station to command the signal controller to advance to the next interval. Under remote manual control mode, the ASC behaves as if the manual control input was active. The ASC will not time phases, such as when using a coordinated timing pattern, but instead will advance to the next interval when remotely commanded to by a management station.

3.5.2.3.9.3 Configure Manual Control Timeout

Upon request from a management station, the ASC shall store a timeout value, from 1 to 255 seconds, as a failsafe in case of a loss of communications. When the ASC is in remote manual control mode, the remote manual control timer will decrement once per second until it reaches zero, at which time the ASC will disable remote manual control and revert back to normal signal operation. This forces a management station to continually reset the remote manual control timer to maintain remote manual control.

3.5.3 Detector Management Requirements

The requirements for managing the detectors of an ASC follow.

3.5.3.1 Manage Detector Configuration Requirements

The requirements to manage the detector configurations of an ASC are defined in the following paragraphs.

Requirements to configure a detector to collect detector data (e.g., volume, occupancy, speed over a period of time) can be found in NTCIP 1209.

3.5.3.1.1 Configure Detectors Requirements

To manage the traffic-actuated operations of an ASC controller, the ASC shall allow a management system to configure vehicle detectors, including bicycle detectors and transit vehicle detectors. Each detector may be a physical detector (such as a loop detector) or a virtual detector (e.g., via video processing or basic safety messages). The requirements to configure a vehicle detector of an ASC follow.

3.5.3.1.1.1 Configure Vehicle Travel Mode

Upon request from a management station, the ASC shall store the travel mode identified for the detector. The travel mode shall be one of general (not otherwise assigned), transit or bicycle. **Pedestrian detectors are managed separately.**

3.5.3.1.1.2 Configure Vehicle Detector Yellow Lock Call Enabled

Upon request from a management station, the ASC shall store if a vehicle detector is instructed to lock a call to the assigned phase if an actuation occurs while the phase is not timing the Green interval. If the Yellow Lock Call and Red Lock Call are both enabled for a given phase, the ASC shall keep the yellow lock call enabled.

3.5.3.1.1.3 Configure Vehicle Detector Red Lock Call Enabled

Upon request from a management station, the ASC shall store if a vehicle detector is instructed to lock a call to the assigned phase if an actuation occurs while the phase is not timing Green or Yellow intervals. If the Yellow Lock Call and Red Lock Call are both enabled for a given phase, the ASC shall disable the red lock call.

mutually exclusive operations

3.5.3.1.1.4 Configure Vehicle Detector Passage Enabled

Upon request from a management station, the ASC shall store if the associated phase passage timer remains reset for the duration of a vehicle detector actuation if the Phase is in the Green interval.

3.5.3.1.1.5 Configure Vehicle Detector Added Initial Time Enabled

Upon request from a management station, the ASC shall store if detector actuation counts for a vehicle detector are accumulated for use in the added initial calculations. If enabled, counts are accumulated starting at the beginning of the Yellow interval and terminating at the beginning of the Green interval.

3.5.3.1.1.6 Configure Vehicle Detector Queue Enabled

Upon request from a management station, the ASC shall store if the Green interval of the assigned phase for a vehicle detector is extended upon actuation until either a gap occurs or the Green has been active longer than the Vehicle Detector Queue Limit Time.

3.5.3.1.1.7 Configure Vehicle Detector Call Enabled

Upon request from a management station, the ASC shall store if a call is placed for vehicle service upon actuation of a vehicle detector while the phase is not timing the Green interval.

3.5.3.1.1.8 Configure Vehicle Detector Call Phase

Upon request from a management station, the ASC shall store the assigned phase associated with a vehicle detector. If no phase is assigned, the ASC disables the ability of the detector to call a phase.

3.5.3.1.1.9 Configure Vehicle Detector Switch Phase

Upon request from a management station, the ASC shall store the programmed (switch) phase to which actuation of a vehicle detector is switched when the current (extend) phase is Yellow or Red and the programmed (switch) phase is Green. Detector switching allows the detector to call and extend the current phase and send calls to the switch phase once the current phase ends.

3.5.3.1.1.10 Configure Vehicle Detector Delay Time

Upon request from a management station, the ASC shall store the time, in tenths of a second, from 0 to 255.0 seconds, that an actuation for a vehicle detector is delayed when the phase is not Green.

3.5.3.1.1.11 Configure Vehicle Detector Extend Time

Upon request from a management station, the ASC shall store the time, in tenths of a second, from 0 to 25.5 seconds, that an actuation for a vehicle detector is extended from the point of termination, when the phase is Green.

3.5.3.1.1.12 Configure Vehicle Detector Queue Limit Time

Upon request from a management station, the ASC shall store the length of time in seconds, from 0 to 255 seconds, that an actuation from a vehicle queue detector may continue into the Green phase. This time commences when the phase becomes Green and when the time expires, the ASC ignores any associated actuations / detector inputs. The ASC might shorten this time due to other overriding parameters such as Maximum Green time or Force Off commands.

3.5.3.1.1.13 Configure Vehicle Detector No Activity Fault Time

Upon request from a management station, the ASC shall store the time period in minutes, from 0 to 255 minutes, before the ASC declares the absence of any actuations for a vehicle detector to be a fault and the vehicle detector is classified as failed. The ASC disables the diagnostics for this detector if the No Activity Time value for this vehicle detector is set to zero.

3.5.3.1.1.14 Configure Vehicle Detector Maximum Presence Fault Time

Upon request from a management station, the ASC shall store the time period in minutes, from 0 to 255 minutes, before the ASC declares the presence of a continuous actuation of a vehicle detector to be a fault and the vehicle detector is classified as failed. The ASC disables the diagnostics for this detector if the Maximum Presence Time value for this vehicle detector is set to zero.

3.5.3.1.1.15 Configure Vehicle Detector Erratic Counts

Upon request from a management station, the ASC shall store the number of actuations for a vehicle detector, from 0 to 255 counts per minute, above which the ASC declares the vehicle detector to be a fault and the vehicle detector is classified as failed. The ASC disables the diagnostics for this detector if the Erratic Count value for this vehicle detector is set to zero.

3.5.3.1.1.16 Configure Vehicle Detector Fail Time

Upon request from a management station, the ASC shall store the amount of time, in seconds, that the ASC holds a call for the associated phase during all non-Green intervals for a failed vehicle detector. The

ASC places a constant call on the phase (maximum recall) if the vehicle detector fail time is set to the maximum of 255 seconds. The ASC does not place a call on this detector if the Fail Time value for this vehicle detector is set to zero.

3.5.3.1.2 Configure Pedestrian Detectors Requirements

MUTCD (FHWA MUTCD 2023 Edition, Section 4I.05) defines, "Pedestrian detectors may be pushbuttons or passive detection devices. Passive detection devices register the presence of a pedestrian in a position indicative of a desire to cross, without requiring the pedestrian to push a button. Some passive detection devices are capable of tracking the progress of a pedestrian as the pedestrian crosses the roadway for the purpose of extending or shortening the duration of certain pedestrian timing intervals".

The requirements to manage the pedestrian detector configurations of an ASC follow.

3.5.3.1.2.1 Configure Pedestrian Detector Call Phase

Upon request from a management station, the ASC shall store the assigned phase associated with a pedestrian detector. If no phase is assigned, the ASC disables the ability of the pedestrian detector to call a phase.

3.5.3.1.2.2 Configure Pedestrian Detector No Activity Fault Time

Upon request from a management station, the ASC shall store the time period in minutes, from 0 to 255 minutes, when the ASC declares the absence of any actuations for a pedestrian detector to be a fault, and the pedestrian detector is classified as failed. The ASC disables the diagnostics for this detector, if the No Activity Time for this pedestrian detector is set to zero.

3.5.3.1.2.3 Configure Pedestrian Detector Maximum Presence Fault Time

Upon request from a management station, the ASC shall store the time period in minutes, from 0 to 255 minutes, when the ASC will declare the presence of a continuous actuation of a pedestrian detector to be a fault, and the pedestrian detector is classified as failed. The ASC disables the diagnostics for this detector if the Maximum Presence Time for this pedestrian detector is set to zero.

3.5.3.1.2.4 Configure Pedestrian Detector Erratic Counts

Upon request from a management station, the ASC shall store the number of actuations for a pedestrian detector, from 0 to 255 counts per minute, above which the ASC declares the pedestrian detector to be a fault and the pedestrian detector is classified as failed. The ASC disables the diagnostics for this detector, if the Erratic Count value for this pedestrian detector is set to zero.

3.5.3.1.2.5 Configure Pedestrian Detector Non-Lock Calls

Upon request from a management station, the ASC shall store if a pedestrian detector is used to place non-locked calls for pedestrian timings.

3.5.3.1.2.6 Configure Pedestrian Detector Alternate Pedestrian Timing

Upon request from a management station, the ASC shall store if a pedestrian detector is used to place calls for alternate pedestrian timing.

3.5.3.1.2.7 Configure Pedestrian Detector Type

Upon request from a management station, the ASC shall store if a pedestrian detector is used to detect the presence of a pedestrian in the pedestrian crosswalk instead of detecting a pedestrian call for service.

3.5.3.1.3 Retrieve Detector Configuration Requirements

The requirements to retrieve the detector configuration settings including vehicle and pedestrian detectors from the ASC follow.

3.5.3.1.3.1 Retrieve Vehicle Detectors Requirements

The requirements to retrieve the vehicle detector configurations of an ASC follow.

3.5.3.1.3.1.1 Determine Maximum Number of Vehicle Detectors

Upon request from a management station, the ASC shall return the maximum number of vehicle detectors that can be configured within the ASC.

3.5.3.1.3.1.2 Retrieve Vehicle Detector Configurations

Upon request from a management station, the ASC shall return the configuration parameters for all vehicle detectors in service.

3.5.3.1.3.2 Retrieve Pedestrian Detectors Requirements

The requirements to retrieve the vehicle detector configurations of an ASC follow.

3.5.3.1.3.2.1 Determine Maximum Number of Pedestrian Detectors

Upon request from a management station, the ASC shall return the maximum number of pedestrian detectors that can be configured within the ASC.

3.5.3.1.3.2.2 Retrieve Pedestrian Detector Configurations

Upon request from a management station, the ASC shall return the configuration parameters for all pedestrian in service.

3.5.3.2 Retrieve Detector Status Requirements

The requirements to monitor the status of the detectors connected to an ASC controller follow.

3.5.3.2.1 Determine Detector Data Active Detectors

Upon request from a management station, the ASC shall return the number of vehicle detectors configured for this ASC.

3.5.3.2.2 Monitor Active Vehicle Detector Status

Upon request from a management station, the ASC shall return which vehicle detectors are currently actuated (vehicle presence detected).

3.5.3.2.3 Determine Pedestrian Detector Data Active Detectors

Upon request from a management station, the ASC shall return the number the pedestrian detectors configured for the ASC.

3.5.3.2.4 Monitor Active Pedestrian Detector Status

Upon request from a management station, the ASC shall return which pedestrian detectors are currently actuated (pedestrian presence detected or actuated by a pedestrian).

3.5.3.3 Retrieve Detector Health Requirements

The requirements to monitor the health status of the detectors connected to an ASC controller follow.

3.5.3.3.1 Retrieve Vehicle Detector Health Requirements

The requirements to monitor the health status of vehicle detectors connected to an ASC controller follow.

3.5.3.3.1.1 Monitor Vehicle Detector Alarm Status

Upon request from a management station, the ASC shall return which vehicle detectors currently have an active alarm. The ASC clears any alarm that is not currently active.

3.5.3.3.1.2 Monitor Vehicle Detector No Activity Fault

Upon request from a management station, the ASC shall return if a vehicle detector has been flagged as non-operational / failed due to the absence of any actuations for a user-defined time period (no activity time).

3.5.3.3.1.3 Monitor Vehicle Detector Maximum Presence Fault

Upon request from a management station, the ASC shall return if a vehicle detector has been flagged as non-operational / failed due to the continuous actuations for a user-defined time period (maximum presence time).

3.5.3.3.1.4 Monitor Vehicle Detector Erratic Output Fault

Upon request from a management station, the ASC shall return if a vehicle detector has been flagged as non-operational / failed due to a higher number of actuations per minute than the user-defined threshold (erratic counts).

3.5.3.3.1.5 Monitor Vehicle Detector Communications Fault

Upon request from a management station, the ASC shall return if communications with a vehicle detector have failed.

3.5.3.3.1.6 Monitor Vehicle Detector Configuration Fault

Upon request from a management station, the ASC shall return if a vehicle detector is assigned but is not supported.

3.5.3.3.2 Retrieve Vehicle Loop Detector Health Requirements

The requirements to monitor the health status of vehicle loop detectors connected to an ASC follow.

3.5.3.3.2.1 Monitor Loop Vehicle Detector Watchdog Failure

Upon request from a management station, the ASC shall return if a vehicle loop detector has been flagged as non-operational / failed due to a watchdog failure.

3.5.3.3.2.2 Monitor Loop Vehicle Detector Open Loop Failure

Upon request from a management station, the ASC shall return if a vehicle loop detector has been flagged as non-operational / failed due to an open loop (broken wire).

3.5.3.3.2.3 Monitor Loop Vehicle Detector Shorted Loop Fault

Upon request from a management station, the ASC shall return if a vehicle loop detector has been flagged as non-operational / failed due to a shorted loop wire.

3.5.3.3.2.4 Monitor Loop Vehicle Detector Excessive Change Fault

Upon request from a management station, the ASC shall return if a vehicle loop detector has been flagged as non-operational / failed due to an inductance change that exceed expected values.

3.5.3.3.3 Retrieve Pedestrian Detector Health Requirements

The requirements to monitor the health status of pedestrian detectors connected to an ASC follow.

3.5.3.3.3.1 Monitor Pedestrian Detector Alarm Status

Upon request from a management station, the ASC shall return which pedestrian detectors have an active alarm. The ASC clears any alarm that is not currently active.

3.5.3.3.3.2 Monitor Pedestrian Detector No Activity Fault

Upon request from a management station, the ASC shall return if a pedestrian detector has been flagged as non-operational / failed due to the absence of any actuations for a user-defined time period (no activity time).

3.5.3.3.3.3 Monitor Pedestrian Detector Maximum Presence Fault

Upon request from a management station, the ASC shall return if a pedestrian detector has been flagged as non-operational / failed due to the continuous actuations for a user-defined time period (maximum presence time).

3.5.3.3.3.4 Monitor Pedestrian Detector Erratic Output Fault

Upon request from a management station, the ASC shall return if a pedestrian detector has been flagged as non-operational / failed due to a higher number of actuations per minute than the user-defined threshold (erratic counts).

3.5.3.3.3.5 Monitor Pedestrian Detector Communications Fault

Upon request from a management station, the ASC shall return if communications with a pedestrian detector have failed.

3.5.3.3.3.6 Monitor Pedestrian Detector Configuration Fault

Upon request from a management station, the ASC shall return if a pedestrian detector is assigned but is not supported.

3.5.3.3.3.7 Monitor Pedestrian Services

Upon request from a management station, the ASC shall return the number of pedestrian services (the number of times the pedestrian transitioned from don't walk to walk) during the defined sample period.

3.5.3.4 Control Detector Requirements

The requirements to control detectors connected to an ASC follow.

3.5.3.4.1 Control Vehicle Detector Reset

Upon request from a management station, the ASC shall reset a vehicle detector. The ASC automatically returns a detector reset to a non-reset state after the ASC has executed the reset command.

3.5.3.4.2 Control Pedestrian Detector Reset

Upon request from a management station, the ASC shall reset a pedestrian detector. The ASC automatically returns a detector reset to a non-reset state after the ASC has executed the reset command.

3.5.3.4.3 Control Vehicle Detector Actuation

Upon request from a management station, the ASC shall place an actuation on a vehicle detector.

3.5.3.4.4 Control Pedestrian Detector Actuation

Upon request from a management station, the ASC shall place an actuation on a pedestrian detector.

3.5.3.5 Manage Detector Data Collection Requirements

The requirements to manage the data obtainable from the vehicle detectors connected to an ASC controller will be found in NTCIP 1209 - the specific requirements will be found under User Need 2.5.3.5, Manage Detector Data in Table 5 Protocol Requirements List (PRL).

3.5.4 Connected Vehicles Interface Management

The requirements for managing the interfaces for an ASC in a connected vehicle environment are categorized as follows:

- a) Interface - Management Station - ASC (ASC Process)
- b) Interface - ASC (ASC Process) - CV Application Process

The requirements for managing the connected vehicles interface of an ASC follow.

3.5.4.1 Manage Management Station – ASC Interface Requirements

The management station for these requirements is NOT an RSU, it represents a computing device at a traffic management center or could be a field maintenance laptop. The requirements to manage the data exchanges between a management station and the ASC are:

- a) Manage RSU Interface Requirements
- b) Manage RSU Interface Watchdog Requirements
- c) Manage Signal Phase and Timing Data Requirements
- d) Manage Assured Green Period Requirements

The requirements for a management station to manage the ASC in a connected vehicle environment follow.

3.5.4.1.1 Manage CV Application Process Interface Requirements

The requirements to manage the interface between the ASC and an RSU (CV Application Process) follow.

3.5.4.1.1.1 Configure RSU Interface

Upon request from a management station, the ASC shall store which communications port is used to exchange data with an RSU.

3.5.4.1.1.2 Configure Logical RSU Ports

Upon request from a management station, the ASC shall store the name and network address of each RSU that the ASC will exchange data with. An ASC may communicate with up to 16 RSUs as part of the connected vehicle environment.

3.5.4.1.1.3 Configure RSU Interface Polling Period

Upon request from a management station, the ASC shall store the period, in milliseconds, that the ASC exchanges data with an RSU for connected vehicle data.

3.5.4.1.2 Manage CV Application Process Interface Watchdog Requirements

The requirements to manage the watchdog timer for the ASC's interface with an RSU follow.

3.5.4.1.2.1 Configure RSU Interface Watchdog

Upon request from a management station, the ASC shall store the maximum time duration, in milliseconds, for an RSU watchdog timer in the ASC. The RSU watchdog timer is used to track activity across a RSU interface. If no activity is detected across the RSU interface for a period longer than the maximum time duration a RSU watchdog not activity fault is reported. The RSU watchdog timer is a value from 1 to 65535 milliseconds and includes a value to disable the watchdog timer.

3.5.4.1.2.2 Monitor RSU Interface Watchdog Timer

Upon request from a management station, the ASC shall return the RSU watchdog time, from 0 to 65535 milliseconds, for a specific logical RSU port as provided in the request. The RSU watchdog time represents the amount of time that has elapsed since activity was last detected across the specified logical RSU port interface.

3.5.4.1.3 Manage Signal Phase and Timing Requirements

Some of the key applications that have been developed for the connected vehicle environment are related to intersection safety. For signalized intersections, this involves an RSU broadcasting SPaT (Signal Phase and Timing) messages, as defined by SAE J2735, to connected vehicles in the vicinity. The source of the SPaT data broadcasted by an RSU comes from the ASC, so the ASC has to exchange this data with the CV Application Process in an RSU. However, a management station, such as one in a traffic management center, needs to monitor what data is being broadcasted to connected vehicles. The requirements that allow a management station to configure and retrieve signal phase and timing data from an ASC follow.

3.5.4.1.3.1 Enable Signal Phase and Timing Data

Upon request from a management station, the ASC shall store if the controller is to generate signal phase and timing data for the intersection(s).

3.5.4.1.3.2 Retrieve Signal Phase and Timing Generation Time

Upon request from a management station, the ASC shall return the time when the signal phase and timing data was generated by the ASC. This timestamp is represented in hours, minutes, seconds and milliseconds of the time of day. This requirement is for testing purposes only. This requirement allows the operator at a TMC to view when the controller generates the SPaT data. Note it is not used by the RSU to generate the SAE J2735 SPaT message, though it may be a need in the future. The timestamp in the SAE J2735 SPaT message is the time the message is generated and signed.

3.5.4.1.3.3 Exchange Movement Status Requirements

The SPaT message that is broadcasted by an RSU to connected vehicles includes information about what vehicle (and pedestrian) movements are permitted at a signalized intersection. To provide this information the RSU needs movement data from the ASC. These requirements allow a management station to monitor the movement data that an ASC is exchanging with the CV Application Process. The requirements to retrieve the movement data that an ASC is exchanging with a CV Application Process are defined as follows.

3.5.4.1.3.3.1 Retrieve Movement Timing Requirements

The requirements to provide the timing of a movement at the intersection are defined as follows.

NOTE: it is required that an ASC system time be synchronized with an accurate and reliable UTC time source before providing these time points.

3.5.4.1.3.3.1.1 Monitor Movement Minimum End Time

Upon request from a management station, the ASC shall return the time point of earliest end time for the current movement state (e.g., at the end of a permissive green or at the end of a permissive yellow) of a movement at an intersection. If the duration of the current state of a movement is fixed, this value indicates the end time (and is equal to the Movement Maximum End Time). This value can be viewed as the earliest possible time point at which the current interval could change, except when unpredictable events relating to a preemption or priority call come into play and disrupt a currently active timing plan. The time point is measured in tenths of a second in the current or next hour.

3.5.4.1.3.3.1.2 Monitor Movement Maximum End Time

Upon request from a management station, the ASC shall return the latest possible end time point of the current movement state (e.g., at the end of a protected green or end of a steady red) of a movement at an intersection. This value can be viewed as the latest possible time point at which the current interval could change, except when unpredictable events relating to a preemption or priority call come into play and disrupt a currently active timing plan. The time point is measured in tenths of a second in the current or next hour. If the duration of the current state of a movement is fixed, this value indicates the end time (and is equal to the Movement Minimum End Time).

3.5.4.1.3.3.1.3 Monitor Movement Likely End Time

Upon request from a management station, the ASC shall return the time point when the current movement state of a movement will most likely end (e.g., at the end of a protected green or end of a steady red) at an intersection. The likely end time point may be predicted based on data available to the ASC. The time point is measured in tenths of a second in the current or next hour. A value of undefined is returned when the time point cannot be estimated with a high level of confidence.

3.5.4.1.3.3.1.4 Monitor Movement Likely End Time Confidence

Upon request from a management station, the ASC shall return the statistical confidence that the reported likely end time for the current movement state (e.g., at the end of a protected green or end of a permissive clearance time) of a movement at an intersection is accurate. The confidence value is measured as a probability class, as defined by DE_TimeIntervalConfidence in SAE J2735.

3.5.4.1.3.3.1.5 Monitor Movement Next Occurrence

Upon request from a management station, the ASC shall return the estimated time point when a movement at an intersection is next allowed to proceed (i.e., the movement phase state will be permissive-Movement-Allowed or protected-Movement-Allowed). The time point is measured in tenths of a second in the current or next hour. This value can be viewed as the estimated time point at which the movement is next allowed to proceed, except when unpredictable events relating to a preemption or priority call come into play and disrupt a currently active timing plan. A value of undefined is returned when the time point cannot be estimated with a high level of confidence. This requirement is used to support ECO-driving applications.

3.5.4.1.3.3.1.6 Monitor Next Movement Minimum End Time

Upon request from a management station, the ASC shall return the time point of the earliest possible end of the movement state immediately after the current movement state at the intersection. If the interval duration of the next movement state is fixed, this value indicates the end time point and is equal to the Next Movement Maximum End Time. This value can be viewed as the earliest possible time point at which the next interval could end, except when unpredictable events relating to a preemption or priority call come into play and disrupt a currently active timing plan. The time point is measured in tenths of a second in the current or next hour. If the next movement state is unknown, the time point of the earliest possible end time is also unknown.

3.5.4.1.3.3.1.7 Monitor Next Movement Maximum End Time

Upon request from a management station, the ASC shall return the time point of the latest possible end of the movement state immediately after the current movement state at the intersection. This value can be viewed as the latest possible time point at which the next movement state could end, except when unpredictable events relating to a preemption or priority call come into play and disrupt a currently active timing plan. The time point is measured in tenths of a second in the current or next hour. If the next movement state is unknown, the time point of the latest possible end time is also unknown. If the interval duration of the next movement state is fixed, this value indicates the end time point and is equal to the Next Movement Maximum End Time.

3.5.4.1.3.3.1.8 Monitor Next Movement Start Time

Upon request from a management station, the ASC return the time point, in tenths of a second in the current or next hour, of the next (future) movement state to follow the current movement state for a signal group. If the start time is unknown, a value of unknown is used. If the next movement state is unknown, the start time will also be unknown. If the next movement state is known, the start time is equal to the movement minimum end time of the current interval.

Note: Start time is always a future time (See CTI 4501, Section 3.3.3.3.5.6 and 3.3.3.3.5.7). Thus, the start time of the current interval is NOT provided.

3.5.4.1.3.3.1.9 Determine Maximum Number of Movement Events

Upon request from a management station, the ASC return the number of movement events for each signal group supported. CTI 4501 requires that at least two movement events be supported – the first movement event represents the current interval and the second movement event represents the next

interval (after the current interval). The SAE J2735 SPaT message supports up to 16 movement events for each signal group.

3.5.4.1.3.3.2 Configure Movement Assistance Requirements

The SPaT message in SAE J2735 can also provide potential pedestrian or bicyclist conflicts and queuing information to travelers. The requirements to configure detectors to provide this information to travelers wishing to traverse through the intersection are defined as follows.

3.5.4.1.3.3.2.1 Configure Queue Detectors for Movement Assistance

Upon request from a management station, the ASC shall store the identifiers of the vehicle detectors that provide queue information for a specific movement through the intersection. This queue information, measured in meters, is provided so connected vehicles are aware of how many vehicles are queued, if any, for a specific movement through the intersection.

3.5.4.1.3.3.2.2 Configure Pedestrian Detectors for Movement Assistance

Upon request from a management station, the ASC shall store the identifiers of the pedestrian (presence) detectors indicating the potential presence of pedestrians that conflict with a specific vehicle movement through the intersection. This information is provided so connected vehicles are aware of the potential presence of a pedestrian may conflict with its movement through the intersection.

3.5.4.1.3.3.2.3 Configure Bicycle Detectors for Movement Assistance

Upon request from a management station, the ASC shall store the identifiers of the detectors that determine the presence of bicyclists that conflict with a specific vehicle movement through the intersection. This information is provided so connected vehicles are aware of the potential presence of a bicyclist may conflict with its movement through the intersection.

3.5.4.1.3.3.3 Retrieve Movement Assistance Requirements

The requirements to provide potential pedestrian or bicyclist conflicts and queuing information to assist connected vehicles traversing through the intersection are defined as follows.

3.5.4.1.3.3.3.1 Monitor Lane Connection Queue Length

Upon request from a management station, the ASC shall return the distance, in meters, from the stop line of the approach movement to the back edge of the last vehicle in the queue, as measured along the center line of the lane for a specific movement maneuver through the intersection. Valid values are 0 to 10000 meters, where 0 indicates no queue or the queue distance is unknown, and 10000 represents all distance \geq 10000 meters. The detectors that provide this queue information is configured in Section 3.5.4.1.3.3.2.1.

3.5.4.1.3.3.3.2 Monitor Lane Connection Traveler Detection

Upon request from a management station, the ASC shall return if any conflicting pedestrians or bicycles are detected for a specific movement maneuver through the intersection. This value is either on or off, with off indicating a high certainty that there is no pedestrian or bicycle present. The presence inputs that indicate if a conflicting pedestrian or bicyclist may be present is configured in Sections 3.5.4.1.3.3.2.2 and 3.5.4.1.3.3.2.3.

3.5.4.1.3.3.4 Manage Advisory Speed Requirements

The SPaT message in SAE J2735 can also provide speed advisories for specific movements and specific vehicle types. The requirements to provide advisory speed information for a movement through the intersection are defined as follows.

3.5.4.1.3.3.4.1 Configure Advisory Speed Type

Upon request from a management station, the ASC shall store the type of speed advisory for a specific movement traversing the intersection. Valid types of speed advisories are defined by DE_AdvisorySpeedType in SAE J2735. Speed advisories may also be configured for specific vehicle types as defined in the MAP message for the intersection.

3.5.4.1.3.3.4.2 Configure Advisory Speed

Upon request from a management station, the ASC shall store the advisory speed, in tenths of a meter per second, provided for a specific movement traversing the intersection. Speed advisories may be configured for specific advisory speed types (See 3.5.4.1.3.3.4.1) or vehicle types as defined in the MAP message for the intersection.

3.5.4.1.3.3.4.3 Configure Advisory Speed Zone

Upon request from a management station, the ASC shall store the distance, in meters, upstream from the stop bar that a speed advisory is recommended for a movement traversing the intersection. A value of 10000 indicates that the distance is 10,000 meters or greater. A value of 0 represents unknown.

3.5.4.1.3.3.4.4 Configure Advisory Speed Vehicle Type

Upon request from a management station, the ASC shall store the vehicle type that a speed advisory is recommended for a specific movement traversing the intersection. The vehicle type(s) is identified in the associated MAP message for the intersection. If no vehicle type is identified, then the advisory speed applies to all vehicles.

3.5.4.1.3.3.5 Monitor Movement State

Upon request from a management station, the ASC shall return the current movement phase state of a movement at the intersection. The valid states are defined by DE_MovementPhaseState in SAE J2735. If the movement state is not known with a high level of confidence, a value of unavailable is used.

3.5.4.1.3.3.6 Monitor Next Movement State

Upon request from a management station, the ASC shall return the movement state immediately after the current movement state of a movement at the intersection. The valid states are defined by DE_MovementPhaseState in SAE J2735. If the next movement state is not known with a high level of confidence, a value of unavailable is used.

3.5.4.1.3.3.7 Monitor Movement Status

Upon request from a management station, the ASC shall return the movement data containing what vehicle (or pedestrian) movements are permitted and when at an intersection in a compressed manner. The connected vehicle environment is expected to have limitations in the data rates and data capacity. This requirement allows the ASC to group sets of data so that the data can be transmitted more efficiently.

3.5.4.1.3.4 Manage Enabled Lane Requirements

The SPaT message in SAE J2735 can also indicate to travelers traversing across the intersection which revocable lanes at the intersection are currently active (enabled). Each lane defined for a roadway geometry plan can be defined as a revocable lane—that is, the lane is not always active for a specific use.

For example, a shoulder lane may be used by vehicles during rush hours and closed to vehicle traffic during all other times. In the roadway geometry (MAP) plan for the intersection, that shoulder lane can be defined as a vehicle lane and as revocable. During rush hours, the SPAT message would then indicate that the shoulder lane is active (Enabled) by including the lane identifier (of the shoulder lane). During non-rush hours, the SPAT message would not include the lane identifier of the shoulder lane, indicating that the shoulder lane is not active (enabled).

The requirements to configure and command enabled (revocable) lanes are defined as follows.

3.5.4.1.3.4.1 Configure Concurrent Enabled Lanes

Upon request from a management station, the ASC shall store what revocable lanes are allowed to be active (enabled) concurrently. This requirement allows the management station to set which revocable lane(s) may be active (enabled) at the same time, thereby preventing the enabling of conflicting revocable lanes.

3.5.4.1.3.4.2 Configure Enabled Lanes by Time of Day

Upon request from a management station, the ASC shall store if a revocable lane is active (enabled) or inactive based on a time base schedule. This requirement allows a management station to set a group of enabled lanes based on a schedule.

3.5.4.1.3.4.3 Determine Lanes Enabled

Upon request from a management station, the ASC shall return the revocable lanes that are currently enabled (active).

3.5.4.1.3.4.4 Command Enabled Lanes

Upon request from a management station, the ASC shall store if a set of revocable lanes is active (enabled) or inactive. This requirement allows a management station to remotely command if the signal phase and timing data provided to a CV Application Process to indicate which revocable lane(s) are enabled or not. The set of revocable lanes is defined in Section 3.5.4.1.3.4.1, Configure Concurrent Enabled Lanes. This command may override the set of enabled lanes in the schedule.

3.5.4.1.3.5 Enable Signal Phase and Timing Data Exchange

Upon request from a management station, the ASC shall store if the controller unit can exchange signal phase and timing data for the intersection(s) with an RSU port. An ASC may provide SPAT data to more than one RSU (or CV Application Process). This requirement allows a management station to control which RSU port(s) can the ASC share SPAT data with.

3.5.4.1.3.6 Configure Road Authority Identifier

Upon request from a management station, the ASC shall store the unique identifier of the agency that operates and/or maintains the intersection or the ASC. The unique identifier is an object identifier as defined by DF_RoadAuthorityID in SAE J2735. In the US, this object identifier allows use consisting of the Geographic Names Information System (GNIS) codes maintained by the US Geological Survey (USGS).

3.5.4.1.3.7 Retrieve Signal Phase and Timing Intersection Status Requirements

Upon request from a management station, the ASC shall return the status of the ASC as part of the signal phase and timing data broadcasted to connected devices. The intersection status values are defined by DE_IntersectionStatusObject in SAE J2735.

3.5.4.1.3.7.1 Monitor Manual Control Indication

Upon request from a management station, the ASC shall return if the intersection is operating under manual control. Manual Control indicates to the receiver of this information that the controller is "not in control", thus the controller generally does not know when the movement phase state will change. The ASC is under manual control when it receives a Manual Control Enabled (MCE) command or Manual Advance input (e.g., from a police pickle). Whether the ASC is under manual control is updated accordingly to be consistent with the current set of possible dwell/advance options. The Minimum End Time and Maximum End Time are adjusted accordingly.

3.5.4.1.3.7.2 Monitor Stop Indication

Upon request from a management station, the ASC shall return if the intersection is operating under stop time. Stop Time indicates to the receiver of this information that all counting/timing by the controller has stopped, thus most TimeChangeDetails are unknown. The ASC is under stop time when it receives a stop time input. The active (frozen) controller state on the affected (stopped) ring remains the basis to determine the MovementPhaseState for each movement and the TimeChangeDetails. When in stop time, the stop time duration is unknown, however, the TimeChangeDetails will remain consistent to the current phase timers. If the form of stop time input allows continuation of countdown timers for clearance intervals or other timers, the TimeChangeDetails are adjusted accordingly.

3.5.4.1.3.7.3 Monitor Failure Flash Indication

Upon request from a management station, the ASC shall return if the intersection is in a failure flash condition. Stop Time indicates to the receiver of this information that all counting/timing by the controller has stopped, thus most TimeChangeDetails are unknown. A failure flash condition is any type of flash that must be terminated by a source external to the controller. There are three types of failure flash.

- "Monitor Flash" is a Flash controlled by the monitor in the following two scenarios:
 - When resuming operation after a power loss or interruption, the monitor keeps the Flash Bus energized for a minimum of 6 seconds before energizing the Signal Bus and transferring control to the controller.
 - When a fault is detected by the monitor, it energizes the Flash Bus until either the fault is cleared by pressing the Reset button on the monitor (latching fault) or, with certain types of faults, when the condition that caused the fault is no longer present (non-latching fault).
- "Fault Monitor Flash" occurs when the controller detects an anomaly in the TSC Infrastructure, such as a mismatch between its copy of the permissive channels and the monitor's copy of the permissive channels.
- "Local Flash" is a flash controlled by human-operated switches in the cabinet, typically labeled "AUTO/FLASH", that is used by technicians to flash the signals when performing maintenance on the controller (Tech Flash) or by police during unusual traffic conditions or situations (Police Flash).

The end of Failure Flash is indeterminate because the ASC does not know when the monitor is going to be reset or when the flash switch is going to be moved from "FLASH" to "AUTO". Therefore, the TimeChangeDetails during Failure Flash cannot be supplied.

Note: It is more important for SPaT to match the roadway signalization rather than internal controller logic. Some cabinet variations do not have flash sense inputs. The ASC Working Group recommends agencies to ensure flash sense inputs are mapped into the ASC. ASCs that cannot

determine if cabinet flash is active are PROHIBITED from providing any SPaT data to the RSU. See Section [F.3.3.4.3](#) for additional notes about a Failure Flash Indication.

3.5.4.1.3.7.4 Monitor Preemption Operation Indication

Upon request from a management station, the ASC shall return if the intersection is operating in Active Preemption Control. Preempt Control indicates to the receiver of this information that the controller is actively servicing a preemption request. The TimeChangeDetails are generated under assumption that any inactive preemption, NTCIP 1211, or SRM requests remain inactive and any active priority requests remain active until served.

3.5.4.1.3.7.5 Monitor Priority Operation Indication

Upon request from a management station, the ASC shall return if the intersection is operating in Active Priority Control. Priority Control indicates to the receiver of this information that the controller is actively servicing a priority request and thus, the TimeChangeDetails for the intersection may suddenly change as the controller changes from "normal" operations to servicing a priority request as the controller transitions to serve the movement requested. The TimeChangeDetails are generated under assumption that any inactive priority, NTCIP 1211, or SRM requests remain inactive and any active priority requests remain active until served.

3.5.4.1.3.7.6 Monitor Fixed Time Control Indication

Upon request from a management station, the ASC shall return if the intersection is operating under fixed time control. Fixed Time Operation indicates to the receiver of this information that the controller is operating in fixed time and thus the values in TimeChangeDetails are not dynamically changing cycle by cycle.

3.5.4.1.3.7.7 Monitor Non-Fixed Time Control Indication

Upon request from a management station, the ASC shall return if the intersection is operating under Active Demand. Active Demand, also called traffic dependent operation indicates to the receiver of this information that the controller is operating based on different levels of traffic parameters (requests, duration of gaps or more complex parameters), and not a fixed time mode.

The TimeChangeDetails are generated under assumption of any active demand for phase or pedestrian service. This demand can be sourced from cabinet inputs, central system commands, controller configuration, internal logic, or various other means. The TimeChangeDetails are generated upon current demand (Phase/Pedestrian calls) and updated within one second upon changes to this demand.

NOTE: Demand need not be actively serviceable to be considered in the SPaT message. For example, a coordinator may omit a phase until its permissive window opens, however SPaT is to consider this phase to have serviceable demand with expectation of future opening of this permissive window.

3.5.4.1.3.7.8 Monitor Standby Operation Indication

Upon request from a management station, the ASC shall return if the intersection is operating in a soft flash operation (flash through phase loadswitch), and the end of the flash condition is determinate at some point by the controller. StandbyOperation indicates that the controller is in a flashing condition but the controller will be aware of when the controller will exit the flashing condition. Standby operations include startup flash, automatic flash, and preempt flash. See Section [F.3.3.4.8](#) for additional notes about a Standby Operation Indication.

3.5.4.1.3.7.9 Monitor Controller Failure

Upon request from a management station, the ASC shall return if the intersection is in a failure mode. Failure Mode indicates to the receiver of this information that the controller is not operating properly or has failed. Examples of a controller failure mode includes a process in the controller that is not be operating properly, a memory data error was detected, or an internal voltage failure was detected. Most failures will be fatal and would not result in this bit being SET, but for non-catastrophic failures, this bit can be set and the controller would likely activate cabinet flash.

3.5.4.1.3.7.10 Monitor MAP Message Validity

Upon request from a management station, the ASC shall return if the controller is indicating that the MAP message for this intersection should be marked as valid or invalid. The controller may allow an authorized user to indicate that the MAP message for the intersection is invalid because the signalized intersection is under test, or because there is temporary work at the signalized intersection, such as lane closures, that may make the MAP message invalid.

3.5.4.1.3.7.11 Monitor SPaT Data Validity

Upon request from a management station, the ASC shall return if the controller is providing valid or invalid SPaT data for the intersection. The controller may be providing invalid SPaT data that is not to be used if the signalized intersection is under test, or if there is temporary work at the signalized intersection, such as lane closures, that may make the SPaT data invalid.

3.5.4.1.3.8 Mark SPaT Invalid - Controller

Upon request from a management station, the ASC shall store an indication if the SPaT data being provided by the controller is valid or not, i.e., whether the SPaT data to be used or not. Situations when the SPaT data may be invalid include when the signalized intersection is under test, or if there is temporary construction at the signalized intersection such that the SPaT data should be ignored.

3.5.4.1.3.9 Mark SPaT Invalid - Port

Upon request from a management station, the ASC shall store an indication if the SPaT data being provided by the controller to a specific RSU port is valid or not, i.e., whether the SPaT data to be used or not. Situations when the SPaT data may be invalid include when the signalized intersection is under test. Unlike 3.5.4.1.3.8, Mark SPaT Invalid - Controller, this requirement allows the SPaT data to be marked invalid for a specific CV Application Process (e.g., RSU).

3.5.4.1.3.10 Mark MAP Message Invalid - Controller

Upon request from a management station, the ASC shall store an indication if the MAP message associated with the signalized intersection controlled by the controller is valid or not, i.e., whether the MAP message to be used or not. Situations when the MAP message may be invalid include when the signalized intersection is under test, or if there is temporary construction at the signalized intersection such that the MAP message should be ignored.

The MAP message is generally broadcasted by the CV Application Process but the indication on whether a MAP message is valid is contained in the SPaT message and the controller is the primary source of the data for the SPaT message. From a field maintenance perspective, the field maintenance personnel generally have easier access to the traffic controller than the RSU, and are likely to indicate the SPaT data is valid or invalid also. Thus, this requirement allows the field maintenance personnel to indicate whether the SPaT and MAP messages as valid or invalid from the same device (the controller).

3.5.4.1.3.11 Mark MAP Message Invalid - Port

Upon request from a management station, the ASC shall store an indication if the MAP message broadcasted by a specific CV Application Process data is valid or invalid, i.e., whether the MAP message is to be used or not. Situations when the MAP message may be invalid include when the signalized intersection is under test. Unlike 3.5.4.1.3.10, Mark MAP Message Invalid - Controller, this requirement allows the MAP message to be marked invalid for a specific CV Application Process (e.g., RSU).

3.5.4.1.3.12 Manage Signal Group Requirements

The following requirements are for managing signal groups for use in connected intersections. The signalGroupID is used in SAE J2735 to associate every active movement in a given intersection to a designated collection of one or more lanes of a common type (defined in a MAP message).

3.5.4.1.3.12.1 Determine Maximum Number of Signal Groups

Upon request from a management station, the ASC shall return the maximum number of signal groups that can be configured by the ASC.

3.5.4.1.3.12.2 Configure Signal Group Intersection Mapping

Upon request from a management station, the ASC shall store the signal groups and intersection identifiers in use for the intersection.

3.5.4.1.3.12.3 Configure Signal Group Control Source

Upon request from a management station, the ASC shall store the phase or overlap that controls the signal group.

3.5.4.1.3.12.4 Configure Signal Group Indication Types

Upon request from a management station, the ASC shall store the type of Green and Red movements to be indicated for the signal group in a SPaT message. Valid values for Green indication types are preMovement, permissiveMovementAllowed, protectedMovementAllowed, and protected-or-permissive. Valid values for Red types are stopThenProceed, and stopAndRemain.

3.5.4.1.3.12.5 Configure Signal Group Permissive Control Source

Upon request from a management station, the ASC shall store the phase or overlap that determines if the signal group indication is a protected or permissive movement. If the green type for the signal group is not protected-or-permissive, then this requirement is ignored.

3.5.4.1.3.12.6 Configure Signal Group Lanes

Upon request from a management station, the ASC shall store the set of revocable lane(s) that activates a signal group when the set of revocable lane(s) is enabled and deactivates a signal group when revoked. The set of revocable lanes is defined in Section 3.5.4.1.3.4.1, Configure Concurrent Enabled Lanes. If the signal group is enabled, then the movement state for the signal group is included in the SPaT data provided to a CV Application Process.

3.5.4.1.3.12.7 Determine Maximum Number of Signal State Entries

Upon request from a management station, the ASC shall return the number of signal state entries supported by the ASC.

3.5.4.1.3.12.8 Configure Signal State Parameters

Upon request from a management station, the ASC shall store parameters to determine what signal state as defined by DE_MovementPhaseState in SAE J2725 shall be indicated in a SPaT message.

3.5.4.1.4 Manage Assured Green Period Requirements

The requirements for an ASC to support an Assured Green Period in a Connected Vehicle Environment follow.

3.5.4.1.4.1 Configure Assured Green Period

Upon request from a management station, the ASC shall store an AGP for a through vehicle movement at an intersection. The AGP can be calculated according to Section 4.3.2.3 of CTI 4501. A value of 0 indicates that AGP is not in use.

While in Manual Mode, the ASC will not allow a green indication to be terminated before the AGP has been satisfied if the AGP is in use (i.e., if a connected vehicle is within the RLVW detection zone (RDZ)). The ASC will extend a green indication beyond its configured Phase Maximum parameters to accommodate an Assured Green Period (AGP).

The ASC will extend a green indication to accommodate an AGP before accommodating any requests for signal priority. The AGP shall supersede any new or previously granted requests for signal priority at an intersection.

3.5.4.1.4.2 Configure RLVW Detection Zone Detector Input

Upon request from a management station, the ASC shall store the detector input which reports if a connected vehicle is within the RLVW detection zone (RDZ) of a vehicle through movement at an intersection. This requirement allows the ASC to determine if an AGP is needed for that through movement when calculating the minimum end time for the end of a green indication.

3.5.4.1.4.3 Monitor Assured Green End Time

Upon request from a management station, the ASC shall return the Assured Green End Time (AGET) for a movement. The AGET is the Minimum End Time for the movement that is greater than or equal to the current minimum end time plus the AGP when an OBU is detected in an RDZ.

If no connected vehicle is detected within the RLVW detection zone, then the AGP may not be needed, thus the current minimum end time does not need to add the AGP.

The detector input may be a virtual detector based on the RSU processing Basic Safety Messages received by the RSU.

3.5.4.2 ASC – CV Application Process Interface Requirements

The second interface for managing an ASC in a connected vehicle environment is between the ASC Process (ASC) and the CV Application Process.

These requirements allow the ASC to deliver signal phase and timing data to the CV Application Process. From an SNMP standpoint, the ASC is the SNMP manager, and the CV Application Process is the agent.

The sub-requirements to manage the data exchanges between the ASC Process and the CV Application Process are:

- a) Exchange Current and Next Movement Information Requirements

- b) Exchange Next Occurrence of a Movement Requirements
- c) Exchange Presence of Connected Devices Requirements
- d) Exchange Roadway Geometrics Information Requirements

The requirements to manage the data exchanges between an ASC and a CV Application Process follow.

3.5.4.2.1 Exchange Current and Next Movement Information Requirements

The following requirements allow an ASC to exchange current and next movement data with a CV Application Process. The CV Application Process can then use this data to generate SPaT messages, as defined by SAE J2735, to connected devices in the vicinity of the RSU.

3.5.4.2.1.1 Provide Current and Next Movement Information Requirements

The SPaT message that is broadcasted by an RSU to connected vehicles includes information about what vehicle (or pedestrian) movements are permitted and when at a signalized intersection. To provide this information the CV Application Process needs movement data from the ASC. The requirements for an ASC to provide current and next movement information to a CV Application Process are as follows.

There are two options addressed in the following requirements.

- a) The CV Application Process is physically part of the ASC (Physical Architecture 1), and thus the ASC provides data in the form of UPER-encoded SAE J2735 messages.
- b) The ASC is providing SPaT data in a data format to be defined because the CV Application Process will then generate the UPER-encoded SAE J2735 messages.

3.5.4.2.1.1.1 Provide UPER-encoded SPaT Message

Upon request from an ASC, a CV Application Process shall store the UPER-encoded SPaT Message as defined in SAE J2735. The SPaT message contains the following information:

- Timestamp
- Intersection Status
- Enabled Lanes
- For each Signal Group (both current followed by the next movement):
 - Movement State
 - Minimum End Time
 - Maximum End Time
 - NextTime
 - StartTime

This requirement applies only for ASCs where the CV Application Process is physically part of the ASC (Physical Architecture 1).

3.5.4.2.1.1.2 Provide Movement Time Point

Upon request from an ASC, a CV Application Process shall store the time point reference that the ASC will report movement start/end times. Time points are in ticks, each tick representing units of tenths of a second, with a value of 0 representing the top of the hour, resulting in a range of 0 to 35999, and a range of 36000 to 36009 during leap seconds. These time points do not need to be synchronized with UTC time or the RSU time.

This time point is not used in the SAE J2735 SPaT message. The CV Application Process (or RSU) will convert these time points to UTC time to generate the SPaT message.

3.5.4.2.1.1.3 Provide Movement State

Upon request from an ASC, a CV Application Process shall store the overall current state of a movement (for a signal group) at the intersection. The valid states are defined by DE_MovementPhaseState in SAE J2735. If the movement state is not known with a high level of confidence, a value of unavailable is used.

3.5.4.2.1.1.4 Provide Movement Minimum End Time

Upon request from an ASC, a CV Application Process shall store the time point of the earliest possible end of the current movement state (e.g., at the end of a permissive green or at the end of a permissive yellow) of a movement at an intersection, as defined by DE_Timemark in SAE J2735. If the duration of the current state is fixed, this value indicates the end time. This value can be viewed as the earliest possible time point at which the current interval could end, except when unpredictable events relating to a preemption or priority call come into play and disrupt a currently active timing plan. The time point is measured in tenths of a second in the current or next hour.

3.5.4.2.1.1.5 Provide Movement Maximum End Time

Upon request from an ASC, a CV Application Process shall store the time point of the latest possible end of the current movement state (e.g., at the end of a protected green or end of a steady red) of a movement at an intersection, as defined by DE_Timemark in SAE J2735. This value can be viewed as the latest possible time point at which the current interval could end, except when unpredictable events relating to a preemption or priority call come into play and disrupt a currently active timing plan. The time point is measured in tenths of a second in the current or next hour.

If the ASC can calculate the maximum end time, then the ASC is to provide that time point, otherwise, the ASC is to provide a value of unknown.

3.5.4.2.1.1.6 Provide Movement Likely End Time

Upon request from an ASC, a CV Application Process shall store the time point when the current movement state will most likely end (e.g., at the end of a protected green or end of a steady red) at an intersection, as defined by DE_Timemark in SAE J2735. The likely end time point may be predicted based on data available to the ASC. The time point is measured in tenths of a second in the current or next hour.

3.5.4.2.1.1.7 Provide Movement Likely End Time Confidence

Upon request from an ASC, a CV Application Process shall store the statistical confidence that the reported likely end time point of the current movement (e.g., at the end of a protected green or end of a permissive clearance time) at an intersection is accurate. The confidence value is measured as a probability class, as defined by DE_TimeIntervalConfidence in SAE J2735.

3.5.4.2.1.1.8 Provide Next Movement State

Upon request from an ASC, a CV Application Process shall store the movement state immediately after the current movement state (for a signal group) at the intersection. The valid states are defined by DE_MovementPhaseState in SAE J2735. If the next movement state is not known with a high level of confidence, a value of unavailable is used.

3.5.4.2.1.1.9 Provide Next Movement Minimum End Time

Upon request from an ASC, a CV Application Process shall store the time point of the earliest possible end of the movement state immediately after the current movement state at the intersection, as defined by DE_Timemark in SAE J2735. If the duration of the next movement state is fixed, this value indicates the end time point. This value can be viewed as the earliest possible time point at which the next interval

could end, except when unpredictable events relating to a preemption or priority call come into play and disrupt a currently active timing plan. The time point is measured in tenths of a second in the current or next hour. If the next movement state is unknown, the time point of the earliest possible end time is also unknown.

3.5.4.2.1.1.10 Provide Next Movement Maximum End Time

Upon request from an ASC, a CV Application Process shall store the time point of the latest possible end of the movement state immediately after the current movement state at the intersection, as defined by DE_Timemark in SAE J2735. This value can be viewed as the latest possible time point at which the next movement state could end, except when unpredictable events relating to a preemption or priority call come into play and disrupt a currently active timing plan. The time point is measured in tenths of a second in the current or next hour. If the next movement state is unknown, the time point of the latest possible end time is also unknown.

When the interval duration of the next movement state is fixed, such as when the ASC is operating in fixed time or the yellow interval duration, the minimum end time will equal the maximum end time.

3.5.4.2.1.1.11 Provide Next Movement Start Time

Upon request from an ASC, a CV Application Process shall store the time point when the next movement state immediately after the current movement state at the intersection will start, as defined by DE_Timemark in SAE J2735. If the next movement state is unknown, the time point of the next movement start time is also unknown. If the start time is unknown, a value of unknown is used. If the next movement state is unknown, the start time will also be unknown. If the next movement state is known, the start time is equal to the movement minimum end time of the current interval.

Note: Start time is always a future time (See CTI 4501, Section 3.3.3.3.5.6 and 3.3.3.3.5.7). Thus, the start time of the current interval is NOT provided.

3.5.4.2.1.2 Provide Movement Assistance Requirements

The SPaT message in SAE J2735 can also provide potential pedestrian or bicyclist conflicts and queuing information to travelers. The requirements for an ASC to provide this data to an RSU so it can broadcast this information to travelers wishing to traverse through the intersection are defined as follows.

3.5.4.2.1.2.1 Provide Lane Connection Queue Length

Upon request from an ASC, a CV Application Process shall store the distance, in meters, from the stop line of the approach movement to the back edge of the last vehicle in the queue, as measured along the center line of the lane, for a specific movement through the intersection. Valid values are 0 to 10000 meters, where 0 indicates no queue or the queue distance is unknown, and 10000 represents all distance \geq 10000 meters.

3.5.4.2.1.2.2 Provide Lane Connection Traveler Detection

Upon request from an ASC, a CV Application Process shall store if any conflicting pedestrians or bicycles are detected for a specific movement through the intersection. This value is either on or off, with off indicating a high certainty that there is no pedestrian or bicycle present.

3.5.4.2.1.3 Provide Advisory Speed Requirements

The SPaT message in SAE J2735 can also provide speed advisories for specific movements and specific vehicle types. The requirements for an ASC to provide a CV Application Process with advisory speed information for a movement through the intersection are defined as follows.

3.5.4.2.1.3.1 Provide Advisory Speed Type

Upon request from an ASC, a CV Application Process shall store the speed advisory type for a specific movement traversing the intersection. Valid types of speed advisories are defined by DE_AdvisorySpeedType in SAE J2735. Speed advisories may be configured for specific vehicle types as defined in the MAP message for the same intersection.

3.5.4.2.1.3.2 Provide Advisory Speed

Upon request from an ASC, a CV Application Process shall store the advisory speed, in tenths of a meter per second, provided for a specific movement traversing the intersection. Speed advisories may be configured for specific speed advisory types (See 3.5.4.2.1.3.2) or vehicle types as defined in the MAP message for the intersection.

3.5.4.2.1.3.3 Provide Advisory Speed Zone

Upon request from an ASC, a CV Application Process shall store the distance, in meters, upstream from the stop bar that a speed advisory is recommended for a movement traversing the intersection. A value of 10000 indicates that the distance is 10,000 meters or greater.

3.5.4.2.1.3.4 Provide Advisory Speed Vehicle Type

For a specific movement traversing the intersection, upon request from an ASC, a CV Application Process shall store the vehicle type that a speed advisory is intended for. The vehicle type(s) is identified in the MAP message for the intersection. If no vehicle type is identified, then the advisory speed applies to all vehicles.

3.5.4.2.1.4 Provide Road Authority ID

Upon request from an ASC, a CV Application Process shall store the Road Authority ID for an intersection. The Road Authority ID is a unique identifier of the agency that operates and/or maintains the intersection or the ASC. The unique identifier in the US is an object identifier consisting of the Geographic Names Information System (GNIS) codes maintained by the US Geological Survey (USGS). The Road Authority ID is defined by DF_RoadAuthorityID in SAE J2735.

3.5.4.2.1.5 Provide Signal Phase and Timing Intersection Status

Upon request from an ASC, a CV Application Process shall store the status of the ASC as part of the signal phase and timing data. The intersection status values are defined by DE_IntersectionStatusObject in SAE J2735.

3.5.4.2.1.6 Provide SPaT Information to a CV Application Process

Upon request from an ASC, a CV Application Process shall store the mandatory SPaT information needed to generate a J2735 SPaT message. This data is provided by the ASC in a compressed manner so that the data can be transmitted more efficiently. The connected vehicle environment is expected to have limitations in the data rates and data capacity. This requirement allows the ASC to group sets of data so that the data can be transmitted more efficiently.

3.5.4.2.2 Exchange Next Occurrence of a Movement Requirements

The requirements for an ASC to provide information when a movement at an intersection will next be permitted (allowed to move again) follows.

3.5.4.2.2.1 Provide Movement Next Occurrence

Upon request from an ASC, a CV Application Process shall store the estimated time point when the current movement at an intersection is next allowed to proceed (i.e., the movement phase state will be permissive-Movement-Allowed or protected-Movement-Allowed), as defined by DE_Timemark in SAE J2735. The time point is measured in tenths of a second in the current or next hour. This requirement is used to support ECO-driving applications. For fixed time and coordinated signals, next time can be estimated by the ASC, subject to unpredictable events such as signal preemptions, or failures such as a watchdog failure or a conflict monitor. If next time cannot be determined, a value of unknown is used.

3.5.4.2.3 Exchange Presence of Connected Device Requirements

The following requirements allow an ASC to exchange the presence of connected devices detected by a CV Application Process in the vicinity of the ASC. The ASC can use this data as calls for actuated movements or as inputs to determine traffic demand at the intersection. The following requirements allow an ASC to exchange the presence of connected devices with a CV Application Process.

There are two options addressed in the following requirements.

- c) The CV Application Process is physically part of the ASC (Physical Architecture 1), and thus the data received is in the form of UPER-encoded SAE J2735 messages.
- d) The ASC is retrieving the presence of connected devices in another data format to be defined because the UPER-encoded SAE J2735 messages have been processed by the CV Application Process.

3.5.4.2.3.1 Retrieve BSMs

Upon request from an ASC, a CV Application Process shall provide the UPER-encoded BSMs received by the RSU. The RSU may filter the BSMs it receives prior to providing the BSMs to the ASC. The ASC processes the BSMs to determine the location of equipped vehicles and their kinematics (velocity, acceleration). The ASC may use this information to support the need to provide an AGP, to manage the signalized intersection safely, and to improve mobility at a signalized intersection. Only the BSMcoreData is provided.

Note: The VehicleEventFlags frame has information of interest, but that frame is only sent when an event flag is set. (See 6.3.1 in J2945/1).

This requirement applies only for ASCs where the CV Application Process is physically part of the ASC (Physical Architecture 1).

3.5.4.2.3.2 Retrieve PSMs

Upon request from an ASC, a CV Application Process shall provide the UPER-encoded PSMs received by the RSU. The RSU may filter the PSMs it receives prior to providing the PSMs to the ASC. The ASC processes the BSMs to determine the location of equipped travelers and their kinematics (velocity). The ASC may use this information to improve the safety of vulnerable road users (VRUs) at a signalized intersection.

This requirement applies only for ASCs where the CV Application Process is physically part of the ASC (Physical Architecture 1).

3.5.4.2.3.3 Retrieve Actuation Report

Upon request from an ASC, a CV Application Process shall provide the actuation report for connected device detectors configured by the CV Application Process. An actuation report indicates the connected

device detectors that are actuated at the time, based on if any BSMs or PSMs are detected within the detection zone and if the BSM or PSM satisfies the configuration criteria.

3.5.4.2.3.4 Retrieve Detection Report

Upon request from an ASC, a CV Application Process shall provide the detection report for connected device detectors configured by the CV Application Process. The processed data that can be provided by in a detection report are volume, average speed, average travel time, queue length, average gap, and platoon length.

3.5.4.2.4 Exchange Roadway Geometrics Information Requirements

A broadcasted MAP data message provides roadway geometry information to connected devices in the vicinity of the RSU. A roadway geometry plan defines what roadway geometry data is being broadcasted and contain the roadway configuration for one or more intersections. The requirements for an ASC and a CV Application Process to exchange the roadway geometry plan currently broadcasted by the RSU are defined in the following.

3.5.4.2.4.1 Retrieve MAP Plan in Effect

Upon request from an ASC, a CV Application Process shall provide the MAP plan currently being broadcasted by the RSU. The ASC may use this information to determine if the signal pattern in effect is compatible with the roadway geometry data broadcasted by the RSU.

3.5.4.2.4.2 Confirm MAP Plan Compatibility

An ASC shall confirm that the MAP plan broadcasted by an RSU is compatible with the SPAT data generated. An ASC generates SPAT data for consumption by travelers, however, this SPAT data has limited value unless it is broadcast in conjunction with roadway geometry data, relating the movement information with a lane. Thus, it is important that the SPAT data broadcasted by an RSU is compatible with the MAP plan also broadcasted by the RSU. If the SPAT data is not compatible with the MAP plan currently broadcasted, the SPAT data should not be broadcasted by the RSU.

3.5.4.3 ASC – ECLA Interface Requirements

In some scenarios, the signal timing is determined by an external device called the ECLA (See Section 2.3.4.c), which sends commands to the ASC to advance the interval at specific times determined by the ECLA. In this environment, the ASC requires the information below so the ASC can generate accurate SPaT data to a CV Application Process so a SPaT message can be broadcasted by an RSU in an CV environment. The requirements for an ASC to receive signal timing durations and movement states from an ECLA follow.

From an SNMP standpoint, the ASC is the SNMP manager, and the ECLA is the agent.

3.5.4.3.1 Retrieve Current Movement State from an ECLA

Upon request from an ASC, an ECLA shall provide the overall current state of a movement (for a signal group) at the intersection. The valid states are defined by DE_MovementPhaseState in SAE J2735. If the movement state is not known with a high level of confidence, a value of unavailable is used.

3.5.4.3.2 Retrieve Current Minimum End Time from an ECLA

Upon request from an ASC, an ECLA shall provide the time point of the earliest possible end of the current movement state (e.g., at the end of a permissive green or at the end of a permissive yellow) of a movement at an intersection, as defined by DE_Timemark in SAE J2735. If the duration of the current state is fixed, this value indicates the end time. This value can be viewed as the earliest possible time

point at which the current interval could end, except when unpredictable events relating to a preemption or priority call come into play and disrupt a currently active timing plan. The time point is measured in tenths of a second in the current or next hour.

3.5.4.3.3 Retrieve Current Maximum End Time from an ECLA

Upon request from an ASC, an ECLA shall provide the time point of the latest possible end of the current movement state (e.g., at the end of a protected green or end of a steady red) of a movement at an intersection, as defined by DE_Timemark in SAE J2735. This value can be viewed as the latest possible time point at which the current interval could end, except when unpredictable events relating to a preemption or priority call come into play and disrupt a currently active timing plan. The time point is measured in tenths of a second in the current or next hour.

If the ECLA can calculate the maximum end time, then the ECLA is to provide that time point, otherwise, the ECLA is to provide a value of unknown.

3.5.4.3.4 Retrieve Current Likely End Time from an ECLA

Upon request from an ASC, an ECLA shall provide the time point when the current movement state will most likely end (e.g., at the end of a protected green or end of a steady red) at an intersection, as defined by DE_Timemark in SAE J2735. The likely end time point may be predicted based on data available to the ASC. The time point is measured in tenths of a second in the current or next hour.

3.5.4.3.5 Retrieve Current Likely End Time Confidence from an ECLA

Upon request from an ASC, a ECLA shall provide the statistical confidence that the reported likely end time point of the current movement (e.g., at the end of a protected green or end of a permissive clearance time) at an intersection is accurate. The confidence value is measured as a probability class, as defined by DE_TimeIntervalConfidence in SAE J2735.

3.5.4.3.6 Retrieve Next Movement State from an ECLA

Upon request from an ASC, an ECLA shall provide the movement state immediately after the current movement state (for a signal group) at the intersection. The valid states are defined by DE_MovementPhaseState in SAE J2735. If the next movement state is not known with a high level of confidence, a value of unavailable is used.

3.5.4.3.7 Retrieve Next Minimum End Time from an ECLA

Upon request from an ASC, an ECLA shall provide the time point of the earliest possible end of the movement state immediately after the current movement state at the intersection, as defined by DE_Timemark in SAE J2735. If the duration of the next movement state is fixed, this value indicates the end time point. This value can be viewed as the earliest possible time point at which the next interval could end, except when unpredictable events relating to a preemption or priority call come into play and disrupt a currently active timing plan. The time point is measured in tenths of a second in the current or next hour. If the next movement state is unknown, the time point of the earliest possible end time is also unknown.

3.5.4.3.8 Retrieve Next Maximum End Time from an ECLA

Upon request from an ASC, an ECLA shall provide the time point of the latest possible end of the movement state immediately after the current movement state at the intersection, as defined by DE_Timemark in SAE J2735. This value can be viewed as the latest possible time point at which the next movement state could end, except when unpredictable events relating to a preemption or priority call come into play and disrupt a currently active timing plan. The time point is measured in tenths of a second

in the current or next hour. If the next movement state is unknown, the time point of the latest possible end time is also unknown.

When the interval duration of the next movement state is fixed, such as when the ECLA is operating in fixed time or the yellow interval duration, the minimum end time will equal the maximum end time.

3.5.4.3.9 Retrieve Next Movement Start Time from an ECLA

Upon request from an ASC, an ECLA shall provide the time point when the next movement state immediately after the current movement state at the intersection will start, as defined by DE_Timemark in SAE J2735. If the next movement state is unknown, the time point of the next movement start time is also unknown. If the start time is unknown, a value of unknown is used. If the next movement state is unknown, the start time will also be unknown. If the next movement state is known, the start time is equal to the movement minimum end time of the current interval.

Note: Start time is always a future time (See CTI 4501, Section 3.3.3.3.5.6 and 3.3.3.3.5.7). Thus, the start time of the current interval is NOT provided.

3.5.5 Backward Compatibility Requirements

Prior versions of NTCIP 1202 use SNMPv1 as its application layer protocol, while NTCIP 1202 v04 uses SNMPv3 as its application layer protocol. A shortcoming of SNMPv1 is its lack of security – thus *NTCIP 9014, Infrastructure Standards Security Assessment (ISSA)*, published in 2021, recommended migrating the NTCIP center-to-field standards from SNMPv1 to SNMPv3. However, an authentication feature in SNMPv3 breaks backward compatibility for every SNMPv1 message exchanged, thus NTCIP 1202 v04 is not backward compatible with previous versions of NTCIP 1202, so this section is not applicable.

3.6 Supplemental Non-communications Requirements

Supplemental requirements for ASC are provided in the following subsections. These requirements do not directly involve communications via the communications interfaces addressed by NTCIP 1202 v04, but, if the supplemental requirement is selected in the PRL, the implementation shall fulfill the stated requirement to claim conformance to NTCIP 1202.

3.6.1 Response Time for Requests

The ASC processes all requests in accordance with all of the rules of the relevant base standards (i.e., NTCIP 1103 v03 and NTCIP 2301), including updating the value in the database and initiating the transmission of the appropriate response (assuming that the ASC has permission to transmit) within the Response Time. If the specification does not indicate the Response Time, the Response Time shall be 25 milliseconds. The Response Time is measured as the time between the receiving of the last byte of the request and the transmission of the first byte of the response.

3.6.2 Atomic Operations

Reports shall be generated based on atomic operations to prevent multiple reports of the same atomic event. The guidelines for timing and atomic operations are found in NTCIP 1103 v03, Section 6.1.1.

3.6.3 Supplemental Requirements for Event Logging

Supplemental requirements for the user-defined triggers follow.

3.6.3.1 Detect Events Related to an Atomic Object

The ASC shall be able to detect events using a comparison object that is set to any atomic object (i.e., any object that is not configured at runtime). *1201 v0405: 3.5.4.2.5*

3.6.3.2 Reporting an Atomic Object

The ASC shall be able to report a log object that is set to any atomic object (i.e., any object that is not configured at runtime). *1201 v0405: 3.5.4.2.8*

NOTE — While called a "log object", the value is either logged or sent in a notification, dependent upon other configuration parameters.

3.6.4 Condition-based Maximum Transmission Start Time

When a user-specified condition-based exception reporting occurs, the ASC shall initiate the transmission of the appropriate report within the Maximum Transmission Start Time. If the agency specification does not indicate the Condition-based Maximum Transmission Start Time, the Condition-based Maximum Transmission Start Time shall be 10 seconds. The Condition-based Maximum Response Start Time is measured as the time between the time the ASC first detects the occurrence of the event to the time the ASC initiates communications with the management station (e.g., handshake).

3.6.5 Signal Phase and Timing Data Performance Requirements

This section defines the performance requirements for the exchange of signal phase and timing data in a connected vehicle environment. The applicable performance requirements depend on the architecture implemented.

3.6.5.1 SPaT Maximum Transmission Start Time

The ASC shall begin initiating the transmission (SET) of all SPaT data object(s) that changed to the CV Application Process no more than the SPaT Maximum Transmission Start Time after the change to the ground truth of a channel (i.e., when the controller changes the command to the load switch). If the agency specification does not indicate the SPaT Maximum Transmission Start Time, the SPaT Maximum Transmission Start Time shall be 10 milliseconds. The data object may be an individual data object definition or a block object definition.

3.6.5.2 Movement Time Point Minimum Transmission Rate

The ASC shall transmit (SET) the time point reference to the CV Application Process no less than the Movement Time Point Minimum Transmission Rate. If the agency specification does not indicate the Movement Time Point Minimum Transmission Rate, the Movement Time Point Minimum Transmission Rate shall be once per 100 milliseconds.

3.6.5.3 SPaT Maximum Transmission Rate

The ASC shall initiate the transmission (SET) of all SPaT data object(s) to the CV Application Process at least once every 100-millisecond interval, +/- 2 milliseconds. The data object(s) may be individual data object definitions or a block object definition. The 100-millisecond interval is equivalent to the tenth of a second processing cycle for the traffic signal controller. Note that the NEMA TS2 allows a tolerance of 2% in the framing.

3.6.5.4 SPaT Time Accuracy

The point in time reported by the controller in the SPaT data shall be within 100 milliseconds of the time the signal indication changes. When the time of change is known, such as the end of a yellow interval, the minEndTime reported by the controller is equal to the maxEndTime reported. That time should be within 100 milliseconds of the actual time of change (as depicted by the change in ground truth at the load switch). For example, if the time of change occurs 1 ms after midnight, the SPaT can report time of change as midnight or 100 milliseconds after midnight.

§